

ENGLISH

STAR3



Energy & Harmonics Analyser

USER MANUAL

WARNING – Elcontrol Energy Net S.p.a. declines all liability for any damage to people or property caused by unsuitable or incorrect use of its products. Elcontrol Energy Net reserves the right to change product specifications without prior notice.

STAR3

The pages of this diagram are available in 3PH-N mode.
 In 3PH, 3PH-GND, 2PH and 1PH some pages will not be available.

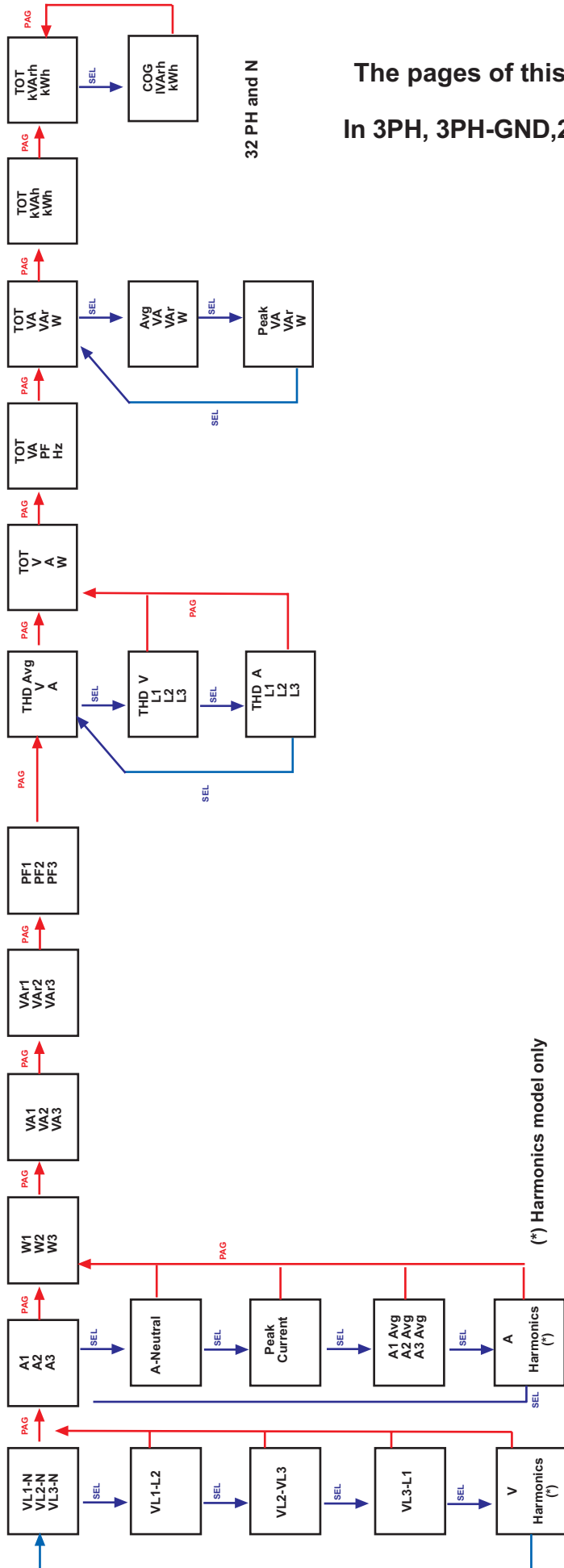

MEASURES PAGES

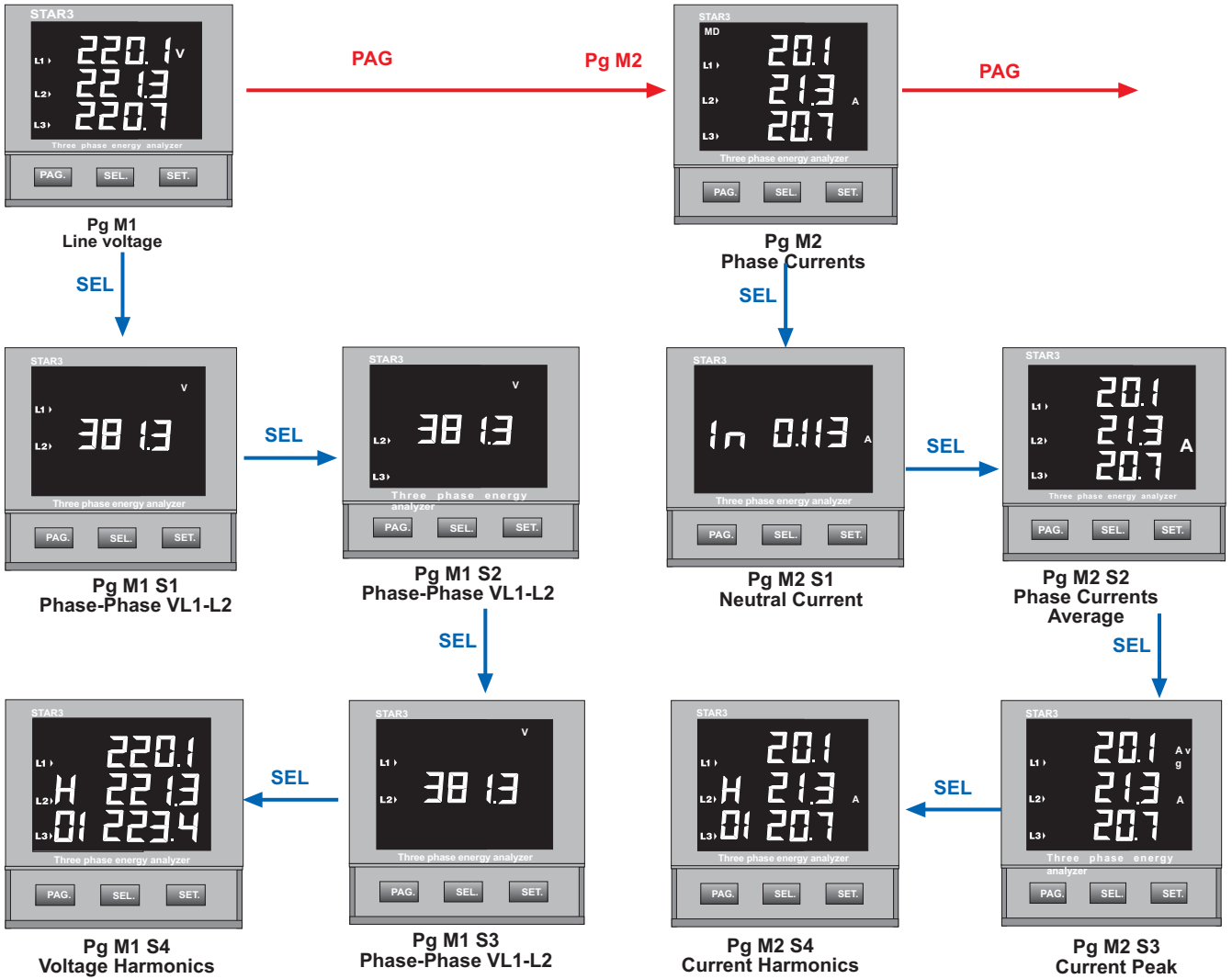

MEASURES PAGES

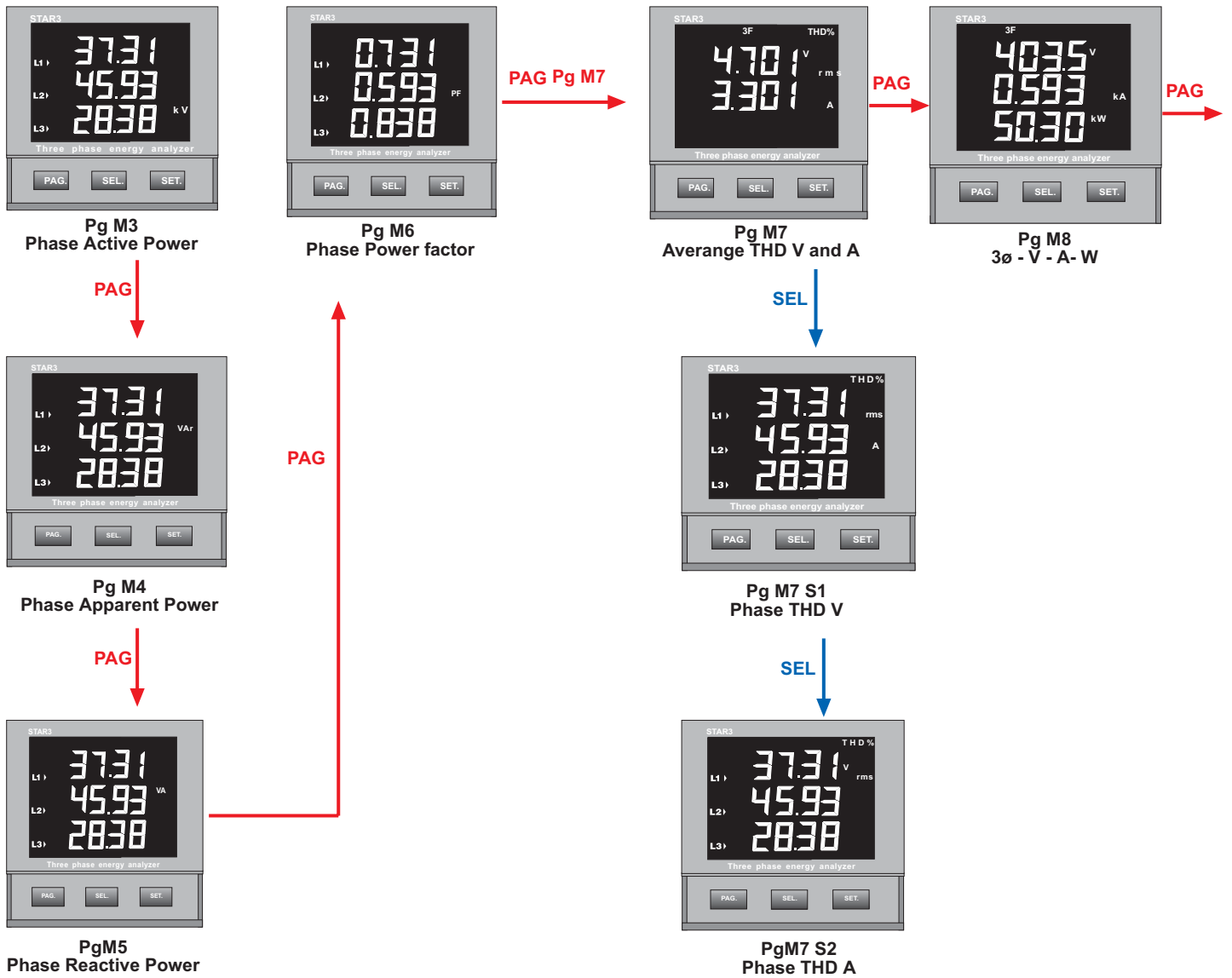

MEASURES PAGES

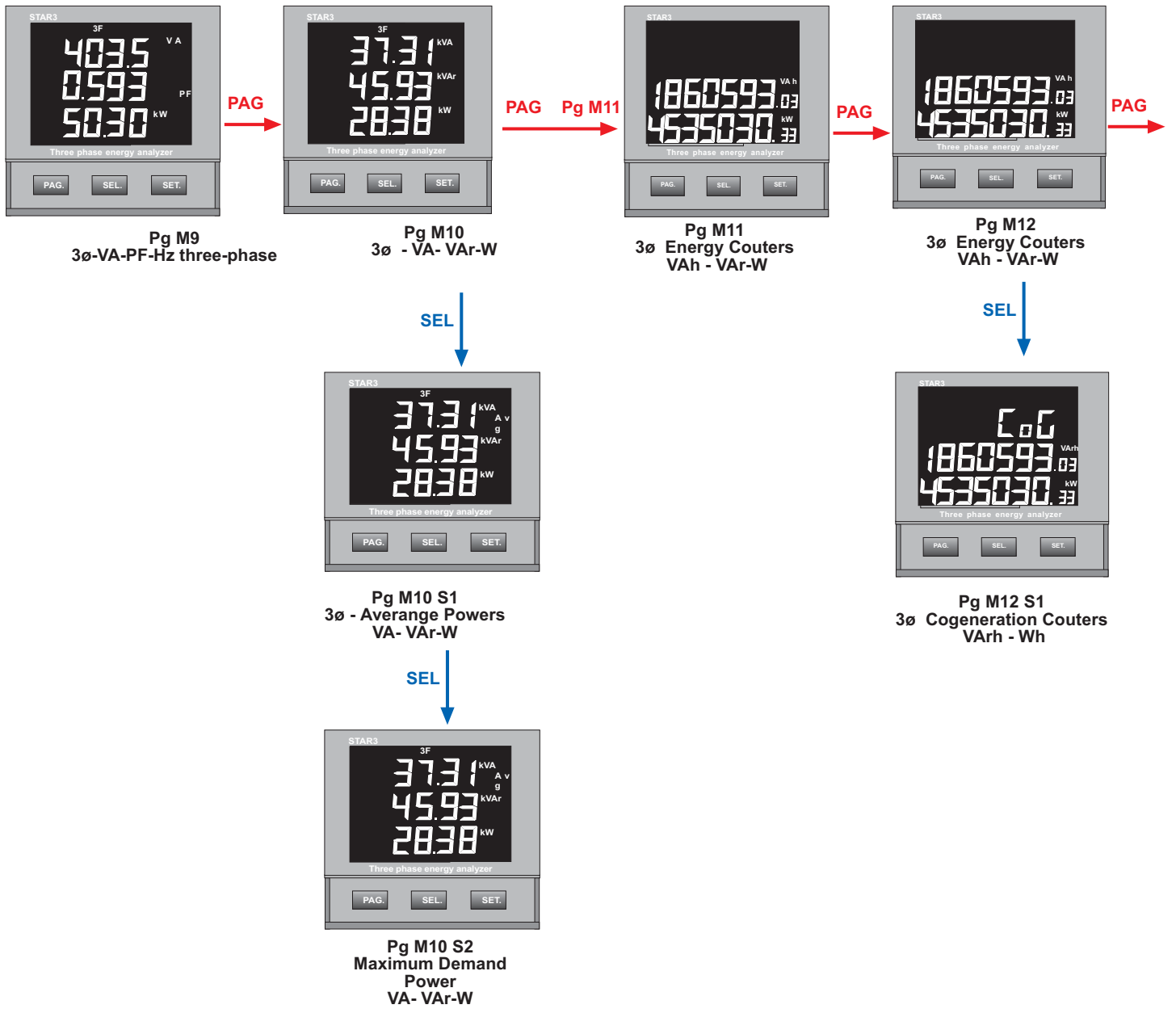

Password setup pages

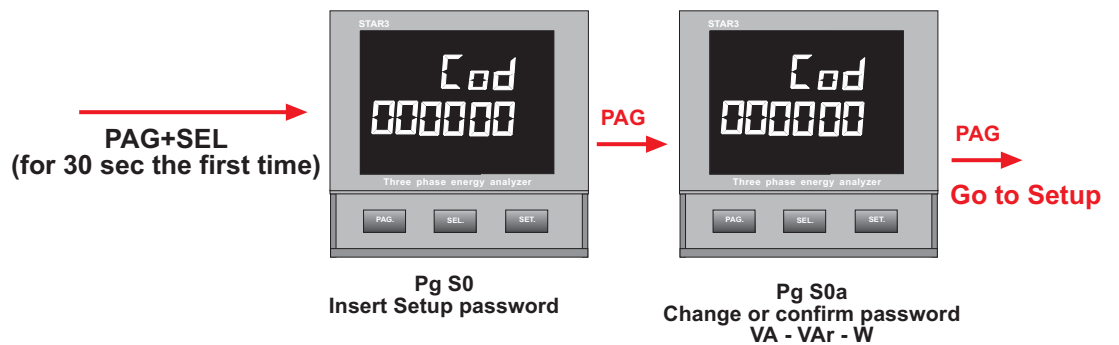

SETUP MENU - ALL MODELS

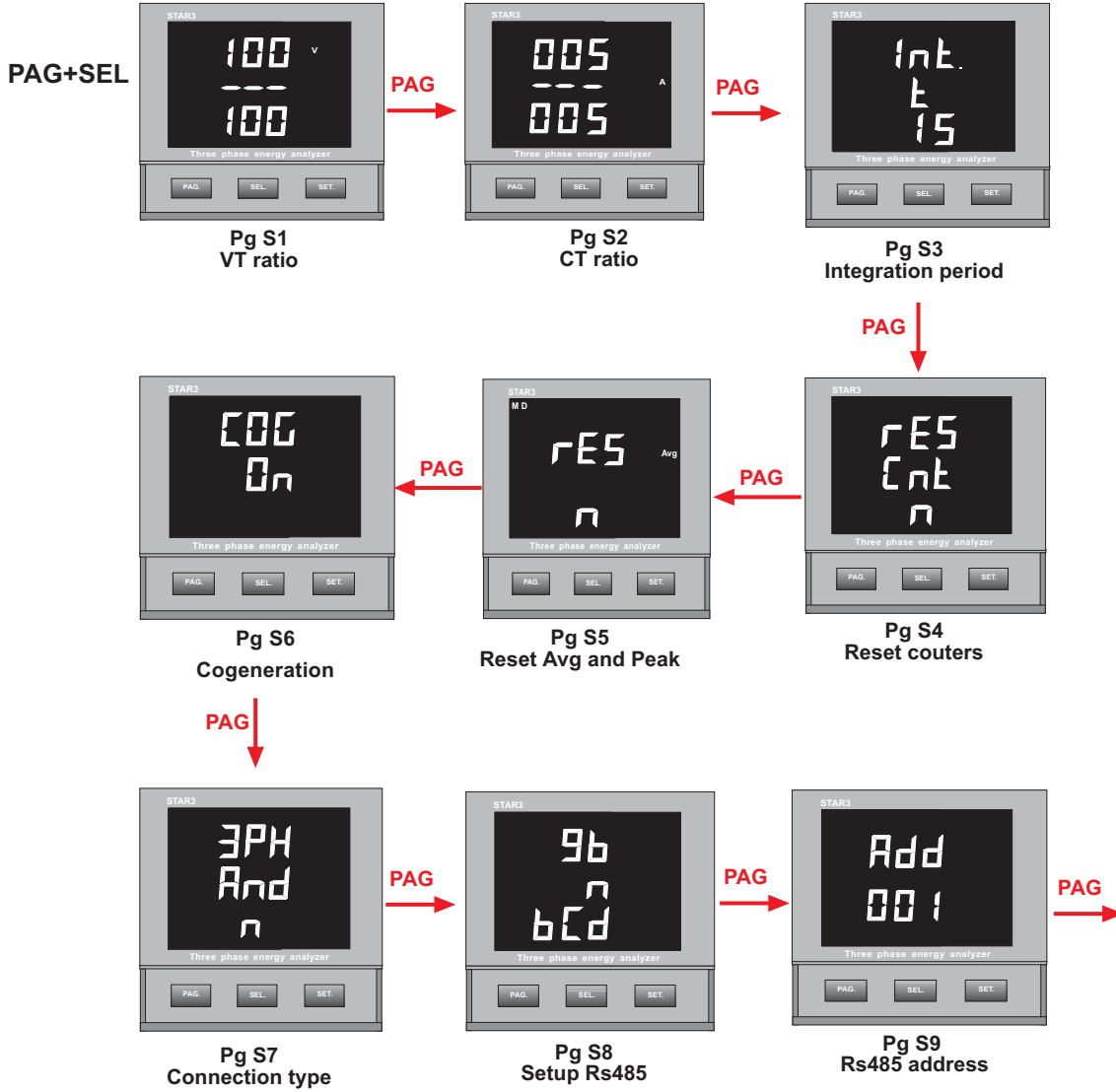

SETUP MENU - ADDITIONAL PAGES FOR MODELS 4-20mA

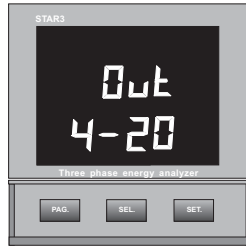

Pg S10 4-20mA
Output range

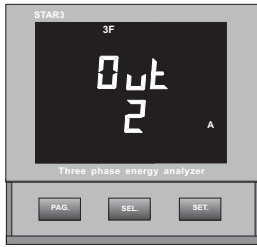

Pg S12 4-20mA
Measure for output 2 selection

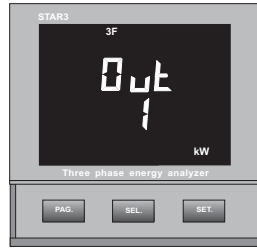

Pg S11 4-20mA
Measure for output 1 selection

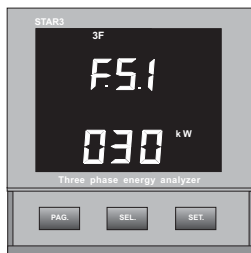

Pg S13 4-20mA
Full scale output 1

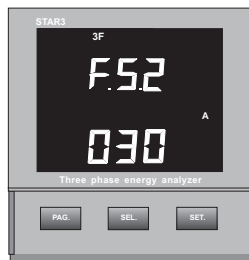

Pg S14 4-20mA
Full scale output 2



SETUP MENU - ADDITIONAL PAGES FOR MODELS ALM AND HARMO

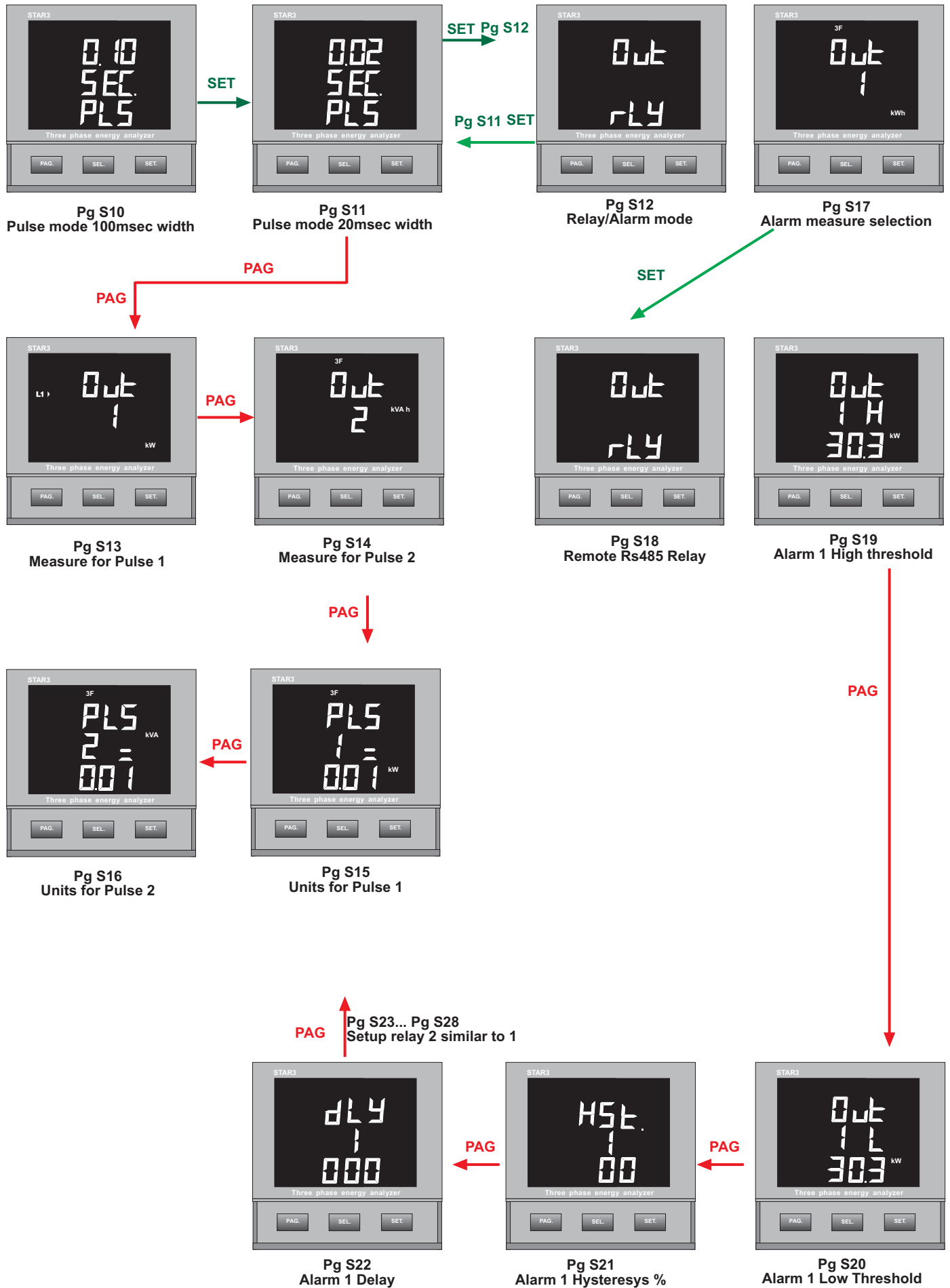

MEASURES CONNECTION DIAGRAMS

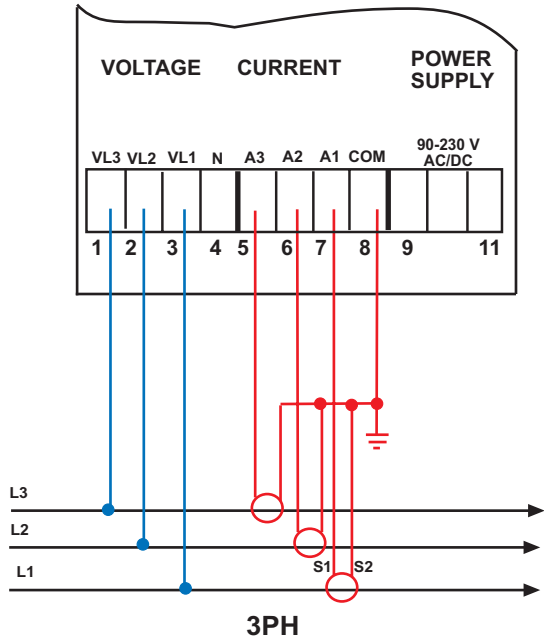

3PH-GND: If phase L1, L2 or L3 is grounded

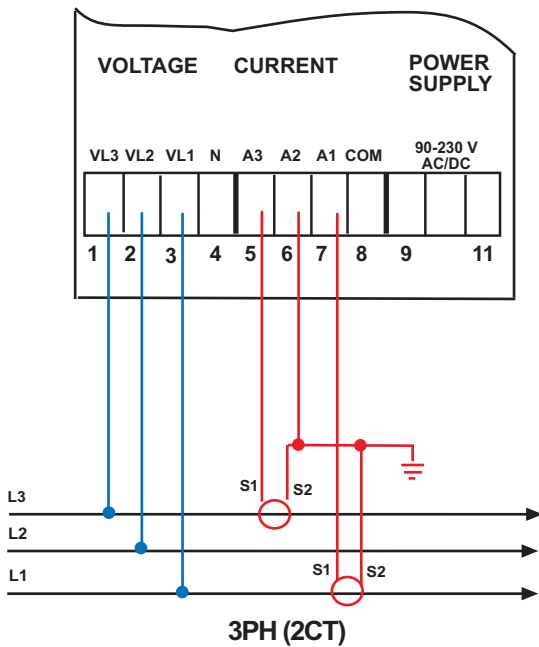
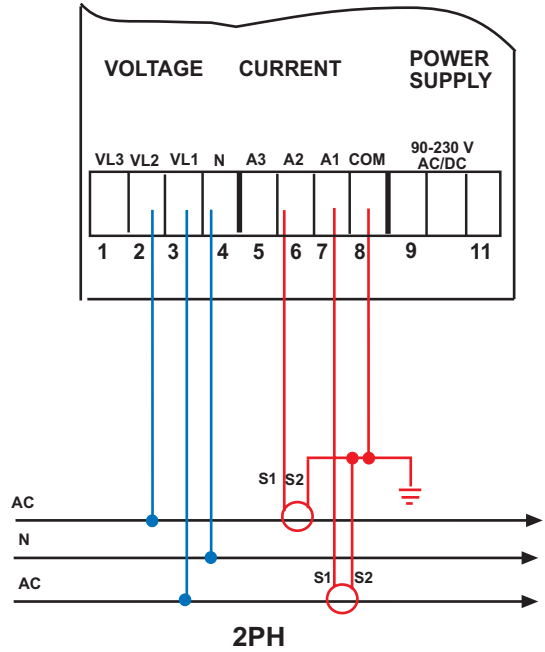

3PH-GND (2CT): If phase L1, L2 or L3 is grounded

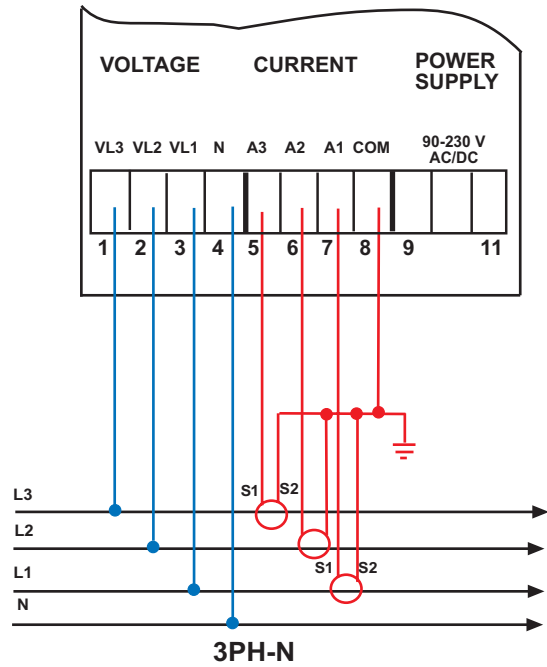

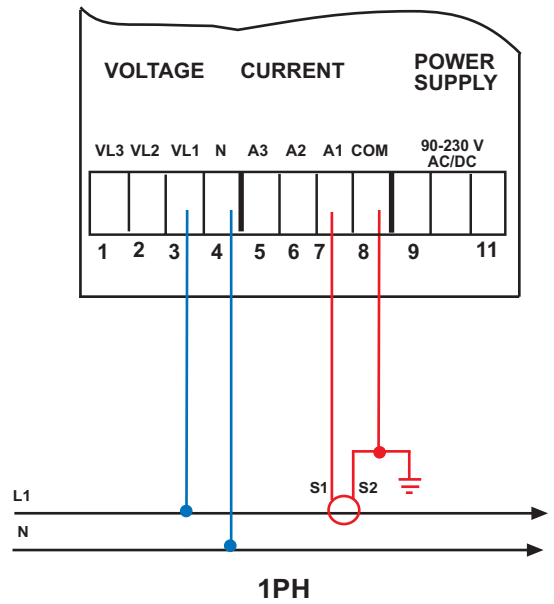
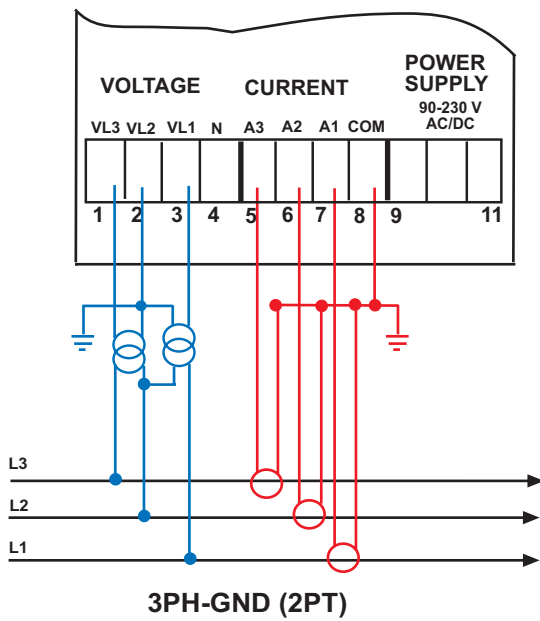

POWER SUPPLY CONNECTION DIAGRAMS

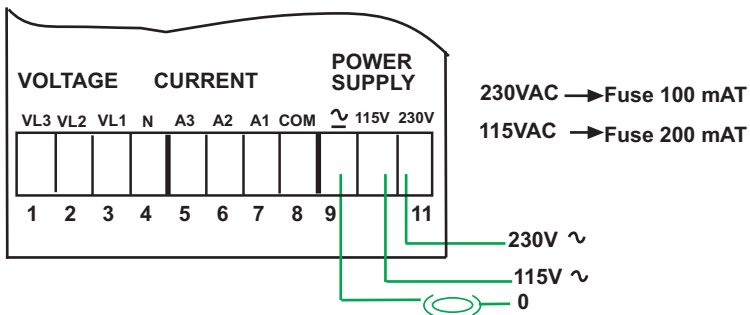

STAR3 models with AC power supply.
Discontinued at the end of 2004

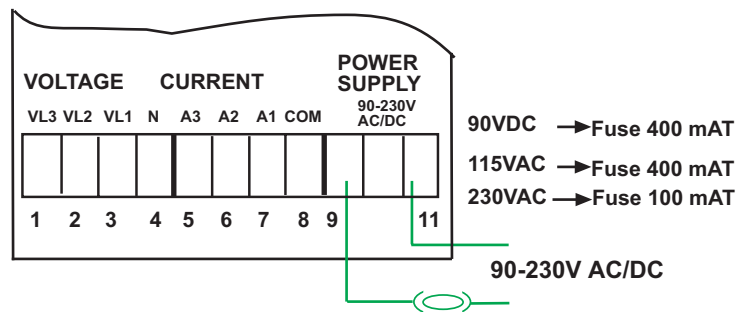

STAR3 with switching power supply

DISPLAYED MEASUREMENT

PARAMETERS	TOT	L1	L2	L3	N
Phase-neutral Voltage [V]	•	•	•	•	
Phase-phase Voltage [V]		L1-L2	L2-L3	L3-L1	
Current [A]	•	•	•	•	•
Power Factor	•	•	•	•	
Frequency [Hz]		•			
Average Current [A]		•	•	•	
Maximum Demand Current [I]	•	•	•	•	
Active Power [kW]	•		•	•	
Reactive Power [kvar]	•	•	•	•	
Apparent Power [kVA]	•	•	•	•	
Average Active Power [kW]	•				
Average Reactive Power [kvar]	•				
Average Apparent Power [kVA]	•				
Maximum Demand Active Power [kW]	•				
Maximum Demand Reactive Power [kvar]	•				
Maximum Demand Apparent Power [kVA]	•				
Positive (Imported) Active Energy [kWh]	•				
COG-negative (Exp.) Active Energy [kWh]	•				
Positive Reactive Energy [kvarh]	•				
COG-negative Reactive Energy [kvarh]	•				
Apparent Energy [kVAh]	•				
Current Thd%	•	•	•	•	
Voltage Thd%	•	•	•	•	

Model HARMO .(1250Hz max: order)

HARMONIC ORDER (k=1..25 @ 50Hz - k=1..20 @ 60Hz)	L1	L2	L3
Harmonic Voltage V _k	•	•	•
Harmonic Current I _k	•	•	•

DIMENSIONS

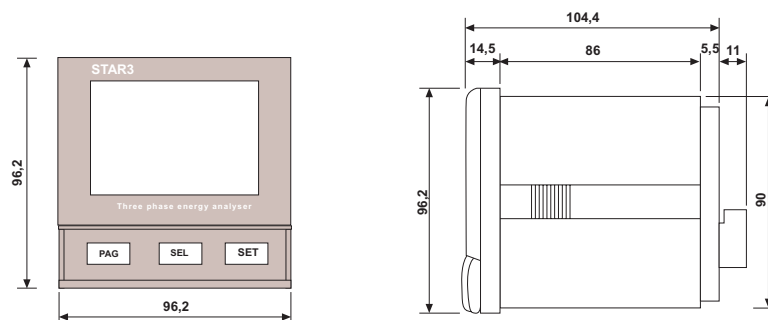

1 - INTRODUCTION

 Please read carefully the instructions with this symbol before installing and using the instrument.

1.1 - STANDARDS and REGULATIONS

STAR3 conforms to Directive 73/23/CEE (LVD) and 2004/108/CE (EMC).

It has been designed with reference to EN 61010-1, EN 61326 including append. A1/A2/A3, EN 61000-6-2, EN 61000-6-3, EN 61000-3-2, EN 61000-3-3, EN 61000-3-3/A1, EN 61000-4-2, EN 61000-4-3, EN 61000-4-4, EN 61000-4-5, EN 61000-4-5/A1, EN 61000-4-6, EN 61000-4-6/A1, EN 61000-4-8, EN 61000-4-8/A1, EN 61000-4-11, EN 61000-4-11/A1.

1.2 - USER SAFETY

In order to preserve these safety conditions and ensure safe operation, the user must observe all instructions and marks specified in this user manual. All maintenance and repair operations requiring the opening of the instrument must be carried out only by suitably qualified and authorised personnel. The instrument was shipped from the manufacturing plant in perfect technical safety conditions.

1.3 - PRELIMINARY INSPECTIONS

Before installation, check that the instrument is in good conditions and was not damaged during transport. Check that the network voltage and the rated voltage coincide. This instrument does not require an earth connection.

1.4 - PRECAUTIONS IN THE EVENTS OF MALFUNCTIONS

When safe operation is no longer possible, put the instrument out of service and ensure that it cannot be operated accidentally. Safe operation cannot be guaranteed in the following circumstances:

- When the instrument appears clearly damaged.
- When the instrument no longer works.
- After long storage in unsuitable conditions.
- After being damaged in transit.

2 - CONNECTION OF THE INSTRUMENT

2.1 - POWER SUPPLY

The power supply connections terminals are located on the rear side and are clearly indicated with the label POWER SUPPLY. Use cables having a maximum section of 2.5 mm². Earth connection is not required. Follow the connection diagram at the beginning of the manual.

2.2 - CONNECTING VOLTAGE MEASUREMENT CABLES

These cables, having a maximum section of 2.5 mm², are to be connected to the terminals labelled VOLTAGE INPUT as indicated in the diagrams at the beginning of the manual.

2.3 - CONNECTING CURRENT MEASUREMENT CABLE

The instrument is able to measure up to 5A only through external C.T. The cables having maximum section of 2.5 mm² must be connected to the terminals labelled CURRENT INPUT as shown in the diagrams at beginning of the manual. Use 3 CT's with 5A secondary. Use cables having a section appropriate to the length of the connection and the rated power of the CT's used.

Note 1: For safety reasons, never leave the CT secondary open.

Note 2: Important direct connections, without C.T. will damage the inputs.

3 - PROGRAMMING THE INSTRUMENT

The instrument can be fully programmed by means of the SETUP menu. Press at the same time the PAG and the SEL keys to enter the SETUP. The complete description of the setup is available at chapter 5.

4 - MEASUREMENT PAGES

At power on, the STAR3 displays the last page selected before power off.

Use the PAG key to scroll through the different measurement pages and the SEL key to see the details.

The presence of several pages is depending on the connection mode selected into the setup .

3PH-N:	Three phases with neutral, i.e. Star , 4 wires system
3PH:	Three phases without neutral, i.e. Delta, 3 wires system
3PH-GND:	Three phases without neutral, one phase connected to ground, 3 wires system
2PH:	Two phases and neutral
1PH:	Single phase

Page M1 (page and subpages not available in 1PH mode)

Phase-neutral voltages	VL1-N, VL2-N, VL3-N	(3PH-N, 3PH)
Phase to phase voltage	VL1-L2, VL2-L3, VL3-L1	(3PH-GND)
Phase-neutral voltages	VL1-N, VL2-N	(2PH)

•**Page M1-S1** (page appearing only in 3PH-N and 2PH)

Phase to Phase Voltage	VL1-L2
------------------------	--------

•**Page M1-S2** (page appearing only in 3PH-N)

Phase to Phase Voltage	VL2-L3
------------------------	--------

•**Page M1-S3** (page appearing only in 3PH-N)

Phase to Phase Voltage	VL3-L1
------------------------	--------

•**Page M1-S4** (page appearing only in STAR HARMO. VL1 has to be connected)

Harmonics Voltages	VL1h, VL2h, VL3h
--------------------	------------------

Use the key SEL to scroll all the harmonics orders h .

The maximum order is depending on the fundamental. It is the 25th at 50 Hz

The voltage input are not connected the harmonics menu does not appear.

•**Page M2** (page and sub pages not available in 1 PH)

Phase currents	AL1, AL2, AL3	(3PH-N, 3PH, 3PH-GND)
Phase currents	AL1, AL2	(2PH)

•**Page M2-S1** (present only in three 3PH-N; 3PH, 3PH-GND)

Neutral current	A _{neutral}
-----------------	----------------------

•**Page M2-S2**

Average Phase currents	AL1 _{Avg} , AL2 _{Avg} , AL3 _{Avg}
------------------------	--

The integration time is the same used for the Average power and it is adjustable into the setup menu.

•**Page M2-S3**

Phase current peaks maximum average currents.	AL1 _{peak} , AL2 _{peak} , AL3 _{peak}
--	---

•**Page M2-S4** (Page appearing only in STAR3 HARMO)

Harmonics Currents	AL1 _h , AL2 _h , AL3 _h
--------------------	--

Use the key SEL to scroll all the harmonics orders h .

The maximum order is depending on the fundamental. It is the 25th at 50 H

•**Page M3** (page not available in 1PH)

Phase active powers (kW)	P _{L1} , P _{L2} , P _{L3}	(3PH-N, 3PH, 3PH-GND)
Phase active powers	P _{L1} , P _{L2}	(2PH)

•**Page M4** (page not available in 1PH)

Phase Apparent powers (kVA)	S _{L1} , S _{L2} , S _{L3}	(3PH-N, 3 PH, 3PH-GND)
Phase apparent powers	S _{L1} , S _{L2}	(2PH)

•**Page M5** (not available in 1PH)

Phase reactive powers (kVar)	Q _{L1} , Q _{L2} , Q _{L3}	(3PH-N, 3PH, 3PH-GND)
Phase reactive powers	Q _{L1} , Q _{L2} ,	(2PH)

•**Page M6** (not available in 1PH)

Phase Power Factor	PF _{L1} , PF _{L2} , PF _{L3}	(3PH-N, 3PH, 3PH-GND)
Phase reactive powers	PF _{L1} , PF _{L2} ,	(2PH)

•**Page M7**

Average Total Harmonic Distortion Factors

Avg THDV= (THDV_{L1}+THDV_{L2}+THDV_{L3})/3;

Avg THDA= (THDA_{L1}+THA_{L2}+THDA_{L3})/3

These special parameters allow to identify immediately if one of the phases is distorted

•**Page M7-S1** (not available in 1PH mode)

Phase THD V	THDV1, THDV2 ; THDV3	(3PH-N, 3PH, 3PH-GND)
	THDV1, THDV2	(2PH)

e.g.: THDV1 =

$$\frac{\sqrt{\sum_{h=2}^{25} V1_h^2}}{V1_{rms}} = \frac{\sqrt{(V1_{rms}^2 - V1_{fnd}^2)}}{V1_{rms}}$$

•**Page M7-S2** (not available in 1PH mode)

Phase THD A	THDA1, THDA2 ; THDA3	(3PH-N, 3PH, 3PH-GND)
	THDA1, THDA2	(2PH)

e.g.: THDA1=

$$\frac{\sqrt{\sum_{h=2}^{25} A1_h^2}}{A1_{rms}} = \frac{\sqrt{(A1_{rms}^2 - A1_{fnd}^2)}}{A1_{rms}}$$

·Page M8

Equivalent three-phase voltage	$V = (V_{L1-N} + V_{L2-N} + V_{L3-N}) / 3$	(3PH-N)
Equivalent three-phase voltage	$V = (V_{L1-L2} + V_{L2-L3} + V_{L3-L1}) / 3$	(3PH, 3PH-GND)
Phase to phase voltage	$V = V_{L1-N} + V_{L2-N}$	(2PH)
Phase-Neutral voltage	$V = V_{L1-N}$	(1PH)
Equivalent. three-phase current	$A = S / (3 V)$ $A = S / V$ $A = A_{L1}$	(3PH-N, 3PH, 3PH-GND) (2PH) (1PH)
Total Active power (kW)	$P = P_{L1} + P_{L2} + P_{L3}$ $P = P_{L1} + P_{L2}$ $P = P_{L1}$	(3PH-N, 3PH, 3PH-GND) (2PH) (1PH)

·Page M9

Total Apparent power (kVA)	$S = (P^2 + Q^2)$
Power factor	P.F. = P / S
Frequency (of V_{L1})	f (Hz)

·Page M10

Apparent power	S= repeated as page M9	
Total Reactive power (kVAr)	$Q = Q_{L1} + Q_{L2} + Q_{L3}$	(3PH-N, 3PH, 3PH-GND)
Total reactive power	$Q = Q_{L1} + Q_{L2}$	(2PH)
Total Active Power	P= repeated as page M8	

·Page M10-S1

1- Average apparent power	S avg
2- Average reactive power	Q avg
3- Average active power	P avg

The integration time can be adjusted into the Setup menu

The average values can be reset into the Setup menu

·Page M10-S2

1-Maximum demand apparent power	S peak
2-Maximum demand reactive power	Q peak
3-Maximum demand active power	P peak

The peaks values can be reset into the Setup menu

·Page M11

Total apparent energy counter	kVAh
Total active energy counter	kWh
range 0,000,000.00-99,999,999.9	kWh.

When the upper limit is reached, the counter restarts from 00,000,000.0 kWh.

One decimal disappear definitively after the first roll-over. Reset the counter to display it again

·Page M12

Total reactive energy counter	kVArh
Total active energy counter	kWh
range 0,000,000.00-99,999,999.9	kWh.

When the upper limit is reached, the counter restarts from 00,000,000.0 kWh.

One decimal disappear definitively after the first roll-over. Reset the counter to display it again

·Page M12-S1

Cogeneration counters. This page is available only if the COG is enabled into the SETUP.

Total capacitive reactive energy	kVArh
Total exported active energy	kWh

To measure properly the cogeneration counters it is strictly necessary to connect the CTs oriented in the same direction. This is not required if the Cogeneration is OFF

5 - SETUP PAGES

To access the SETUP open the front door and press the PAG and the SEL keys at the same time:

Use the SEL key to select a digit or a setting. Use the SET key to adjust it.

The setup can be protected with a password (see next chapter)

·Page S1 Programming the Primary and Secondary ratio of a PT.

Use a ratio equal to 1 (e.g. 100/100) in case of direct measurement without voltage transformer is not used. Select a digit with the SEL key; change its value using the SET key.

·Page S2 Programming the Primary and Secondary Windings of a Current Transformer

Select a digit with the SEL key; change its value with the SET key.

·Page S3 Integration time for Power and current averages, range 00-99min.

Select a digit with the SEL key; change its value with the SET key.

·Page S4 Reset energy counters.

If you select Y with the SET key, all the counters will be reset as soon you confirm by pressing the PAG. key.

·**Page S5** Reset Averages and Maximum Demands, Power and current averages.
 If you select Y with the SET key, all the Averages and maximum demand values will be reset as soon you confirm by pressing the PAG. key.

·**Page S6** Enable Cogeneration counters.
 Select ON or Off to enable the measures and confirm with PAG.
 Cogeneration is always ON if 3PH-GND is selected.
 To measure properly the cogeneration counters it is strictly necessary to connect the CTs oriented in the same direction. This is not required if the Cogeneration is OFF

·**Page S7** Programming connection type
 Select the type of system which you want to measure using the SET key.

·Page S7a	3PH	Three phases without neutral (i.e. Delta)
·Page S7b	3PH-GND	Three phases without neutral, one phase connected to ground
·Page S7c	3PH And n	Three phases with neutral (i.e. Star)
·Page S7d	2PH	Two-phases with neutral
·Page S7e	1PH	Single phase with neutral

·**Page S8** Rs485 communication parameters setup
 Baud Rate: (3 top digits) can have the following values: 2.4, 4.8, 9.6, 19.2 (kbaud)
 The Parity (central) value can be : N(None), O(Odd), E(Even).
 The type of communication protocol Modbus (3 bottom digits) can be:
 ASCII = Modbus ASCII. This format is limited to simulate the same data frame of the Vip Energy.
 BCD = Modbus BCD. It allows the full control of the instrument
 IEEE = Modbus IEEE standard, INTEL format

·**Page S9** Rs485 instrument address
 The Modbus address of the instrument can be set in this page.
 The permitted address field ranges between 1 and 247.

The page S9 is the last one of the basic model STAR3 family.
 Other pages will follow only if the STAR3 is equipped with the options HARMO, ALM, 4-20mA

6 - SET-UP PAGE PROTECTION CODE

By default, the access code to set-up pages is not enabled. To enable it, keep the PAG + SEL keys pressed simultaneously for 30 sec. The display will show the page on which the access code must be entered.

·**Page S0** enter setup password
 By means of the SEL + SET keys, every digit can be changed and the code can be entered. The initial factory code , that must be entered the first time is 000000.
 Confirm and exit from this page by pressing the PAG key.

·**Page S0a** mmodify password
 Now a second page (with "COD" blinking), identical to the first one, is displayed:
 From this page, the access code can be permanently changed, if wished.
 In this case remember or make a safe note of the new code somewhere you can find it later on.
 To exit from the second page press the PAG key.

IMPORTANT: After the first access to the password page, the request of the code will become permanent.
 From that moment on the code must be always entered to access the set-up page.
 Avoid to recall the password page, for test purposes, if the code request is not permanently desired.

SETUP PASSWORD MEMO	
STAR3 SERIAL#	
INSTALLED AT	
FACTORY PASSWORD	000000
DATE	
NEW PASSWORD	
DATE	
NEW PASSWORD	
DATE	
NEW PASSWORD	

7 – ADDITIONAL SETUP PAGES FOR MODELS STAR3 HARMO and ALM

To access Programming Mode, open the front door and press the PAG and the SEL keys at the same time. Use the SEL key to select a digit or a setting. Use the SET key to adjust it.

The setup can be protected with a password (see chapter 6)

•**Page S10** Pulses with length 100 msec

Enable Pulse mode with pulse length of 100 msec

Press PAG to confirm . Press SET for selection, 20 msec (S11). RLY (S12).

•**Page S11** Pulses with length 20 msec

Enable Pulse mode with pulse length of 20 msec .

Press PAG to confirm. Press SET for the next selection (go to S16)

•**Page S12** ALM

The confirmation of this page enable the remote relay control or the alarm mode.

Press PAG to confirm

Press SET to go to the pulse mode (go to S10).

PULSE OUTPUT

•**Page S13** Measure corresponding to output 1 .

Pressing the SET key enables to select the measure corresponding to output 1:

kWh tot

kWh tot COG

kVArh tot

kVArh tot COG

kVAh tot

•**Page S14** Measure corresponding to output 2.

Pressing the SET key enables to select the measure corresponding to output 2.

The measure available are the same of page S12 for output 1.

•**Page S15** Weight of 1 pulse output 1

Number of kWh corresponding to 1 pulse.

E.g.: 1 pulse = 0.01 kWh

Pressing the SEL key to select the digit to modify.

Pressing the SET key to adjust the selected digit to modify.

Pressing the PAG key enables to go to output 2 pulse weight set-up.

•**Page S16** Weight of 1 pulse output 2.

Same as S14 for output 2.

This is the last page of the setup. Press PAG to return to the measure pages

RELAYS or ALARM OUTPUT

•**Page S17** Measure for Alarm 1

Association of the output 1 with a measures for alarm controlling. Press the SET key to choose one the following measures The following list is available in 3PH-N mode.

Some of the measures are not carried out in 1PH, 2PH and 3PH mode and therefore can not be found in the setup of the alarm.

V total ;	VL1;	VL2;	VL3
A total ;	AL1;	AL2;	AL3
kW total ;	kWL1;	kWL2;	kWL3
kVA total ;	kVAL1;	kVAL2;	kVAL3
kVA total;	kVArl1;	kVArl2;	kVArl3
PF total ;	PFL1;	PFL2;	PFL3
THDV tot ;	THDV L1;	THDV L2;	THDV L3
THD A tot ;	THDA L1;	THDA L2;	THDA L3

RLY = relay 1 controlled remotely, via RS485, instead of locally as an alarm (go to S18)

Pressing the PAG key enables to go to one of the following pages:

set-up of the upper threshold of output 1 if one of the measures has been selected; (S19)

set-up of the relay output 2 if the remote mode has been selected for output 1 (S24)

•**Page S18** Remote Rs485 relay 1 control

if RLY is confirmed in S17 (see above) the position of the relay 1 is decided by the Rs485 master device (PC , PLC, etc) Press PAG to accept the RLY selection and enter the setup of relay 2 (go to S23) Press SET to enable the alarm mode (go to S17).

- **Page S19** Alarm 1 High threshold
 Set-up of the upper threshold (H) of the selected measure. When the measure remain above the threshold + hysteresis , for a time longer than the requested delay, the relay 1 is closed, range 000-999 (000-99.9 for the active, reactive and apparent powers) x 10⁶.
 Press the SEL key to select the digit or exponent to be modified.
 Press the SET key to modify the selected digit or exponent.
 Press the PAG key to go to the output 1 lower threshold set-up page.
- **Page S20** Alarm 1 Low threshold
 Set-up of the lower threshold (L) of the selected measure.
 When the measure remain below the threshold hysteresis , for a time longer than the requested delay, the relay 1 is closed, range 000-999 (000-99.9 for the active, reactive and apparent powers) x 10⁶.
 Press the SEL key to select the digit or exponent to be modified.
 Press the SET key to modify the selected digit or exponent.
 Press the PAG key to go to the relay 1 hysteresis set-up page.
- **Page S21** Alarm 1 hysteresys
 A value between 00 and 99 can be set in the 3 bottom digits, expressed as a % (percentage) of the alarm threshold.
 The alarm condition is accepted only if the measure become higher than Threshold*(1+hysteresys%)
 Pressing the SEL key enables to select the digit to modify.
 Pressing the SET key enables to modify the selected digit.
 E.g.: hysteresys = 02%
 Pressing the PAG key enables to go to the relay 1 operation delay time set-up page.
- **Page S22** Alarm 1 Delay
 Relay 1 operation delay time set-up
 A delay figure between 000 and 999 can be set in the 3 bottom digits, expressed in seconds.
 The alarm will toggle only if the new alarm condition persist for a time longer than the delay
 Press the SEL key enables to select the digit to modify.
 Press the SET key enables to modify the selected digit.
 Press the PAG key to go to set-up of the output 2
- **Page S23** Measure for Alarm 2
 Similar to S17 for relay 2.
- **Page S24** Remote RS485 relay 2 control
 Similar to S18 for relay 2.
- **Page S25** Alarm 2 High threshold
 Similar to S19 for relay 2.
- **Page S26** Alarm 2 Low threshold
 Similar to S20 for relay 2.
- **Page S27** Alarm 2 hysteresis
 Similar to S21 for relay 2.
- **Page S28** Alarm 2 Delay
 Similar to S22 for relay 2.

8 – ADDITIONAL SETUP PAGES FOR MODEL STAR3 4-20mA

To access Programming Mode, open the front door and press the PAG and the SEL keys at the same time. Use the SEL key to select a digit or a setting. Use the SET key to adjust it. The setup can be protected with a password (see chapter 6)

- **Page S10** 4-20mA – Analogue output range
 By pressing the SET key, the type of output (either 4-20mA or 0-20mA) can be selected.
 Pressing the PAG key enables to go to the measure selection page corresponding to output 1.
- **Page S11** 4-20mA – Measure for output 1
 Output 1 measure selection
 By pressing the SET key one of the following measures can be selected for output 1:
 V total (3PH, 3PH-GND, 2PH or 1PH according to the instrument set-up)
 A total (3PH, 3PH-GND, 2PH or 1PH according to the instrument set-up)
 Hz
 kW total (3PH, 3 PH-GND, 2 PH or 1 PH according to the instrument set-up)
 kVA total (3PH, 3PH-GND, 2PH or 1PH according to the instrument set-up)
 kVAr total (3PH, 3PH-GND, 2PH or 1PH according to the instrument set-up)
 PF total (3PH, 3PH-GND, 2PH or 1PH according to the instrument set-up)
 Pressing the PAG key enables to go to the measure selection page corresponding to output 2.

•Page S12 4-20mA – Measure for output 2

Similar to the previous page for output 1
Press PAG to go to the output 1 end value set-up page.

•Page S13 4-20mA Output 1 full scale value set-up

Press the SEL key to select the exponent or the digit to modify.
Press the SET key to modify the selected exponent or digit.
Press the PAG key to go to the output 2 end value set-up page.

•Page S14 4-20mA - Output 2 full scale value set-up

The programming procedure is the same as the output 1 full scale value.
The PAG key enables to return to the measurement page.

9 - ELECTRICAL SPECIFICATIONS OF THE OPTIONAL OUTPUTS

SERIAL OUTPUT 485

Standard Rs485, max 32 instruments on each line without repeater, up to 247 instruments with repeaters

ANALOG OUTPUTS 4-20mA

Max load impedance 500 (output conversion from 0-20 mA to 0-10 V with 500 output impedance)
The output signal accuracy is the same as the correlative measure 10 A.
The output update time is 1 second.

RELAY OUTPUTS

Max load 250 VAC rms - 100mA rms

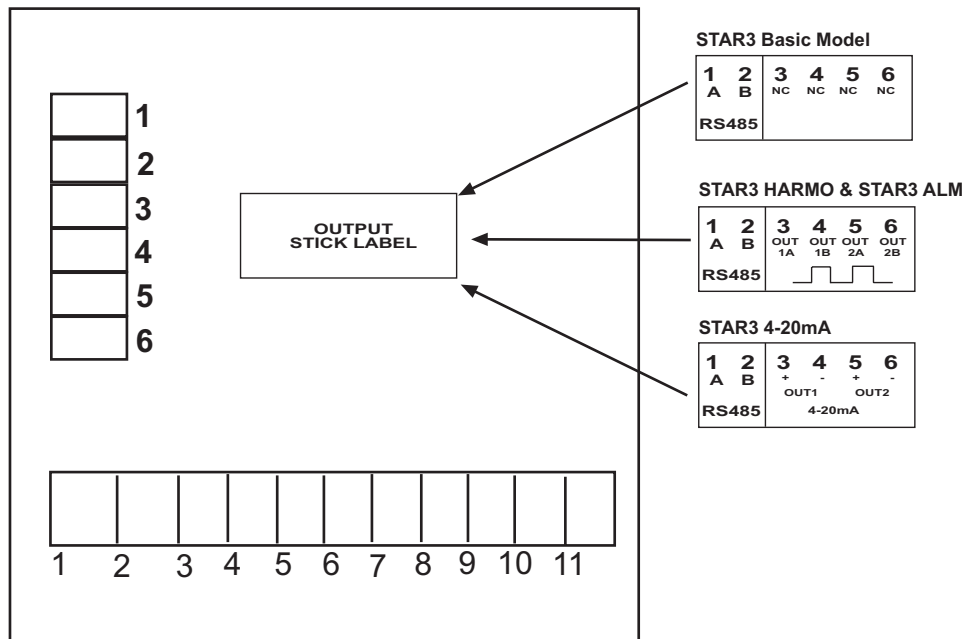

10 - TECHNICAL CHARACTERISTICS

Maximum dimensions (mm): instrument: 157,5 x 58 x 90

Power supply:

- Until end 2004: 230Vac or 115 Vac +15%-20% @ 35÷400Hz (consumption 6VA)
- From 2005 on: switching circuit. 90÷230 Vac or Vdc ±15% @ 0÷400 Hz (cons. 5VA)

Display: reverse red LCD with LED backlight

Voltmeter inputs: VL1, VL2, VL3, N up to 350V phase-neutral, 600V phase-to-phase, 35÷400 Hz

Voltmeter input impedance: 2 M

Voltage input overload: max 850V phase-neutral

Current inputs: AL1, AL2, AL3, COM. Consumption 1 VA..3 or 2 external curr.transf 5A required.

Measuring range: 0-120% In

Sensitivity: current 20 mA ; voltage 10 V

Over current: withstand 50 amps for 1 sec.

Number of scales: 1 voltage scale, 2 current scales

Measurements: True R.M.S. up to 25th harmonic = 1250Hz with fundamental @50 Hz

Sampling frequency: 2.5 kHz.

Accuracy: < 0.5% for Voltage and current and Power

Connection: Single phase or three phase star, three phase delta, or diphase systems

Weight: 0.6 Kg

Protection level: instrument IP20, front panel IP40

Temperature range: -10°C ÷ + 50°C

Relative humidity range: (R.H.): from 20% to 90%.

Condensation: non condensing

Relay output: V 250 max 120mA A.C. max