

Other Protistor® Fuses BS88-4 Fuses 36x27, 2X36x27, - 250 VAC



Extremely high breaking capacity fuses:
protection of power semiconductors as per IEC standard 60269.1 and 4

250 V voltage rating COMPLYING WITH IEC 33

gr class (ratings from 50 to 350 a URGG - 300 to 700 A URGH) AS PER VDE 636-23 AND IEC 60269.4

aR CLASS (RATINGS FROM 400 to 525 A URGG - 800 to 1050 A URGH) COMPLYING WITH VDE 636-23 AND IEC 60269.4

TWO MODELS COMPLYING WITH BS 88-4
- WITHOUT INDICATOR
- WITH SEPARATE TRIP-INDICATOR

Main Characteristics

Voltage rating U_N (V)	Size	Class	Current rating I_N (A)	Pre-arcing $I^2t @ 1 \text{ ms}$ I^2tp (A ² s)	Total clearing $I^2t @ U_N$ A ² s	Watts loss		Tested Breaking capacity
						$0.8 I_N$	I_N	
250V	36x27	URGG	50	120	500	4.75	9.5	100k A @ 250 V
			75	330	1380	6.3	12.6	
			100	745	3060	7.8	15.7	
			125	1340	5500	9.1	18.2	
			150	1930	7950	10.8	21.6	
			200	4020	16400	13.5	27.0	
			250	5350	30000	16.3	32.6	
			300	7290	49600	18.6	37.2	
			350	18000	74000	21	42.0	
			400	25100	128000	23.4	46.7	
			450	33500	170000	27.1	54.1	
	500	43000	219000	30.4	60.8			
	525	48200	245000	33.2	66.4			
	2x36x27	URGH	300	7700	31800	21.6	43.2	100k A @ 250 V
			350	11500	48700	24.3	48.6	
			400	16000	65600	27	54.0	
			500	29100	120000	32.6	65.2	
			600	48200	198500	37.2	74.4	
			700	72000	276000	42.0	84.0	
800			100000	512000	46.7	93.4		
1050			193000	980000	66.4	132.8		

Minimum operating voltage for separate or integrated trip indicator = 20 V



Other Protistor® Fuses

BS88-4 Fuses

36x27, 2X36x27, - 250 VAC

CP 36x27 Without trip-indicator

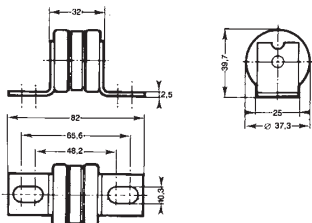

Size	Designation	Ref. Number	Pack.	Catalog Number
36x27	2.5 URGG 36/50	J080945		BS36UG25V50
	2.5 URGG 36/75	K080946		
	2.5 URGG 36/100	L080947		BS36UG25V100
	2.5 URGG 36/125	R082470		BS36UG25V125
	2.5 URGG 36/150	Q082469		BS36UG25V150
	2.5 URGG 36/200	P082468	3	BS36UG25V200
	2.5 URGG 36/250	N082467	(170g)	BS36UG25V250
	2.5 URGG 36/300	M082466		BS36UG25V300
	2.5 URGG 36/350	L082465		BS36UG25V350
	2.5 URGG 36/400	G075538		BS36UG25V400
	2.5 URGG 36/450	H075539		BS36UG25V450
	2.5 URGG 36/500	J075540		BS36UG25V500
	2.5 URGG 36/525	K075541		BS36UG25V525

CP 36x27 With built-in trip-indicator

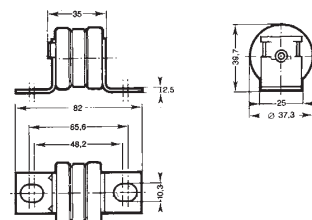

Size	Designation	Ref. Number	Pack.	Catalog Number
36x27	2.5 URGG 36T50	F080942		BS36UG25V50T
	2.5 URGG 36T75	G080943		BS36UG25V75T
	2.5 URGG 36T100	H080944		BS36UG25V100T
	2.5 URGG 36T125	W082382		BS36UG25V125T
	2.5 URGG 36T150	V082381		BS36UG25V150T
	2.5 URGG 36T200	T082380	3	BS36UG25V200T
	2.5 URGG 36T250	S082379	(170g)	BS36UG25V250T
	2.5 URGG 36T300	R082378		BS36UG25V300T
	2.5 URGG 36T350	O082377		BS36UG25V350T
	2.5 URGG 36T400	L075542		BS36UG25V400T
	2.5 URGG 36T450	M075543		BS36UG25V450T
	2.5 URGG 36T500	N075544		BS36UG25V500T
	2.5 URGG 36T525	P075545		BS36UG25V525T

Microswitch MC 36 GR 2.5 - Ref. P 092496

CP 36x27 With separated trip-indicator BS88

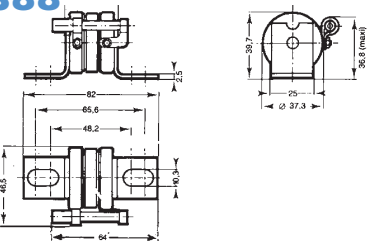

Size	Designation	Ref. Number	Pack.	Catalog Number
36x27	2.5 URGG 36P50	C080939		BS36UG25V50P
	2.5 URGG 36P75	D080940		BS36UG25V75P
	2.5 URGG 36P100	E080941		BS36UG25V100P
	2.5 URGG 36P125	Y081004		BS36UG25V125P
	2.5 URGG 36P150	X081003		BS36UG25V150P
	2.5 URGG 36P200	W081002	3	BS36UG25V200P
	2.5 URGG 36P250	V081001	(185g)	BS36UG25V250P
	2.5 URGG 36P300	T081000		BS36UG25V300P
	2.5 URGG 36P350	S080999		BS36UG25V350P
	2.5 URGG 36P400	V075504		BS36UG25V400P
	2.5 URGG 36P450	W075505		BS36UG25V450P
	2.5 URGG 36P500	X075506		BS36UG25V500P
	2.5 URGG 36P525	Y075507		BS36UG25V525P

Microswitch MC 36 GR 2.5 N - Ref. Y 310005

CP 2x36x27 Without trip-indicator

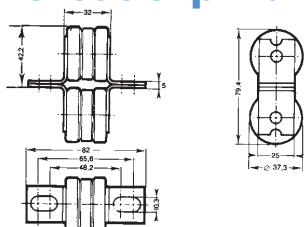

Size	Designation	Ref. Number	Pack.	Catalog Number
2x36x27	2.5 URGH 236/300	K082464		BS236UH25V300
	2.5 URGH 236/350	J082463		BS236UH25V350
	2.5 URGH 236/400	H082462		BS236UH25V400
	2.5 URGH 236/500	G082461		BS236UH25V500
	2.5 URGH 236/600	F082460		BS236UH25V600
	2.5 URGH 236/700	E082459	3	BS236UH25V700
	2.5 URGH 236/800	Q075546	(290g)	BS236UH25V800
	2.5 URGH 236/900	R075547		BS236UH25V900
	2.5 URGH 236/1000	S075548		BS236UH25V1000
	2.5 URGH 236/1050	T075549		BS236UH25V1050

CP 2x36x27 With built-in trip-indicator

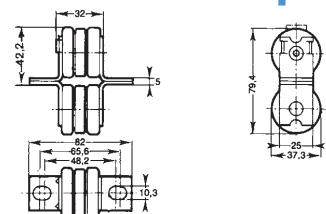

Size	Designation	Ref. Number	Pack.	Catalog Number
2x36x27	2.5 URGH 236T300	P082376		BS236UH25V300T
	2.5 URGH 236T350	N082375		BS236UH25V350T
	2.5 URGH 236T400	M082374		BS236UH25V400T
	2.5 URGH 236T500	L082373		BS236UH25V500T
	2.5 URGH 236T600	K082372		BS236UH25V600T
	2.5 URGH 236T700	J082371	3	BS236UH25V700T
	2.5 URGH 236T800	V075550	(290g)	BS236UH25V800T
	2.5 URGH 236T900	R075501		BS236UH25V900T
	2.5 URGH 236T1000	S075502		BS236UH25V1000T
	2.5 URGH 236T1050	T075503		BS236UH25V1050T

Microswitch MC 36 GR 2.5 N - Ref. P 092496

Other Protistor® Fuses BS88-4 Fuses 36x27, 2X36x27, - 250 VAC

CP 36x27 With separated trip-indicator BS88

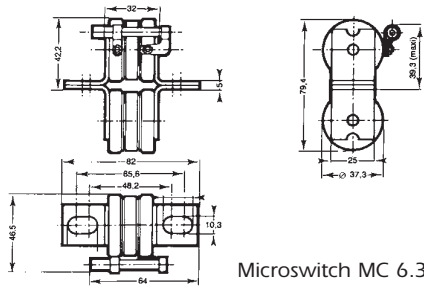

Microswitch MC 6.3 GR 2.5 N - Ref. Y 310005

Size	Designation	Ref. Number	Pack.	Catalog Number
2x36x27	2.5 URGH 236P300	R080998		BS236UH25V300P
	2.5 URGH 236P350	O080997		BS236UH25V350P
	2.5 URGH 236P400	P080996		BS236UH25V400P
	2.5 URGH 236P500	N080995		BS236UH25V500P
	2.5 URGH 236P600	M080994	3	BS236UH25V600P
	2.5 URGH 236P700	L080993	(900g)	BS236UH25V700P
	2.5 URGH 236P800	Z075508		BS236UH25V800P
	2.5 URGH 236P900	A075509		BS236UH25V900P
2.5 URGH 236P1000	B075510		BS236UH25V1000P	
2.5 URGH 236P1050	C075511		BS236UH25V1050P	

Electrical characteristics

Times vs current characteristics

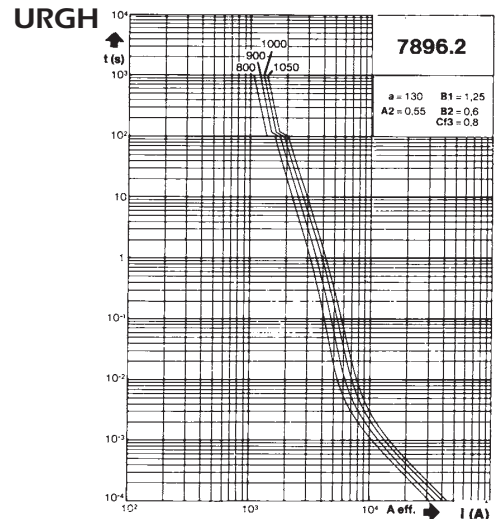
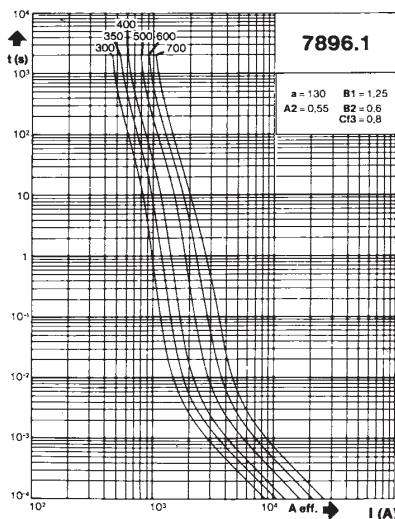
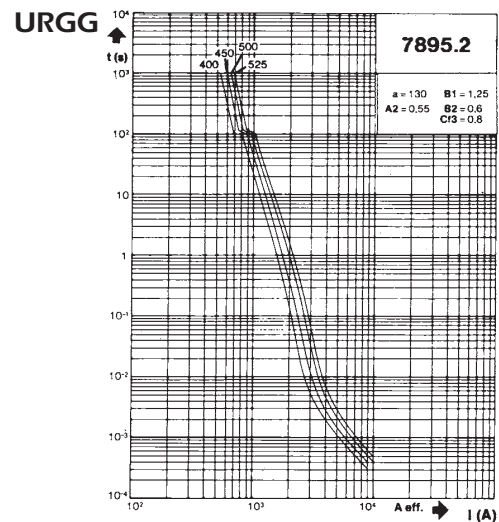
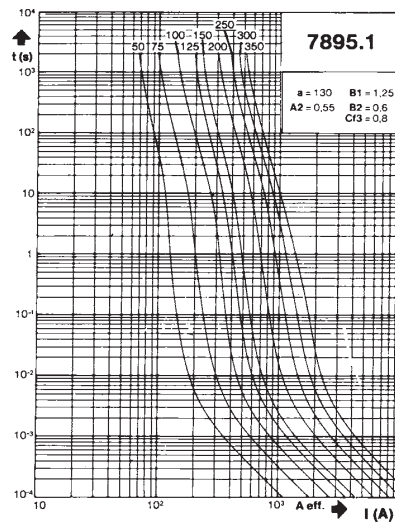

- These curves indicate, for each rated current, the pre-arcing time vs. the R/M.S. pre-arcing current.
- Tolerance for the mean pre-arcing current $\pm 10\%$



Other Protistor® Fuses BS88-4 Fuses 36x27, 2X36x27, - 250 VAC

Corrective factor - Peak arc voltage

Corrective factor

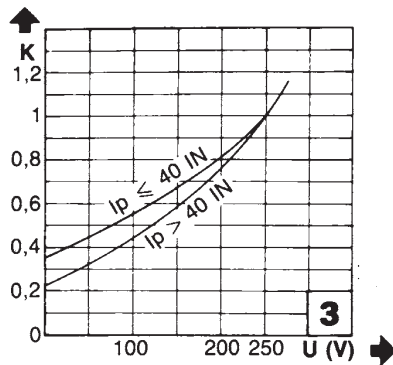

URGG

From 50 to 350 A

URGH

From 300 to 700 A

Peak arc voltage

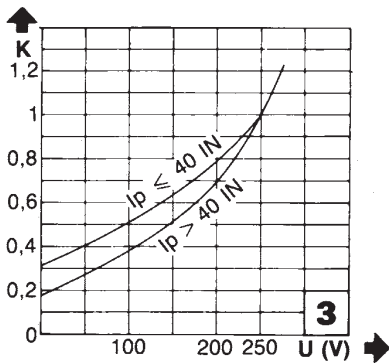
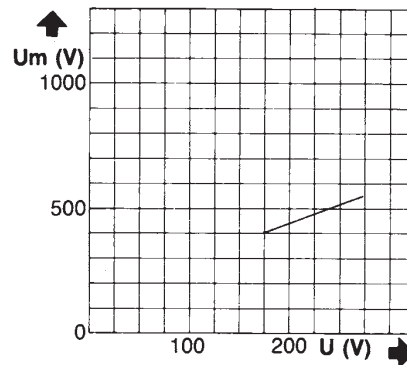

URGG

From 400 to 525 A

URGH

From 800 to 1050 A

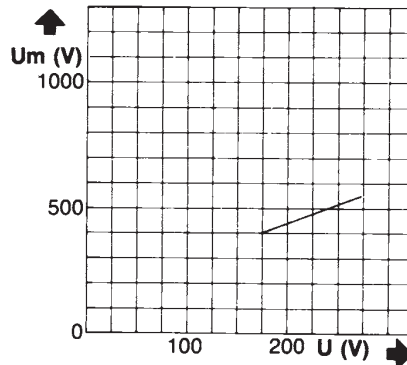

Corrective factor

* The mean curves show the variation of the total clearing time (I^2t_t) and the total clearing duration t_t as a function of operating voltage U

Peak arc voltage

This curve shows the peak value U_m of the arc voltage which appears across the fuse link as a function of the operating voltage U @ $\cos \varphi = 0.15$.

Other Protistor® Fuses BS88-4 Fuses

Microswitches for BS88-4 Protistor®

MICROSWITCH SYSTEMS ADAPTED
TO THE FOLLOWING FUSES:

- BS88 - 4 separated trip-indicator
- BS88 - 4 built-in trip-indicator

Main Characteristics

Code	AC Insulation voltage rating (***)	Positive operating voltage/current	Current rating	Current	Interrupting rating						AC voltage withstand test (*)	Impulse voltage test Uimp1.2/50 μs (**)	Fire class according to UL 94
					Non inductive circuit			Inductive circuit : L/R = 25ms					
					30V	110V	250V	30V	110V	250V			
MC 6,3 GR 2-5 N	1000 V	20 V 100 mA	5 A	50/60 Hz	-	5 A	0,3 A	-	3 A	2 A	3.5 kV	-	H.B.
				DC	4 A	0.4 A	-	3 A	0.4 A	-			
MC 36 GR 2-5	1000 V	20 V 100 mA	5 A	50/60 Hz	-	5 A	5 A	-	5 A	5 A	7.5 kV	-	
				DC	4 A	0.4 A	-	2 A	0.4 A	-			

* Between power circuit and microswitch terminals as per IEC 60 and 694 (50/60 Hz 1 min duration in dry air)

** Between power circuit and microswitch terminals Uimp: impulse voltage as per IEC 947-1

*** Between power circuit and microswitch terminals

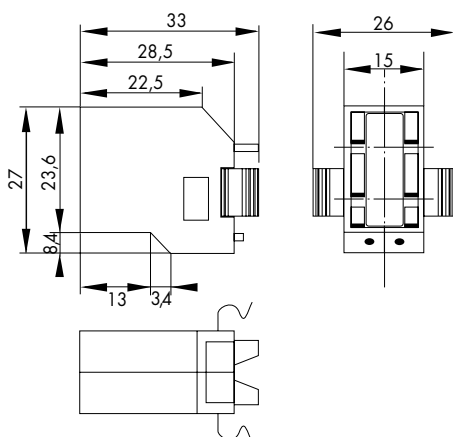
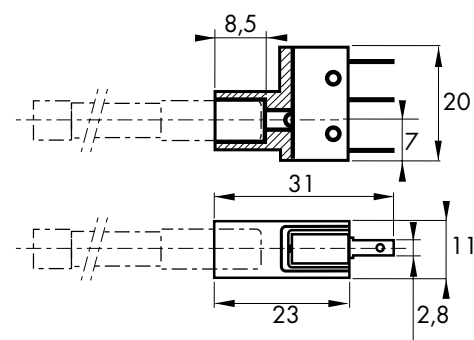

Catalog Number	Ref. Number	Weight (g)	Pack.
MC 6,3 GR 2-5 N (for separate trip-indicator)	Y 310015	10	3

Catalog Number	Ref. Number	Weight (g)	Pack.
MC 36 GR 2-5 (for built-in trip-indicator)	P 092496	10	3