

Protistor® Square-body Fuses PSC gGR sizes 000/00 gGR - 690 VAC DIN 00/000 (full range)

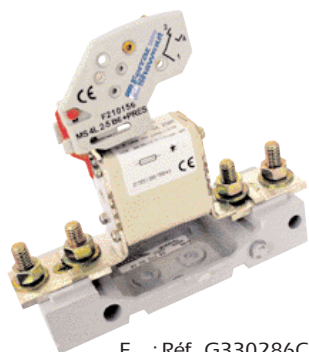

F : Réf. D302108
MC: Réf. F210156C



F : Réf. G330286C
PF : Réf. Q098040C
MC: Réf. F210156C

gGr: two functions

A combination of: Power supply cable protection (gG curve)

- Compliance with the standardized gate values for gG curves as per EN 60269-2,
- Low power dissipation, similar to a gG fuse, no current derating in holders,
- No derating for variable currents,
- Good withstand to overloads,
- Same thermal definition as a gG curve,
- Unnecessary to dimension the cable cross sectional area large in comparison to UR protection,
- Range designed for the new voltage of 690V \pm 10%.

Power semi-conductor protection (Fast R curve)

- Fast curve for fault currents and short-circuit currents under 20 In,
- Tested breaking capacity 100 kA (00) or 170 kA (000) at 690 V,
- Very current limiting, which in turn limits electrodynamic forces in the circuit downstream,
- Low I²t
- Compact footprint: only one fuse instead of two or a relay plus a fuse,
- DC performances 360 to 550V for I/R = 10 ms,
Semi-conductor protection checked in the same way as a fuse.

Applications: "off-board" protection

- AC and DC speed governor,
- Soft starter,
- Static relay,
- Current regulator,
- Inverter (IGBT module disconnecter in parallel),
Battery.

Connection technologies offered

- Solid blades (as per DIN 43620) with visual blown fuse indicator and striker to actuate a microswitch, MS4L2-5B + PRES (ref. F210156C or G210157C),
- DIN 80 brackets (as per DIN 43653) with visual blown fuse indicator and striker indicator to actuate a microswitch, MS4L2-5B + PRES.
- With these two technologies the designer can choose a fuse according to the types of holders desired.

Semiconductor (AC) fuses



Protistor® Square-body Fuses PSC gGR sizes 000/00 gGR - 690 VAC DIN 00/000 (full range)

- EN 60269-2-1 compliant
- Compliance with gG gate values on melting and not melting
- Low dissipated power
- No derating for variable current
- Good withstand to repeated overloading
- Withstand to exceptional overloads (same as Protistor fuses)
- Cable protection



Functionalities

Two functions:

- to protect cables from overloads,
- to protect semi-conductors from short-circuits.

Electrical characteristics

Size 000

Voltage Rating (VAC)	Size	Current Rating In (A)	Prearcing Pt @ 1 ms Ptp (A²s)	Total Pt (A²s)		Power losses @ In (W)	Tested breaking capacity	Estimated breaking capacity
				@ Un	@ 400V			
690	000	16	45	280	230	2.5		
		20	60	380	310	3		
		25	130	830	700	3.5		
		32	210	1350	1150	4	170 kA	200 kA
		40	350	2200	1900	5	@	@
		50	550	3500	3000	6	690 V	690 V
		63	1000	6100	5150	7		
		80	1700	11000	9200	8		
		100	3900	25000	21000	9		

Size 00

Voltage Rating (VAC)	Size	Current Rating In (A)	Prearcing Pt @ 1 ms Ptp (A²s)	Total Pt (A²s)		Power losses @ In (W)	Tested breaking capacity	Estimated breaking capacity
				@ Un	@ 400V			
690	00	16	45	280	230	2.5		
		20	60	390	290	3.2		
		25	120	750	560	4		
		32	240	1550	1150	5		
		40	350	2250	1680	5.5		
		50	540	3500	2600	6.5	100 kA	200 kA
		63	1060	6750	5000	7.6	@	@
		80	1900	12100	9000	9.5	690 V	690 V
		100	3900	24150	18000	11		
		125	6950	45000	33500	13		
		160	13500	82000	61000	16		
		200	27600	160000	120000	18		

Protistor® Square-body Fuses PSC gGR sizes 000/00 gGR - 690 VAC DIN 00/000 (full range)

Size 000

German standard
DIN 43653/000
DIN 80

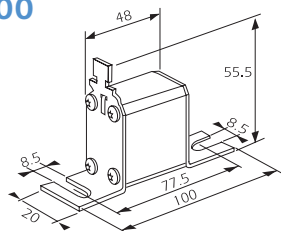

German blade-style
fuse standard
DIN 43620/000

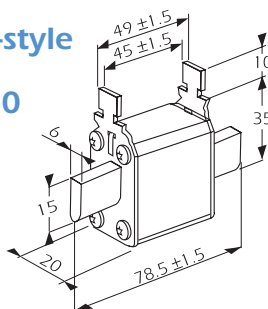

Size 00

German standard
43653/00 - DIN 80

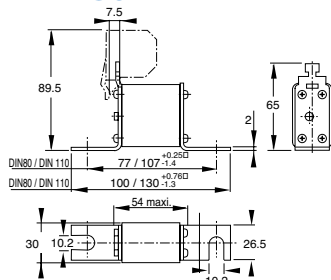

German blade-style
fuse standard 43620/00

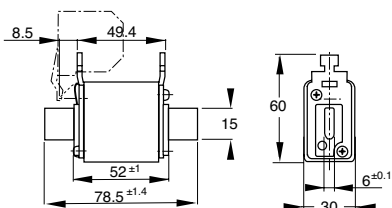

No derating:

I/In = I rms of use/fuse rating
In the different holders = no derating

Microswitches:

Ref. F210156: 6.3 mm clips
Ref. G210156: 2.8 mm clips

690 V gGR fuse holders and supports

Current [A]	Designation	Ref. Number	I/In*	Weight [g]	Pack.	Catalog Number
16	6,9 gGR 000 D08L 016	H302112	1	120	3	DN000GR69V16L
20	6,9 gGR 000 D08L 020	J302113	1	120	3	DN000GR69V20L
25	6,9 gGR 000 D08L 025	K302114	1	120	3	DN000GR69V25L
32	6,9 gGR 000 D08L 032	L302115	1	120	3	DN000GR69V32L
40	6,9 gGR 000 D08L 040	M302116	1	120	3	DN000GR69V40L
50	6,9 gGR 000 D08L 050	N302117	1	120	3	DN000GR69V50L
63	6,9 gGR 000 D08L 063	P302118	1	120	3	DN000GR69V63L
80	6,9 gGR 000 D08L 080	Q302119	1	120	3	DN000GR69V80L
100	6,9 gGR 000 D08L 100	R302120	1	120	3	DN000GR69V100L
Microswitch		F210156				MS4L2-5B6PRES
		G210157				MS4L2-5B2PRES

16	6,9 gGR 000 PV 016	X302102	1	150	3	NH000GR69V16PV
20	6,9 gGR 000 PV 020	Y302103	1	150	3	NH000GR69V20PV
25	6,9 gGR 000 PV 025	Z302104	1	150	3	NH000GR69V25PV
32	6,9 gGR 000 PV 032	A302105	1	150	3	NH000GR69V32PV
40	6,9 gGR 000 PV 040	B302106	1	150	3	NH000GR69V40PV
50	6,9 gGR 000 PV 050	C302107	1	150	3	NH000GR69V50PV
63	6,9 gGR 000 PV 063	D302108	1	150	3	NH000GR69V63PV
80	6,9 gGR 000 PV 080	E302109	1	150	3	NH000GR69V80PV
100	6,9 gGR 000 PV 100	F302110	1	150	3	NH000GR69V100PV
Microswitch		F210156				MS4L2-5B6PRES
		G210157				MS4L2-5B2PRES
Extractor handle		P215592			1	NH HANDLE

20	6,9 gGR 00 D08L 020	T330297	1	140	3	DN00GR69V20L
25	6,9 gGR 00 D08L 025	V330298	1	140	3	DN00GR69V25L
32	6,9 gGR 00 D08L 032	W330299	1	140	3	DN00GR69V32L
40	6,9 gGR 00 D08L 040	X330300	1	140	3	DN00GR69V40L
50	6,9 gGR 00 D08L 050	Y330301	1	140	3	DN00GR69V50L
63	6,9 gGR 00 D08L 063	G330286	1	140	3	DN00GR69V63L
80	6,9 gGR 00 D08L 080	H330287	1	140	3	DN00GR69V80L
100	6,9 gGR 00 D08L 100	J330288	1	140	3	DN00GR69V100L
125	6,9 gGR 00 D08L 125	K330289	1	140	3	DN00GR69V125L
160	6,9 gGR 00 D08L 160	L330290	1	140	3	DN00GR69V160L
200	6,9 gGR 00 D08L 200	M330291	1	140	3	DN00GR69V200L
Microswitch		F210156				MS4L2-5B6PRES
		G210157				MS4L2-5B2PRES

20	6,9 gGR 00 PV 020	N330292	1	210	3	NH00GR69V20PV
25	6,9 gGR 00 PV 025	P330293	1	210	3	NH00GR69V25PV
32	6,9 gGR 00 PV 032	Q330294	1	210	3	NH00GR69V32PV
40	6,9 gGR 00 PV 040	R330295	1	210	3	NH00GR69V40PV
50	6,9 gGR 00 PV 050	S330296	1	210	3	NH00GR69V50PV
63	6,9 gGR 00 PV 063	A330280	1	210	3	NH00GR69V63PV
80	6,9 gGR 00 PV 080	B330281	1	210	3	NH00GR69V80PV
100	6,9 gGR 00 PV 100	C330282	1	210	3	NH00GR69V100PV
125	6,9 gGR 00 PV 125	D330283	1	210	3	NH00GR69V125PV
160	6,9 gGR 00 PV 160	E330284	1	210	3	NH00GR69V160PV
200	6,9 gGR 00 PV 200	F330285	1	210	3	NH00GR69V200PV
Microswitch		F210156 (only)				MS4L2-5B6PRES
Extractor handle		P215592			1	NH HANDLE

Type of fuse	Nb. poles	References for mounting on 35 mm DIN rail	References for panel mounting
Solid blades size 000/00 IPXX	1	R216192	F215170
	2	F218758	A217212
	3	V219277	F217723
	4	Z223007	S219275
Solid blades size 000/00 IP20 w/o microswitch	1	S218240	-
	3	S229119	-
DIN 80 bracket size 000 IPXX	1	-	C220710
DIN 80 bracket size 00 IPXX	1	-	O098040
DIN 80 blades size 000 IP20 w/o microswitch	1	B227218	-
DIN 80 blades size 000 IP20 for microswitch	1	C227219	-
DIN 80 blades size 00 IP20 w/o microswitch	1	V227672	-
DIN 80 blades size 00 IP20 for microswitch	1	W227673	-
ITCP range	1		



Protistor® Square-body Fuses PSC gGR sizes 000/00 gGR - 690 VAC DIN 00/000 (full range)



F : Réf. D302108C
MC: Réf. F210156C

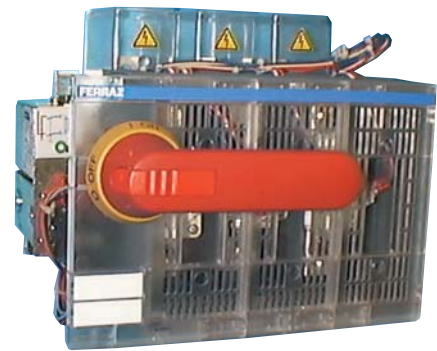

F : Réf. G330286C
PF : Réf. Q098040C
MC: Réf. F210156C

ITCP: Réf. G210410A
F : Réf. M330291C

Choice and references of gGR fuse holders

	Type of support	Characteristics	Nb. Poles	Solid blade size 000/00		DIN 80 bracket		Fuse microswitch (2)
				Reference Number	Fuse extraction handle	Size 000	Size 00	
CEI 60269-2	Fuse holders	No protection (1) Screw connection for eye lug or bar for 35 mm DIN rail	1	R216192	P215592			F2101546 or G210157
			2	F218758				
			3	V219277				
			4	Z223007				
		No protection (1) Screw connection for eye lug or bar on panels	1	F215170	P215592	C220710	Q098040	F210156 or G210157
			2	A217212				
		Protect led to IP20 Screw connection for eye lug or bar for DIN rail	3	S218240	P215592	W/o microswitch B227218	C227219	
			1	S229119				
CEI 60947-3	Switch disconnecter	Horizontal Linocur AC23	2	N216626 N222882 B218685 C201781 Y212035 W213574	P215592			F210156 or G210157
			3		P215592			
			3		P215592			
	Switch with front control handle	ITC 160M III 00 Front handle Inside/outside Complete	3	K227824	P215592			
			3	F210409	P215592			
Switch with side control handle	ITC 160M III 00 Side handle Outside Complete	3	J227823	P215592				
ITCP	ITCP	3		P215592				G210410

(1) No protection against accidental contact with live parts IPXX.

(2) F210156C microswitch: 6.3 mm clips
G210157C microswitch: 2.8 mm clips

Semiconductor (AC) fuses

Protistor® Square-body Fuses PSC gGR sizes 000/00 gGR - 690 VAC DIN 00/000 (full range)

Amplitude of current interrupted

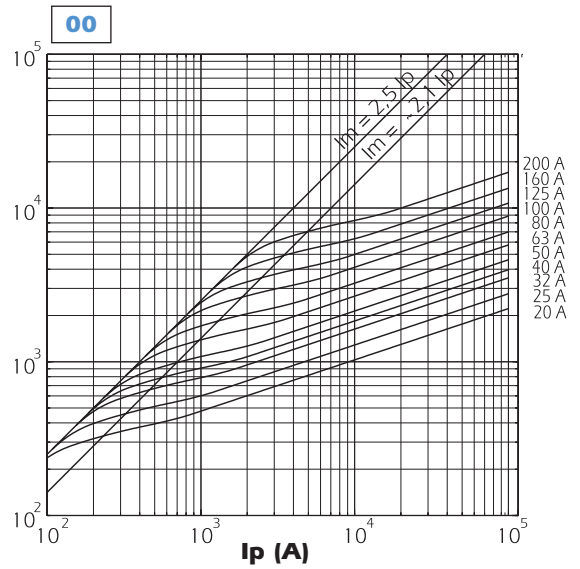
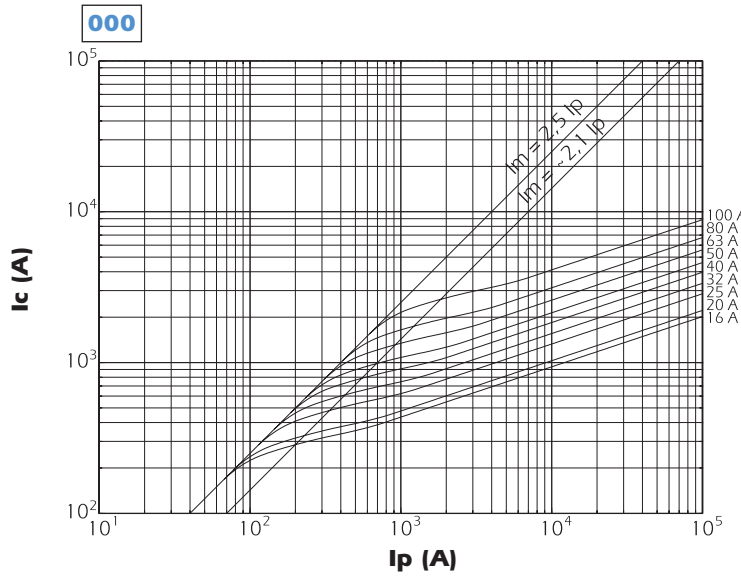

DC working voltage possibilities

Size 00

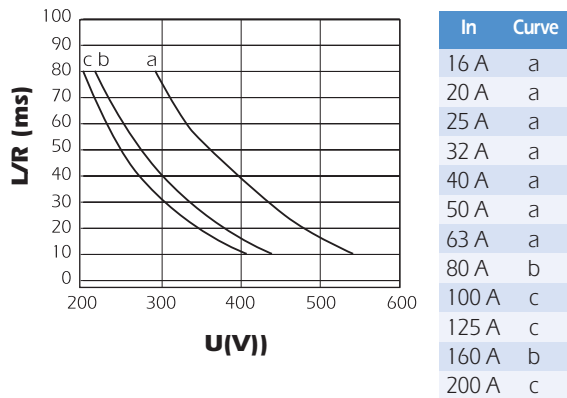

Size 000

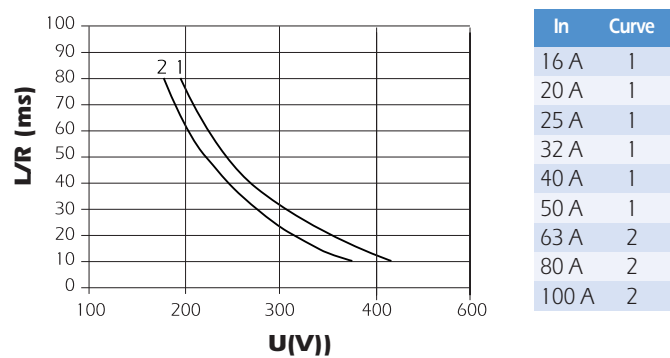

Size 00 and Size 000

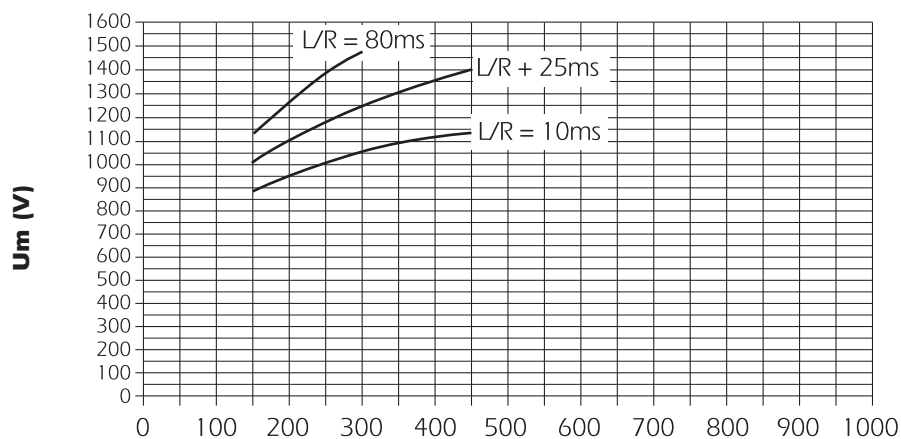

Semiconductor (AC) fuses



Protistor® Square-body Fuses

PSC gGR sizes 000/00

gGR - 690 VAC DIN 00/000 (full range)

Time/current characteristics

TOLERANCE ON PRE-ARCING CURRENT +/- 8%

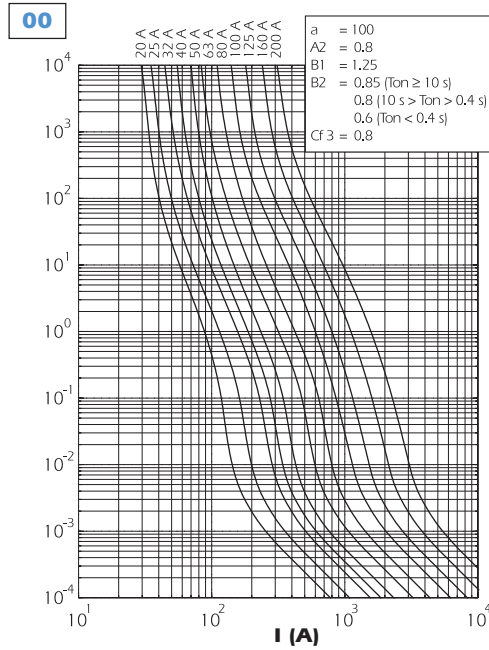
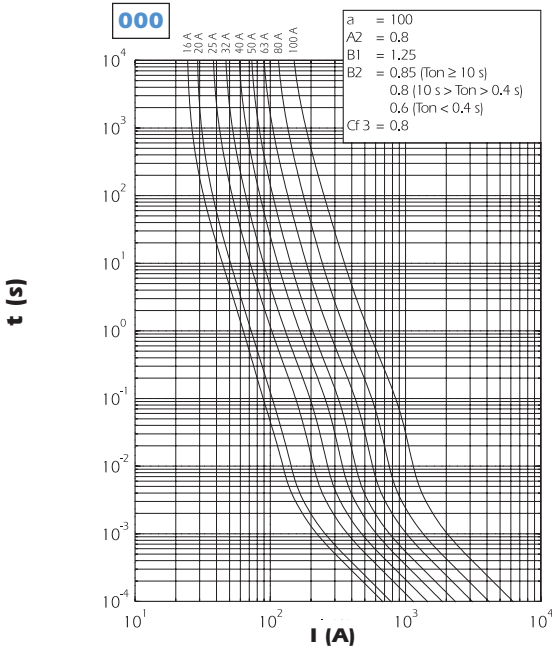

Dissipated power

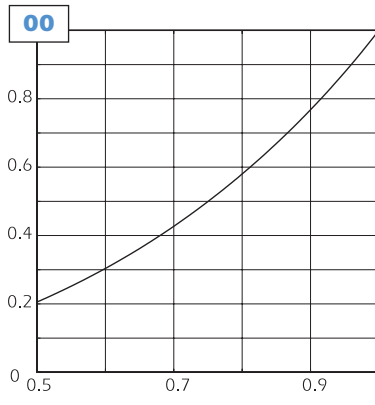
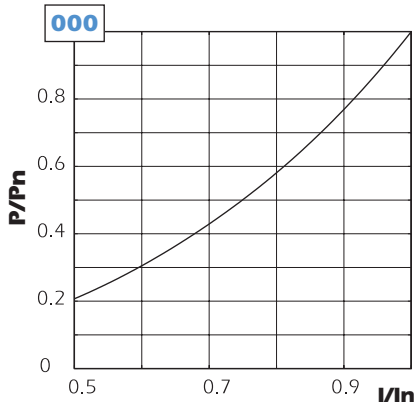

Breaking voltage

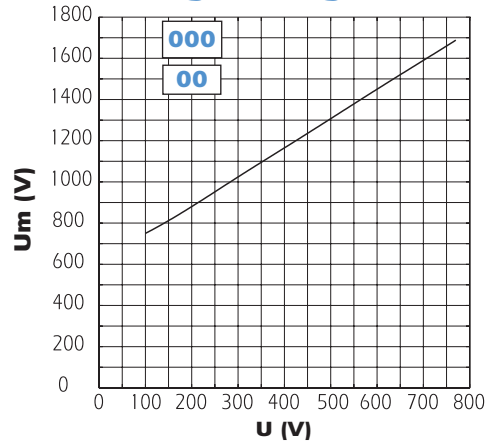

Maximum total operating I²t and total operating time

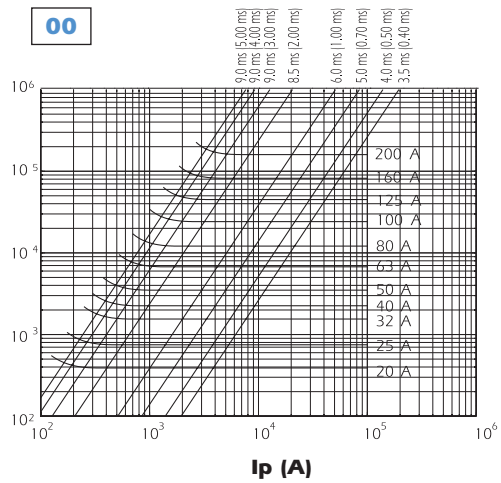
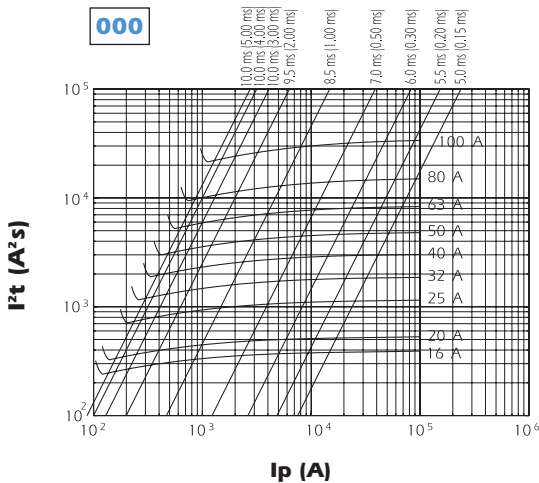

Protistor® Square-body Fuses PSC gR/aR sizes 000/00 Microswitches for PSC sizes 000/00 and NH

MICROSWITCH SYSTEMS ADAPTED TO THE FOLLOWING FUSES:

- PSC sizes 000/00 (brackets) DIN43653
- NH Fuses (plain blades) see details in "General Purpose IEC Fuses" section
- NH plain blades 690 VAC Protistor square-body Fuses

MS 4L 2-5



Main Characteristics

Code	AC Insulation voltage rating (***)	Positive operating voltage/current	Current rating	Current	Interrupting rating						AC voltage withstand test (*)	Impulse voltage test Uimp1.2/50 µs (**)	Fire class according to UL 94
					Non inductive circuit			Inductive circuit : L/R = 25ms					
					30V	110V	250V	30V	110V	250V			
MS 4L 2-5 B2 + Pres	1000 V	20 V 100 mA	5 A	50 Hz	4A	4A	5A	-	5A	5 A	12 kV	16 kV	V0
				DC	-	-	-	-	2 A	0,4 A	8 kV	13 kV	
MS 4L 2-5 B6 + Pres	1000 V	20 V 50 mA	10 A	50/60 Hz	10 A	10 A	10 A	10 A	10 A	10 A	8 kV	10 kV	V0
				DC	8 A	0,4 A	0,2 A	4 A	0,2 A	0,1 A			

* Between power circuit and microswitch terminals as per IEC 60 and 694 and NFC 64010 (50/60 Hz 1 min duration in dry air)
 ** Between power circuit and microswitch terminals Uimp: impulse voltage as per IEC 60947-1
 *** Between power circuit and microswitch terminals

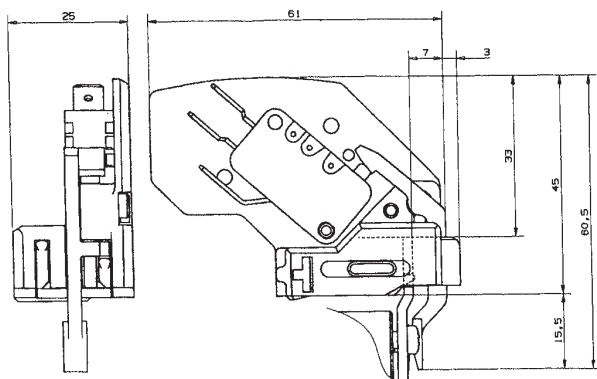

Designation	Ref. Number	Weight (g)	Pack.	Catalog Number
MS 4L 2-5 B6 + PRES (Fig. 1) (1)	F210156	30	3	MS 4L2-5B6PRES
MS 4L 2-5 B2 + PRES (Fig. 2) (2)	G210157	26	3	MS 4L2-5B2PRES

Automatically resettable, these microswitch systems indicate fuse presence (PRES) and proper mounting.
 In case of improper mounting or fuse melting, this is indicated (terminal 1-4 closed)

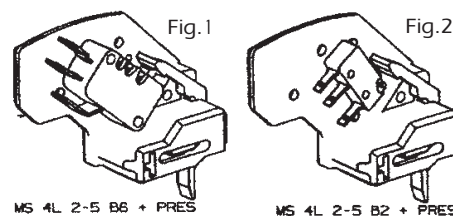
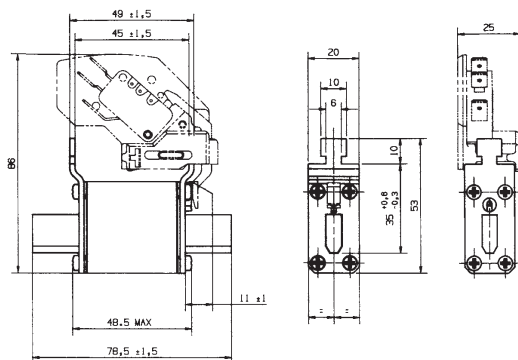

(1) 6.3 mm clips
 (2) 2.8 mm clips