

Protistor® Square-body Fuses PSC aR sizes 3x - 450V to 700 VAC Main characteristics

450 TO 700VAC / 63 TO 2800A

 Recognized

- Exceptionally low I^2t , Watt losses.
- Non-magnetic construction,
- Highly reliable low voltage
- Trip-indicator system, conformity to UL, IEC, DIN and VDE standards.
- Increased technical performance
 - Higher ratings
 - Reduction in volume and weight



This fuse preselection table indicates, for each size:

- rated current (or rating) I_n
- pre-arcing I^2t (I^2t_p) at 1 ms
- total operating I^2t (I^2t_t) at 660 V, $f=50\text{Hz}$ $\cos \varphi=0.15$, and for a total operating time from 8 to 10 ms
- dissipated power P_n at the rated current I_n , and at $0.8 I_n$, in steady state
- breaking capacity at various voltages, checked by tests made in accordance with IEC and American standards.

Semiconductor (AC) fuses



Protistor® Square-body Fuses PSC aR sizes 3x - 450V to 700 VAC Main characteristics

Estimated breaking capacity: 300kA

Size	Nominal Voltage (VAC)		Ampere Rating (A)	Pre-arcing I ² t @ 1ms (kA ² s)	Total I ² t @ 660V (*) @ Un (kA ² s)	Power Pn (W)		Tested Breaking capacity (kA)	
	IEC	USA				End contact	Blades	IEC @ 690V (*) @ Un	USA @ 700V (*) @ Un
30	690	700	50	0,116	0,62	9	9	200	200
			63	0,2	1,1	14	14		
			80	0,33	1,8	19	19		
			100	0,47	2,5	26	26		
			125	0,85	4,5	30	30		
			160	1,6	8,5	37	37		
			200	3	15,5	42	43		
			250	5,8	30	48	50		
			315	12	62	53	55		
			350	15,5	80	57	60		
			400	23	120	60	65		
			450	26	150	80	88		
			500	41	240	80	88		
			550	52	300	80	90		
31	690	700	630	84	450(*)	85	95	200	200
			160	1,3	7	35	35		
			200	2,6	13,5	45	45		
			250	4,7	25	52	52		
			315	7,5	40	65	65		
			350	10,5	55	67	67		
			400	19	100	68	68		
			450	26,5	140	70	70		
			500	37	195	70	72		
			550	52	280	70	75		
			630	75	390	75	85		
			700	95	490	85	95		
			800	140	800	105	120		
			315	5,2	28,9	71	71		
350	8,9	48,8	71	74					
400	15	80	72	75					
450	22	115	77	80					
500	28	145	85	90					
550	37	195	90	95					
630	54	280	95	105					
700	76	400	100	110					
800	115	600	110	120					
900	170	900	110	125					
1000	240	1250	115	135					
1100	270	1450(*)	140	165					
1250	410	1950(*)	150	180					
1400	555	2300(*)	160	200					
1600	870	3600(*)	165	205					
1800	1050	3700(*)	195	230					
32	690	700	450	13,45	74,1	84	88	200	200
			500	19	100	105	105		
			550	27	140	105	110		
			630	40	210	110	120		
			700	55	300	115	125		
			800	95	490	120	130		
			900	135	700	120	135		
			1000	170	900	135	155		
			1100	240	1260	135	160		
			1250	350	1850	150	180		
			1400	480	2500	160	200		
			1500	500	2500(*)	210	240		
			1600	555	2900(*)	210	240		
			1800	720	3870(*)	225	260		
2000	950	4500(*)	250	290					
2250	1250	5160(*)	280	320					
2500	1870	6540(*)	280	330					
33	690	700	800	60	320	144	144	200	200
			1000	110	590	165	165		
			1250	220	1100	190	190		
			1400	300	1600	200	200		
			1600	450	2400	220	220		
			1800	700	3500	225	225		
			2000	950	5000	235	235		
			2200	1100	5250(*)	280	280		
			1000	76	395	220	220		
			1250	160	850	230	230		
			1400	225	1200	240	240		
			1600	375	1900	250	250		
			1800	530	2800	250	250		
			2000	700	3100(*)	280	280		
2200	950	4400(*)	280	280					
2500	1400	6600(*)	310	310					
2800	1900	8800(*)	330	330					
2X32	690	700	800	60	320	144	144	200	200
			1000	110	590	165	165		
			1250	220	1100	190	190		
			1400	300	1600	200	200		
			1600	450	2400	220	220		
			1800	700	3500	225	225		
2x33	690	700	2000	950	5000	235	235	150(*)	150(*)
			2200	1100	5250(*)	280	280		
			1000	76	395	220	220		
			1250	160	850	230	230		
			1400	225	1200	240	240		
			1600	375	1900	250	250		
2x33	600	650	2000	700	3100(*)	280	280	160(*)	160(*)
			2200	950	4400(*)	280	280		
			2500	1400	6600(*)	310	310		
			2800	1900	8800(*)	330	330		

For others Ampere ratings consult us
12/04

Semiconductor (AC) fuses



Protistor® Square-body Fuses

PSC aR sizes 3x - 450V to 700 VAC

IEC Terminals German - 30 - 33 Blades (Din 80)

Size	Designation	Reference Number		Weight (g)	I/IN Base		Catalog Number DIN 80
		DIN 80			L98772 F98031	F98560 L91941	
30	6,9 URD 30 D08A 0050	F301926		290	1	1	PC30UD69V50A
	6,9 URD 30 D08A 0063	E300108			1	1	PC30UD69V63A
	6,9 URD 30 D08A 0080	F300109			1	1	PC30UD69V80A
	6,9 URD 30 D08A 0100	G300110			1	1	PC30UD69V100A
	6,9 URD 30 D08A 0125	H300111			1	1	PC30UD69V125A
	6,9 URD 30 D08A 0160	J300112			1	1	PC30UD69V160A
	6,9 URD 30 D08A 0200	K300113			1	1	PC30UD69V200A
	6,9 URD 30 D08A 0250	L300114			1	1	PC30UD69V250A
	6,9 URD 30 D08A 0315	M300115			1	1	PC30UD69V315A
	6,9 URD 30 D08A 0350	N300116			1	1	PC30UD69V350A
	6,9 URD 30 D08A 0400	P300117			1	1	PC30UD69V400A
	6,9 URD 30 D08A 0450	A300403			0,95	1	PC30UD69V450A
	6,9 URD 30 D08A 0500	B300404			0,95	1	PC30UD69V500A
	6,9 URD 30 D08A 0550	C300405			0,95	1	PC30UD69V550A
	31	6,9 URD 31 D08A 0160	M300322			430	1
6,9 URD 31 D08A 0200		Y300010		1	1		PC31UD69V200A
6,9 URD 31 D08A 0250		Z300011		1	1		PC31UD69V250A
6,9 URD 31 D08A 0315		A300012		1	1		PC31UD69V315A
6,9 URD 31 D08A 0350		Q300049		1	1		PC31UD69V350A
6,9 URD 31 D08A 0400		B300013		1	1		PC31UD69V400A
6,9 URD 31 D08A 0450		C300014		1	1		PC31UD69V450A
6,9 URD 31 D08A 0500		D300015		1	1		PC31UD69V500A
6,9 URD 31 D08A 0550		E300016		1	1		PC31UD69V550A
6,9 URD 31 D08A 0630		F300017		1	1		PC31UD69V630A
6,9 URD 31 D08A 0700		G300018		0,95	1		PC31UD69V700A
6,9 URD 31 D08A 0800		D300406		0,85	0,90		PC31UD69V800A
32	6,9 URD 32 D08A 0315	H302158		590	1	1	PC32UD69V315A
	6,9 URD 32 D08A 0350	K302160			1	1	PC32UD69V350A
	6,9 URD 32 D08A 0400	E300177			1	1	PC32UD69V400A
	6,9 URD 32 D08A 0450	F300178			1	1	PC32UD69V450A
	6,9 URD 32 D08A 0500	G300179			1	1	PC32UD69V500A
	6,9 URD 32 D08A 0550	H300180			0,95	1	PC32UD69V550A
	6,9 URD 32 D08A 0630	J300181			0,95	1	PC32UD69V630A
	6,9 URD 32 D08A 0700	K300182			0,90	1	PC32UD69V700A
	6,9 URD 32 D08A 0800	L300183			0,90	0,95	PC32UD69V800A
	6,9 URD 32 D08A 0900	M300184			0,90	0,95	PC32UD69V900A
	6,9 URD 32 D08A 1000	N300185			0,85	0,95	PC32UD69V1000A
	6 URD 32 D08A 1100	W302101			0,80	0,85	PC32UD60V1100A
5 URD 32 D08A 1250	G300409		0,80	0,85	PC32UD50V1250A		
33	6,9 URD 33 D08A 0450	T302168		860	0,95	1	PC33UD69V450A
	6,9 URD 33 D08A 0500	G300248			0,95	1	PC33UD69V500A
	6,9 URD 33 D08A 0550	H300249			0,90	1	PC33UD69V550A
	6,9 URD 33 D08A 0630	J300250			0,90	0,95	PC33UD69V630A
	6,9 URD 33 D08A 0700	K300251			0,90	0,95	PC33UD69V700A
	6,9 URD 33 D08A 0800	L300252			0,85	0,95	PC33UD69V800A
	6,9 URD 33 D08A 0900	M300253			0,85	0,95	PC33UD69V900A
	6,9 URD 33 D08A 1000	N300254			0,80	0,90	PC33UD69V1000A
	6,9 URD 33 D08A 1100	P300255			0,80	0,90	PC33UD69V1100A
	6,9 URD 33 D08A 1250	Q300256			0,75	0,85	PC33UD69V1250A
	6,9 URD 33 D08A 1400	R300257			0,75	0,80	PC33UD69V1400A
	6 URD 33 D08A 1600	X301803			0,70	0,75	PC33UD60V1600A

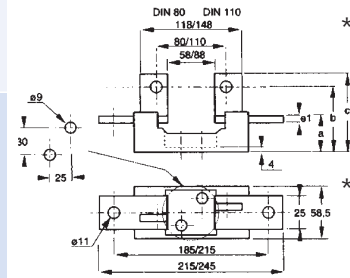
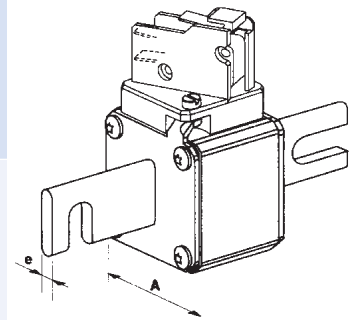
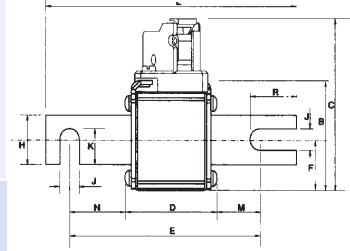

Fuse holders and microswitches supplied separately (see page , and Fuse Blocks and Fuse Holders section)

Dimensions in mm

Fuse Size	A	B	C	D	E	F	G	H	J	K	d	e	L	M
30 DIN 80	40	46,5	82	47,5	77	21	25	10,5	17,7	110	11,5	18,5	25,2	6
31 DIN 80	51	56,5	91	47,5	77	25,5	25	10,5	17,7	110	11,5	18,5	25,2	6
32 DIN 80	60	65,5	100	47,5	77	30	32	10,5	21,2	110	11,5	18,5	25,2	6
33 DIN 80	74,5	79,5	114	48,5	77	37,2	40	10,5	25,2	110	11	18	25,2	6

Fuse holders	Ref. Number	a	b	c	e1	x	y	Weight (g) *
SI DIN 80 630 A	L098772	40	68	82	5	185	215	660
SI DIN 80 1250 A	F098560	45	73	87	10	185	215	890

Use the pullout grip PM3 (T097675) for fuse sizes 30, 31, 32

Semiconductor (AC) fuses

Protistor® Square-body Fuses PSC aR sizes 3x - 450V to 700 VAC IEC Terminals German - 30 - 33 Blades (Din110)

Size	Designation	Reference Number		Weight (g)	I/IN Base		Catalog Number DIN 110
		DIN 110			L98772 F98031	F98560 L91941	
30	6,9 URD 30 D11A 0050	G301191		290	1	1	PC30UD69V50D1A
	6,9 URD 30 D11A 0063	Q300118			1	1	PC30UD69V63D1A
	6,9 URD 30 D11A 0080	R300119			1	1	PC30UD69V80D1A
	6,9 URD 30 D11A 0100	S300120			1	1	PC30UD69V100D1A
	6,9 URD 30 D11A 0125	T300121			1	1	PC30UD69V125D1A
	6,9 URD 30 D11A 0160	V300122			1	1	PC30UD69V160D1A
	6,9 URD 30 D11A 0200	W300123			1	1	PC30UD69V200D1A
	6,9 URD 30 D11A 0250	X300124			1	1	PC30UD69V250D1A
	6,9 URD 30 D11A 0315	Y300125			1	1	PC30UD69V315D1A
	6,9 URD 30 D11A 0350	Z300126			1	1	PC30UD69V350D1A
	6,9 URD 30 D11A 0400	A300127			1	1	PC30UD69V400D1A
	6,9 URD 30 D11A 0450	S300695			0,95	1	PC30UD69V450D1A
	6,9 URD 30 D11A 0500	Y301091			0,95	1	PC30UD69V500D1A
	6,9 URD 30 D11A 0550	Z301092			0,95	1	PC30UD69V550D1A
31	6,9 URD 31 D11A 0160	-		430	1	1	PC31UD69V200D1A
	6,9 URD 31 D11A 0200	H300019			1	1	PC31UD69V250D1A
	6,9 URD 31 D11A 0250	J300020			1	1	PC31UD69V315D1A
	6,9 URD 31 D11A 0315	K300021			1	1	PC31UD69V350D1A
	6,9 URD 31 D11A 0350	P300048			1	1	PC31UD69V400D1A
	6,9 URD 31 D11A 0400	L300022			1	1	PC31UD69V450D1A
	6,9 URD 31 D11A 0450	M300023			1	1	PC31UD69V500D1A
	6,9 URD 31 D11A 0500	N300024			1	1	PC31UD69V550D1A
	6,9 URD 31 D11A 0550	P300025			1	1	PC31UD69V630D1A
	6,9 URD 31 D11A 0630	Q300026			1	1	PC31UD69V700D1A
	6,9 URD 31 D11A 0700	R300027			0,95	1	PC31UD69V800D1A
	6,9 URD 31 D11A 0800	H300079			0,85	0,90	PC31UD69V800D1A
32	6,9 URD 32 D11A 0315	K302160		590	1	1	PC32UD69V350D1A
	6,9 URD 32 D11A 0350	L302161			1	1	PC32UD69V400D1A
	6,9 URD 32 D11A 0400	P300186			1	1	PC32UD69V450D1A
	6,9 URD 32 D11A 0450	Q300187			1	1	PC32UD69V500D1A
	6,9 URD 32 D11A 0500	R300188			1	1	PC32UD69V550D1A
	6,9 URD 32 D11A 0550	S300189			0,95	1	PC32UD69V630D1A
	6,9 URD 32 D11A 0630	T300190			0,95	1	PC32UD69V700D1A
	6,9 URD 32 D11A 0700	V300191			0,90	1	PC32UD69V800D1A
	6,9 URD 32 D11A 0800	W300192			0,90	0,95	PC32UD69V800D1A
	6,9 URD 32 D11A 0900	X300193			0,90	0,95	PC32UD69V900D1A
	6,9 URD 32 D11A 1000	Y300194			0,85	0,95	PC32UD69V10CD1A
	6 URD 32 D11A 1100	-			0,80	0,85	
5 URD 32 D11A 1250	-		0,80	0,85			
33	6,9 URD 33 D11A 0450	V302169		860	0,95	1	PC33UD69V450D1A
	6,9 URD 33 D11A 0500	S300258			0,95	1	PC33UD69V500D1A
	6,9 URD 33 D11A 0550	T300259			0,90	1	PC33UD69V550D1A
	6,9 URD 33 D11A 0630	V300260			0,90	0,95	PC33UD69V630D1A
	6,9 URD 33 D11A 0700	W300261			0,90	0,95	PC33UD69V700D1A
	6,9 URD 33 D11A 0800	X300262			0,85	0,95	PC33UD69V800D1A
	6,9 URD 33 D11A 0900	Y300263			0,85	0,95	PC33UD69V900D1A
	6,9 URD 33 D11A 1000	Z300264			0,80	0,90	PC33UD69V10CD1A
	6,9 URD 33 D11A 1100	A300265			0,80	0,90	PC33UD69V11CD1A
	6,9 URD 33 D11A 1250	B300266			0,75	0,85	PC33UD69V12CD1A
	6,9 URD 33 D11A 1400	C300267			0,75	0,80	PC33UD69V14CD1A
	6 URD 33 D11A 1600	Z301437			0,70	0,75	PC33UD60V16CD1A

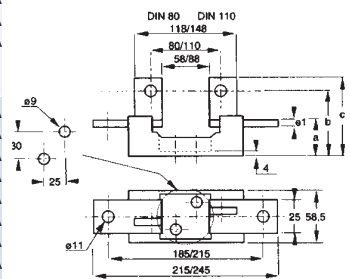
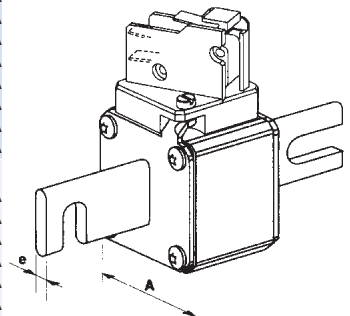
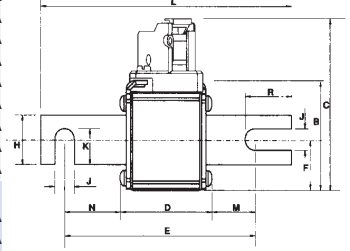

Fuse holders and microswitches supplied separately (see Fuse Holders and microswitches 3x & 7x sections)

Dimensions in mm

fuse Size	A	B	C	D	E	F	G	H	J	K	d	e	L	M
30 DIN 110	40	46,5	82	47,5	101,6	21	25	10,5	17,7	134,6	23,8	30,8	25,2	6
31 DIN 110	51	56,5	91	47,5	101,6	25,5	25	10,5	17,7	134,6	23,8	30,8	25,2	6
32 DIN 110	60	65,5	100	47,5	101,6	30	32	10,5	21,2	134,6	23,8	30,8	25,2	6
33 DIN 110	74,5	79,5	114	48,5	101,6	37,2	40	10,5	25,2	134,6	23,3	30,3	25,2	6

Fuse holders	Ref. Number	a	b	c	e1	x	y	Weight (g)
SI DIN 110 630 A	F098031	40	68	82	5	215	245	1060
SI DIN 110 1250 A	L091941	45	73	87	10	215	245	1320

Use the pullout grip PM3 (T097675) for fuse sizes 30, 31, 32



Semiconductor (AC) fuses

Protistor® Square-body Fuses PSC aR sizes 3x - 450V to 700 VAC Curves set

Sizes 30 - 31 - 32 - 33

I²t Multiplier coefficient

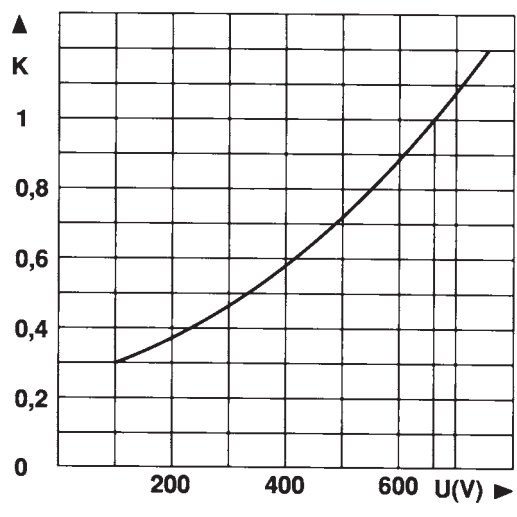

Mean curve indicating variation of total I²t (I²t_t) and total operating time T_t in accordance with working voltage U.

Example:

Fuse 350 A in size 30.
I_p = 10 000 A U = 500 V

At 660 V
I²t_t = 80 000 A²s T_t = 6 ms

At 500 V
I²t_t = 80 000 x 0.72 = 57 600 A²s
T_t = 6 x 0.72 = 4.3 ms

Dissipated power

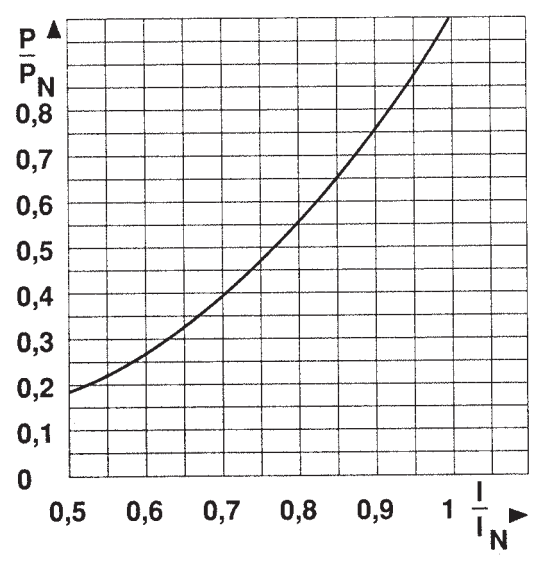

Curve enabling calculation of dissipated power P by a fuse rated I_N, as a function of the RMS current I, in multiples of I_N, in a steady state.

Arc voltage

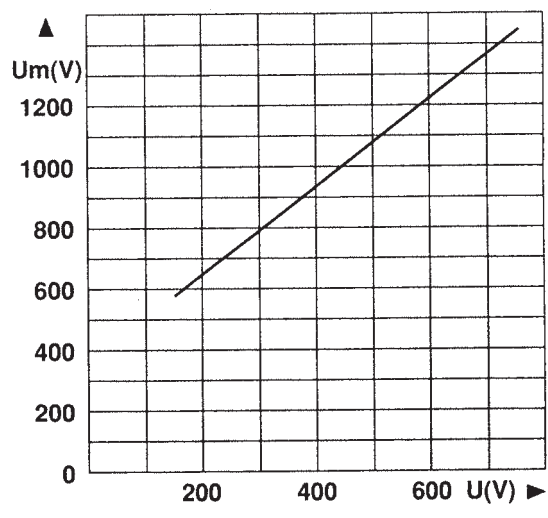

Curve indicating peak arc voltage U_m which may appear across fuse terminals as function of working voltage U at cos φ = 0.15



Protistor® Square-body Fuses PSC aR sizes 3x - 450V to 700 VAC Curves set

Size 30

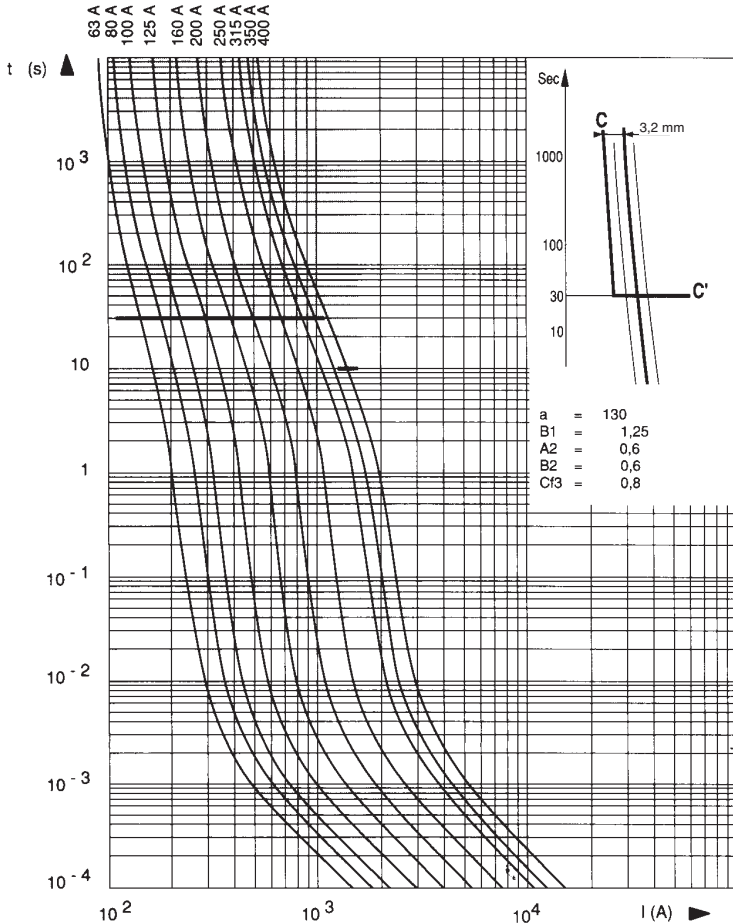

↓ Cut-off characteristics

Below, right: Curves indicating for each rated-current the peak value I_C that the current may reach as a function of the prospective fault current I_p .

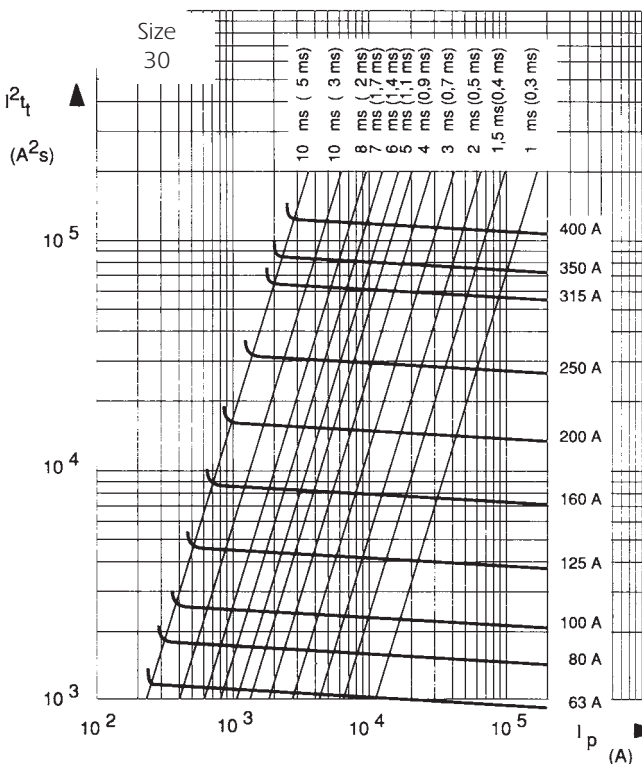
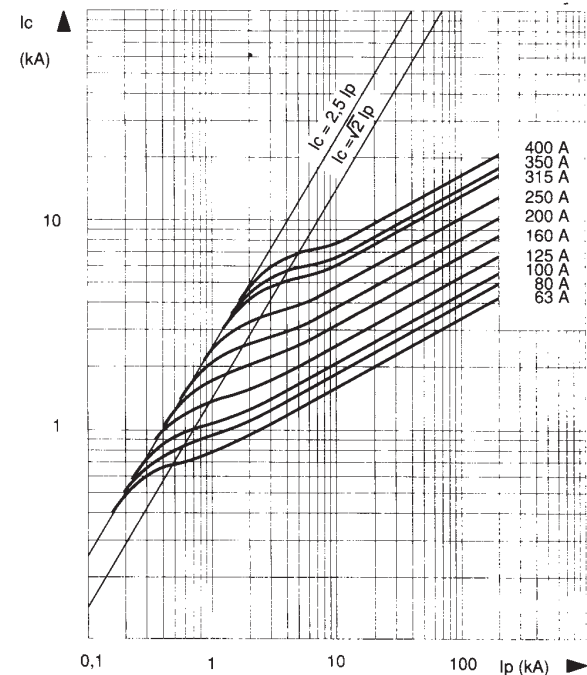

↑ Time-current characteristics

Above, left: Curves indicating pre-arcing time for each rated current as a function of RMS value of pre-arcing current I .

- Tolerances on this current $\pm 8\%$.
- Beyond 30 sec or 10 sec, small overloads must be eliminated by another device.
- Curve CC' represents the maximum times taken by the associated device to clear small overloads; only its horizontal line is represented. Its oblique line must be plotted according to sketch, top right corner.
- The intersection of the fuse and CC' curves indicates the minimum breaking current I_{pm} of the fuse.

← Maximum values of total operating I^2t and total operating times

Left: Horizontal curves indicating the maximum values of total operating I^2t (I^2t_t) as function of the prospective current I_p at 660 V, $\cos \varphi = 0.15$. The oblique lines indicate the corresponding total operating time T_T , with pre-arcing time in brackets.

Protistor® Square-body Fuses PSC aR sizes 3x - 450V to 700 VAC Curves set

Size 31

↓ Cut-off characteristics

Below, right: Curves indicating for each rated current the peak value I_C that the current may reach as a function of the prospective fault current I_P .

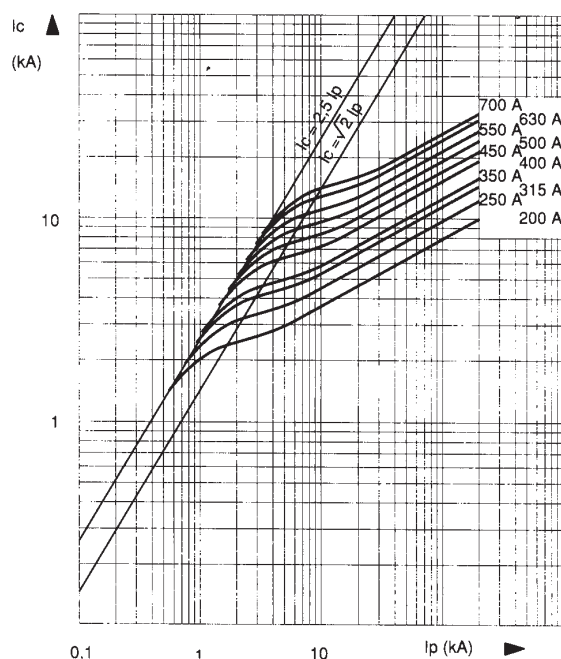
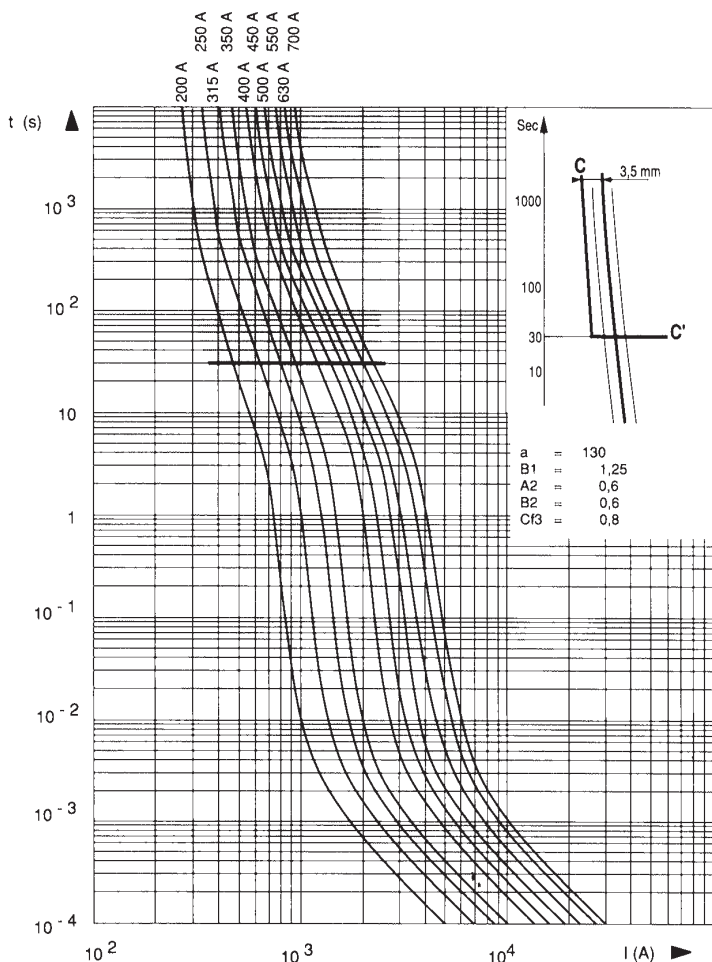

↑ Time-current characteristics

Above, left: Curves indicating pre-arcing time for each rated current as a function of RMS value of pre-arcing current I .

- Tolerances on this current $\pm 8\%$.
- Beyond 30 sec or 10 sec, small overloads must be eliminated by another device.
- Curve CC' represents the maximum times taken by the associated device to clear small overloads; only its horizontal line is represented. Its oblique line must be plotted according to sketch, top right corner.
- The intersection of the fuse and CC' curves indicates the minimum breaking current I_{pm} of the fuse.

← Maximum values of total operating I^2t and total operating times

Left: Horizontal curves indicating the maximum values of total operating I^2t (I^2t_t) as function of the prospective current I_P at 660 V, $\cos \varphi = 0.15$. The oblique lines indicate the corresponding total operating time T_T , with pre-arcing time in brackets.

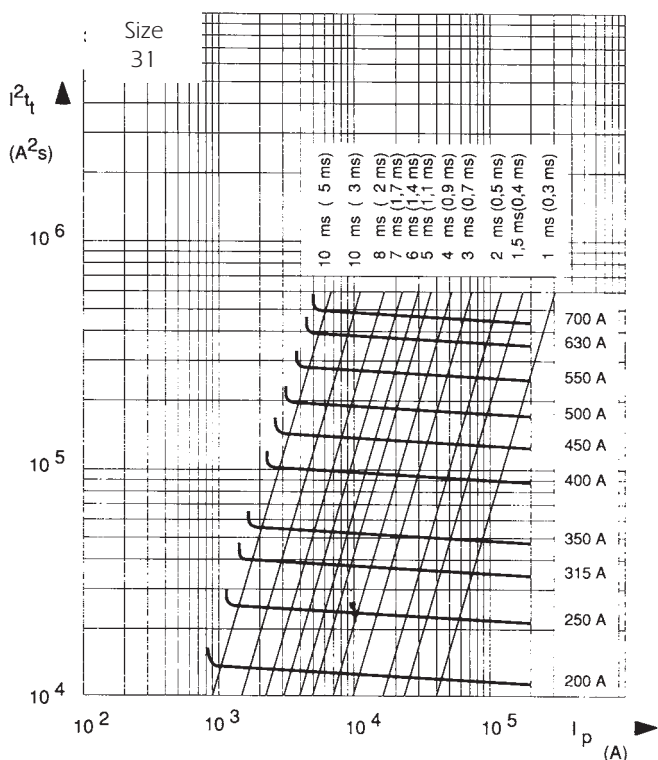



Protistor® Square-body Fuses PSC aR sizes 3x - 450V to 700 VAC Curves set

Size 32

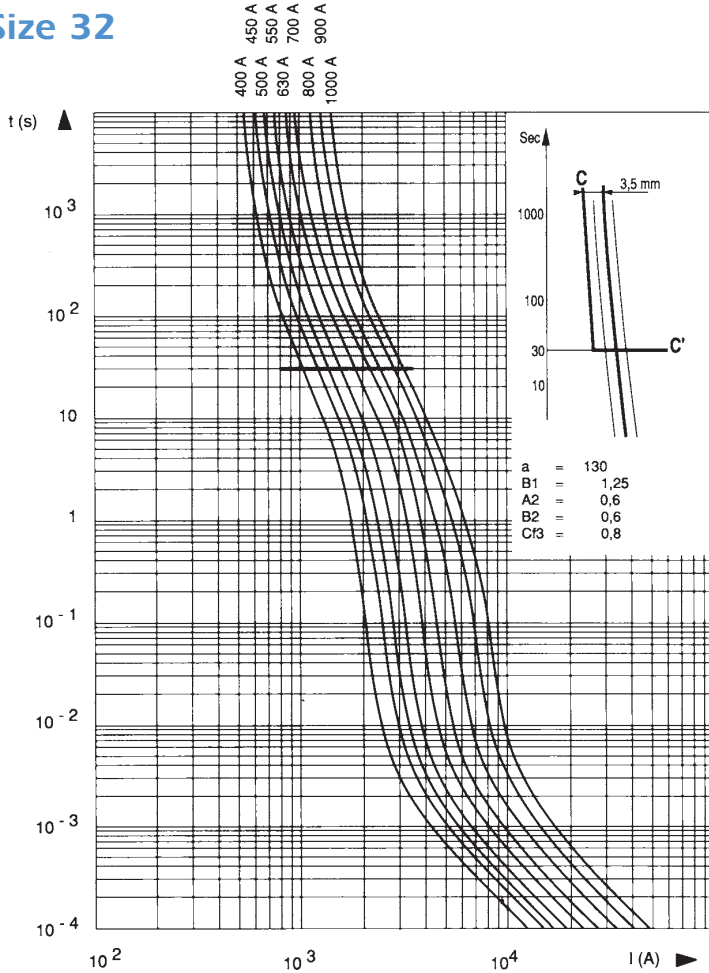

↓ Cut-off characteristics

Below, right: Curves indicating for each rated-current the peak value I_C that the current may reach as a function of the prospective fault current I_p .

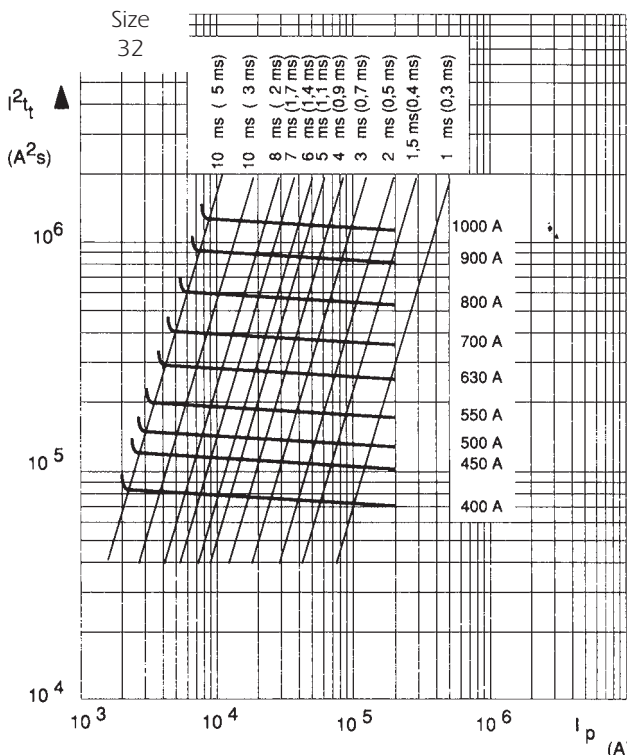
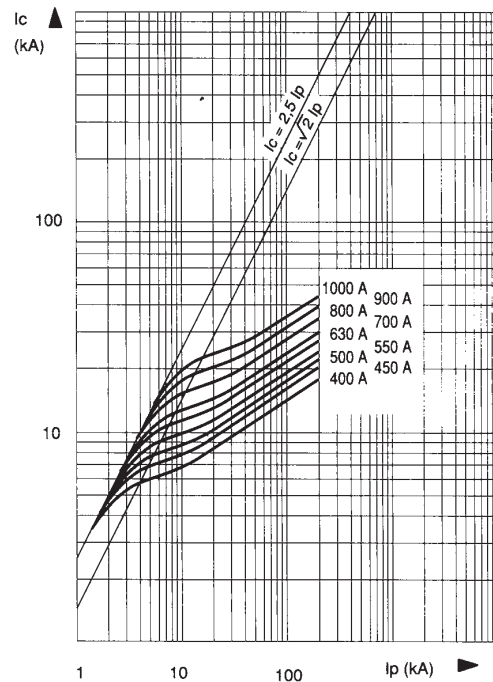

↑ Time-current characteristics

Above, left: Curves indicating pre-arcing time for each rated current as a function of RMS value of pre-arcing current I .

- Tolerances on this current $\pm 8\%$.
- Beyond 30 sec or 10 sec, small overloads must be eliminated by another device.
- Curve CC' represents the maximum times taken by the associated device to clear small overloads; only its horizontal line is represented. Its oblique line must be plotted according to sketch, top right corner.
- The intersection of the fuse and CC' curves indicates the minimum breaking current I_{pm} of the fuse.

← Maximum values of total operating I^2t and total operating times

Left: Horizontal curves indicating the maximum values of total operating I^2t (I^2t_t) as function of the prospective current I_p at 660 V, $\cos \varphi = 0.15$. The oblique lines indicate the corresponding total operating time T_t , with pre-arcing time in brackets.

Protistor® Square-body Fuses PSC aR sizes 3x - 450V to 700 VAC Curves set

Size 33

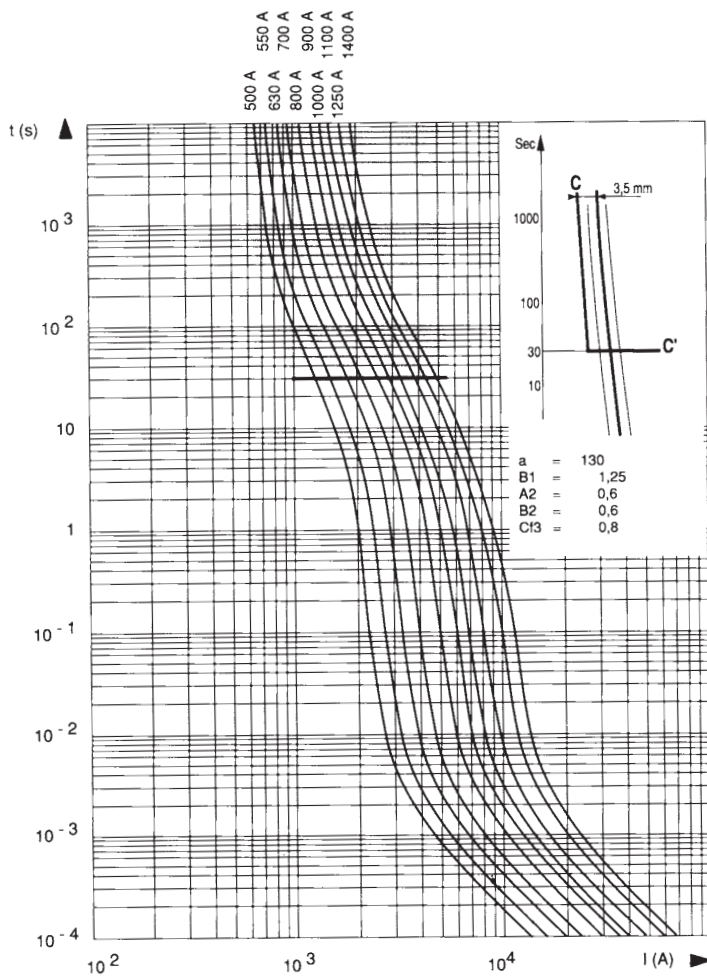

↓ Cut-off characteristics

Below, right: Curves indicating for each rated current the peak value I_C that the current may reach as a function of the prospective fault current I_p .

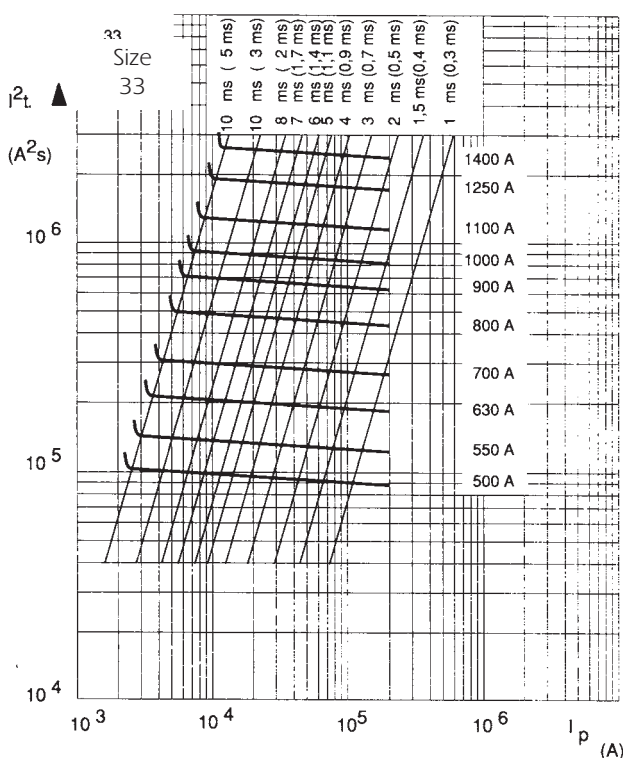
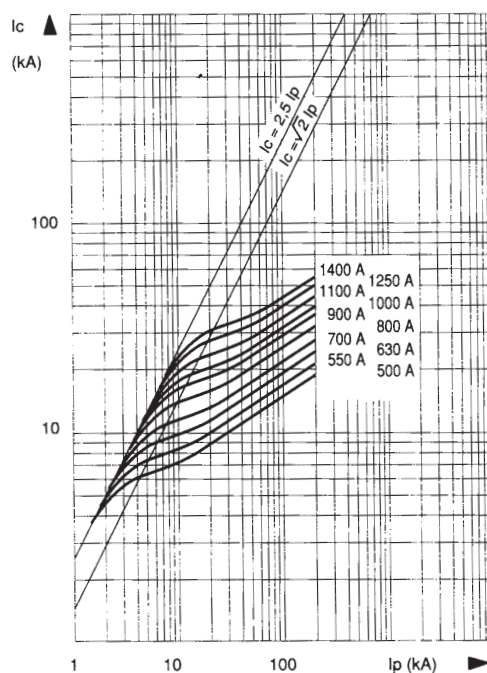

↑ Time-current characteristics

Above, left: Curves indicating pre-arcing time for each rated current as a function of RMS value of pre-arcing current I .

- Tolerances on this current $\pm 8\%$.
- Beyond 30 sec or 10 sec, small overloads must be eliminated by another device.
- Curve CC' represents the maximum times taken by the associated device to clear small overloads; only its horizontal line is represented. Its oblique line must be plotted according to sketch, top right corner.
- The intersection of the fuse and CC' curves indicates the minimum breaking current I_{pm} of the fuse.

← Maximum values of total operating I^2t and total operating times

Left: Horizontal curves indicating the maximum values of total operating I^2t (I^2t_t) as function of the prospective current I_p at 660 V, $\cos \varphi = 0.15$. The oblique lines indicate the corresponding total operating time T_t , with pre-arcing time in brackets.



Protistor® Square-body Fuses PSC aR sizes 3x - 450V to 700 VAC Curves set

Sizes 2x32

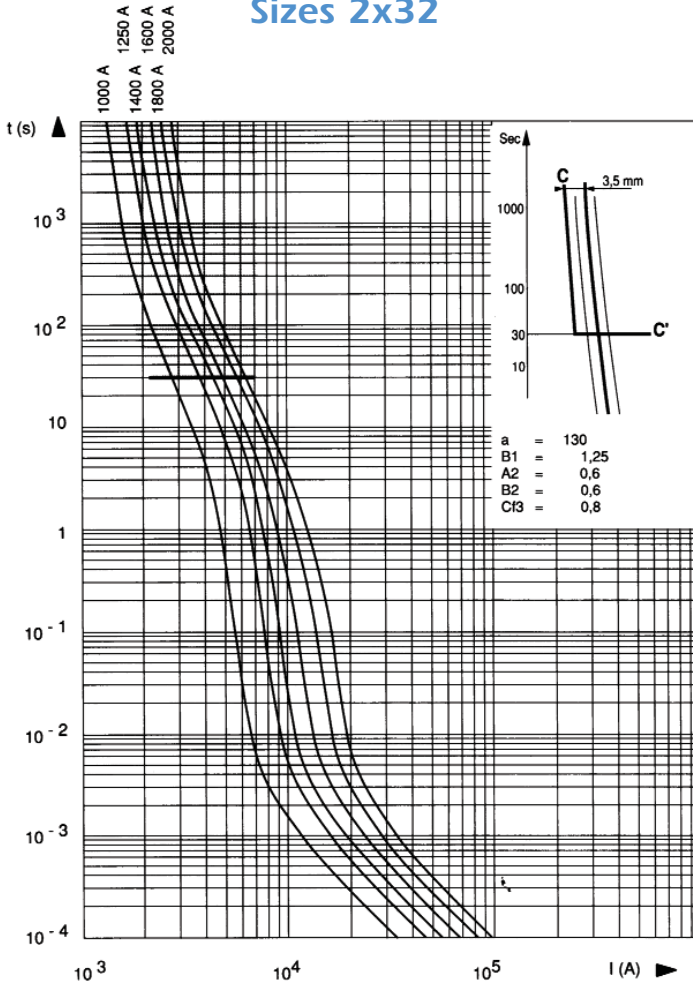

↓ Cut-off characteristics

Below, right: Curves indicating for each rated-current the peak value I_C that the current may reach as a function of the prospective fault current I_p .

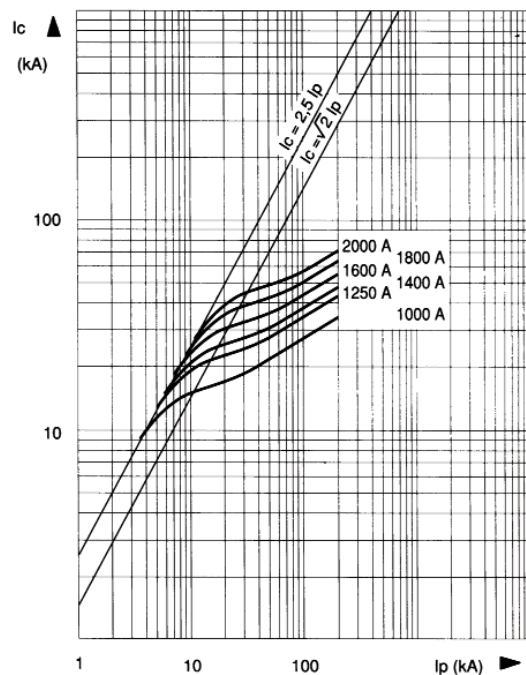

↑ Time-current characteristics

Above, left: Curves indicating pre-arcing time for each rated current as a function of RMS value of pre-arcing current I .

- Tolerances on this current $\pm 8\%$.
- Beyond 30 sec or 10 sec, small overloads must be eliminated by another device.
- Curve CC' represents the maximum times taken by the associated device to clear small overloads; only its horizontal line is represented. Its oblique line must be plotted according to sketch, top right corner.
- The intersection of the fuse and CC' curves indicates the minimum breaking current I_{pm} of the fuse.

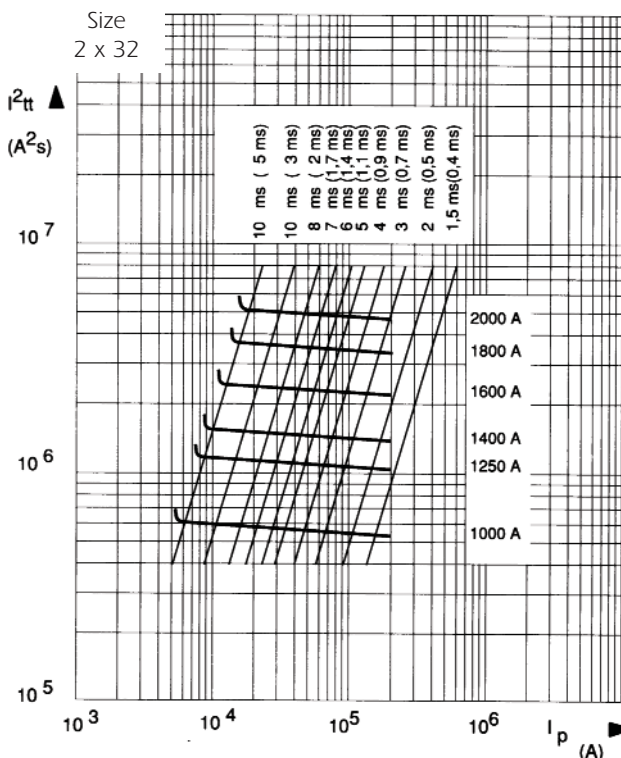

← Maximum values of total operating I^2t and total operating times

Left: Horizontal curves indicating the maximum values of total operating I^2t (I^2t_t) as function of the prospective current I_p at 660 V, $\cos \varphi = 0.15$. The oblique lines indicate the corresponding total operating time T_t , with pre-arcing time in brackets.

Protistor® Square-body Fuses PSC aR sizes 3x - 450V to 700 VAC Curves set

Size 2x33

↓ Cut-off characteristics

Below, right: Curves indicating for each rated current the peak value I_C that the current may reach as a function of the prospective fault current I_p .

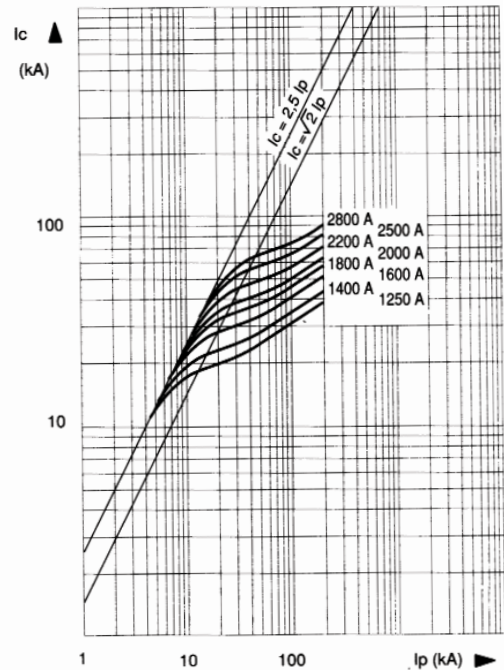
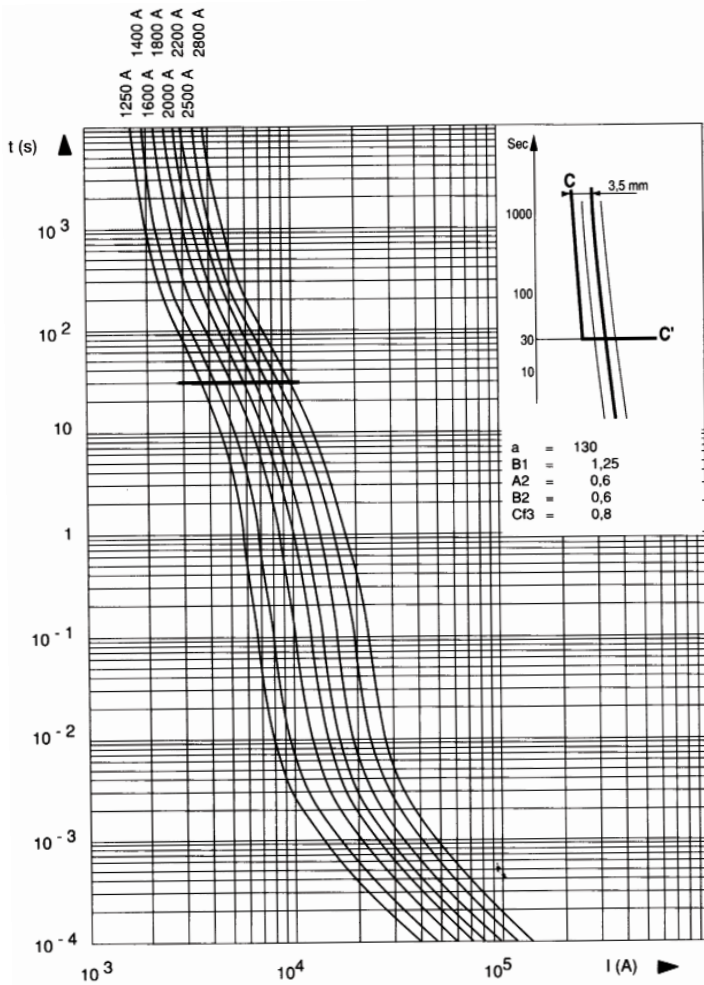

↑ Time-current characteristics

Above, left: Curves indicating pre-arcing time for each rated current as a function of RMS value of pre-arcing current I .

- Tolerances on this current $\pm 8\%$.
- Beyond 30 sec or 10 sec, small overloads must be eliminated by another device.
- Curve CC' represents the maximum times taken by the associated device to clear small overloads; only its horizontal line is represented. Its oblique line must be plotted according to sketch, top right corner.
- The intersection of the fuse and CC' curves indicates the minimum breaking current I_{pm} of the fuse.

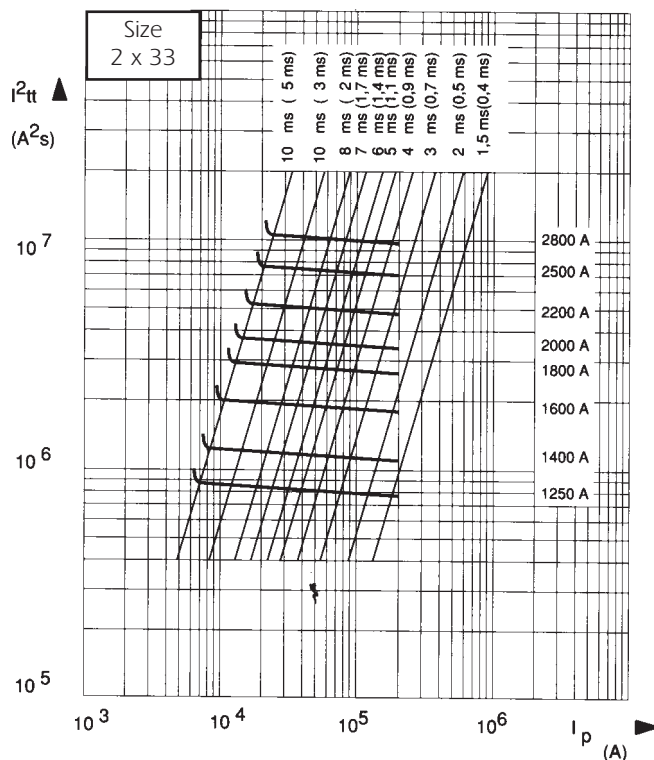

← Maximum values of total operating I^2t and total operating times

Left: Horizontal curves indicating the maximum values of total operating I^2t (I^2t_t) as function of the prospective current I_p at 660 V, $\cos \varphi = 0.15$. The oblique lines indicate the corresponding total operating time T_t , with pre-arcing time in brackets.



Protistor® Square-body Fuses PSC aR sizes 3x - 450V to 700 VAC Curves set

Sizes 30 - 31 - 32 - 33

DC working voltage possibilities

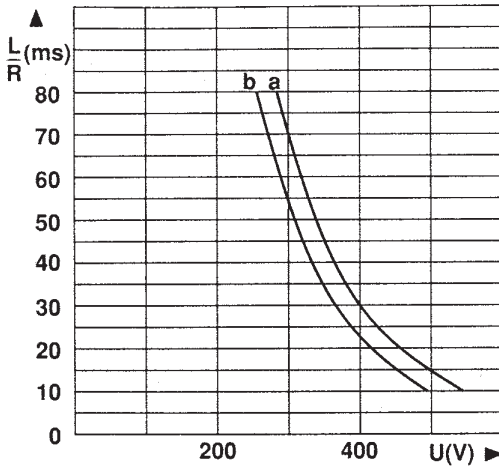

Rated current In (A)	Curves (*) and Ipm (I) corresponding to the rating					
	30 * Ipm (A)	31 * Ipm (A)	32 * Ipm (A)	33 * Ipm (A)	2 x 32 * Ipm (A)	2 x 33 * Ipm (A)
63	a 230					
80	a 300					
100	a 360					
125	a 460					
160	a 650					
200	a 880	a 850				
250	a 1300	a 1150				
315	a 1700	a 1450				
350	a 1900	a 1600				
400	a 2300	a 2200	a 2000			
450		a 2500	a 2300			
500		a 3000	a 2600	a 2300		
550		a 3400	a 3150	a 2500		
630		a 5000	a 3700	a 3250		
700		a 5600	a 4300	a 3900		
800			a 5300	a 4800		
900			a 7800	a 5600		
1000			b 9000	a 6600	a 5200	
1100				a 7700		
1250				b 11000	a 7400	a 6500
1400				b 12500	a 8600	a 7800
1600					a 10600	a 9600
1800					a 15600	a 11200
2000					b 18000	a 13200
2200						a 15400
2500						b 22000
2800						b 25000

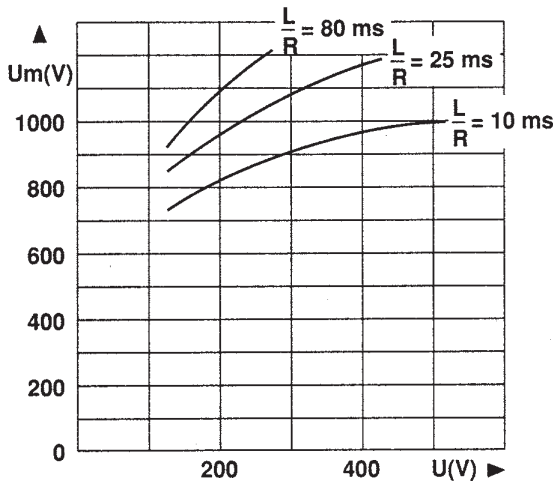

Top: Curves indicating the maximum time constant L/R of the fault path as a function of the DC voltage U for the rated currents in the sizes indicated in the table.

Ipm (I) values indicate the minimum breaking current in Amperes (A).

Remark:

When the fault current di/dt is very large, this condition can be exceeded. This is the case for faults occurring in voltage commutated inverters.

Below: Curves indicating peak arc voltage U_m which may appear across fuse terminals as a function of the DC working voltage U , for various time constant L/R of fault path.

Protistor® Square-body Fuses PSC aR sizes 3x - 450V to 700 VAC Microswitches PSC 3x & 7x

- MICROSWITCH SYSTEMS ADAPTED

TO THE FOLLOWING FERRAZ SHAWMUT FUSES ONLY:

- PSC sizes 30, 31, 32, 33, 2x32, 2x33 / 70, 71, 72, 73, 272, 273
except plain blades

- PSC LR sizes 33, 233, 73, 273

- PERMANENT INDICATION OF FUSE STATE: CONDUCTIVE
BLOWN

- MANUAL RESETTING

- STANDARD AND LOW ELECTRICAL LEVEL WITH DIFFERENT INSULATION LEVELS

- BS TYPE FOR USE IN CORROSIVE ATMOSPHERE

- MS 3V 1-5 UR AND MS 7V 1-5 UR TYPE UL ARE RECOGNIZED



MS 7V 1-5

Main Characteristics

Code	AC Insulation voltage rating (***)	Positive operating voltage/current	Current rating	Current	Breaking Capacity						AC voltage withstand test (*)	Impulse voltage test Uimp1.2/50 µs (**)	Fire class according to UL 94
					Non inductive circuit			Inductive circuit : L/R = 25ms					
					30V	110V	250V	30V	110V	250V			
MS 3V 1-5	1000 V	20 V 50 mA	10 A	50/60 Hz	10 A	10 A	10 A	10 A	10 A	10 A	8,5 kV	14 kV	H.B
MS 3V 1-5 UR				DC	8 A	0,4 A	0,2 A	4 A	0,2 A	0,1 A			
MS 7V 1-5	1500V	10 V 10 mA	3 A	50/60 Hz	3 A	3 A	3 A	2 A	1 A	1 A	8,5 kV	14 kV	
MS 7V 1-5 UR				DC	3 A	0,5 A	0,25 A	3 A	0,2 A	0,1 A			
MS 3V 1-5 BS	1000 V	10 V 10 mA	3 A	50/60 Hz	3 A	3 A	3 A	2 A	1 A	1 A	8,5 kV	14 kV	
MS 3V 1-9 BS				DC	3 A	0,5 A	0,25 A	3 A	0,2 A	0,1 A			
MS 7V 1-5 BS	1500V	10 V 10 mA	3 A	50/60 Hz	3 A	3 A	3 A	2 A	1 A	1 A	8,5 kV	14 kV	
MS 7V 1-9 BS				DC	3 A	0,5 A	-	2 A	0,2 A	-			
MS 3V 1-5 ET	1000V	10 V	3 A	50/60 Hz	3 A	3 A	3 A	2 A	1 A	1 A	8,5 kV	14 kV	
MS 7V 1-5 ET	1500V	10 mA	3 A	DC	3 A	0,5 A	-	2 A	0,2 A	-	12 kV	20 kV	

* Between power circuit and microswitch terminals as per IEC 60 and 694 and NFC 64010 (50/60 Hz 1 min duration in dry air)

** Between power circuit and microswitch terminals Uimp: impulse voltage as per IEC 60947-1

*** Between power circuit and microswitch terminals

Warning: microswitch systems exclusively designed for FERRAZ SHAWMUT.
PSC Fuses fitted a patented trip-indicator, saving use of EDV



Protistor® Square-body Fuses PSC aR sizes 3x - 450V to 700 VAC Microswitches for PSC 3x & 7x

Indication systems for PSC Fuse sizes 30 to 73 MS 3V...

These patented indication systems are exclusively hand resettable.

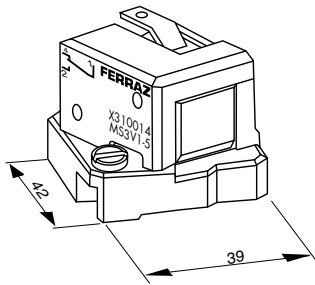

(fig. 1)

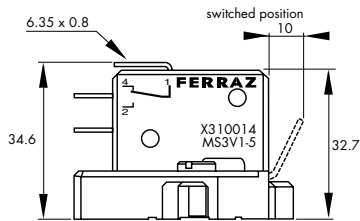

Fuse size	Designation	Ref. Number	Indication style	Weight (g)	Pack.	Catalog Number
30, 31 32, 33	MS 3V 1-5 (fig.1)	X310014	Standard NO-NC	34	3 pieces	MS3 V1-5
	MS 3V 1-5 UR	Y310038				MS3 V1-5UR
	MS 3V 1-5 BS (3)	K310013	Low level NO-NC	34	3 pieces	MS3-V1-5BS
	MS 3V 1-9 BS (4)	P310011	Double pole Low level	44	3 pieces	MS3V1-9BS
	MS 3V 1-5 ET (fig.2)	S310009	Low level NO-NC IP 50 (9)	34	3 pieces	MS3V1-5 ETANCHE

(3) Same as fig.1

(4) Same dimensions as figure 1 but with 2 microswitches side by side

(9) Watertightness class

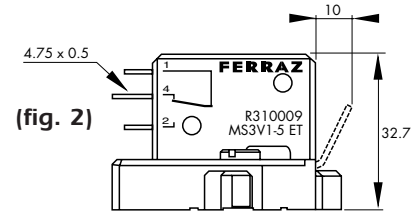

(fig. 2)

MS 7V...

Fuse size	Designation	Ref. Number	Indication style	Weight (g)	Pack.	Catalog Number
70, 71 72, 73	MS 7V 1-5 (fig.5)	J310002	Standard NO-NC	45	3 pieces	MS7 V1-5
	MS 7V 1-5 UR	Z310039				MS7 V1-5UR
	MS 7V 1-5 BS (3)	K310003	Low level NO-NC	45	3 pieces	MS7-V1-5BS
	MS 7V 1-9 BS (4)	P310007	Double pole Low level	55	3 pieces	MS7V1-9BS
	MS 7V 1-5 ET (fig.6)	S310010	Low level NO-NC IP 50 (9)	55	3 pieces	MS7V1-5 ETANCHE

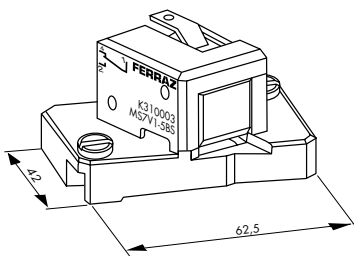

(fig. 5)

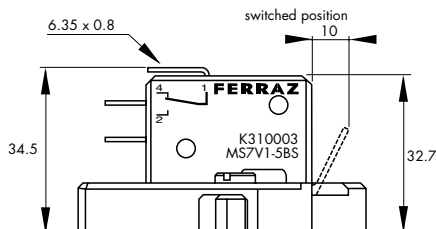

(7) Same as fig. 5

(8) Same dimensions as figure 5 but with 2 microswitches side by side

(9) Watertightness class

Warning: Microswitch systems exclusively designed for FERRAZ SHAWMUT PSC fuses fitted with a patented trip-indicator, saving use of EDV.

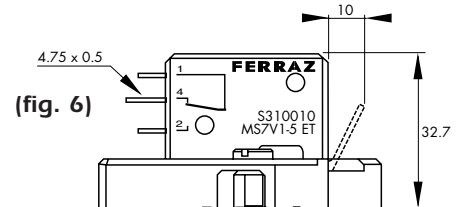



(fig. 6)

Protistor® Square-body Fuses PSC aR sizes 3x - 450V to 700 VAC Metric-studs

Metric studs for threaded terminal fuses



Type and fuse size	Designation	Ref. Number	Unit weight (g)	Pack.	Catalog Number
 Sizes 0 and 1 Size 2 Size 3	HC stud pair M8x30 & M8x35	S098801	23	6 pairs	STUM8x30M8x35
	HC stud pair M10x30 & M10x50	T098802	40	6 pairs	STUM10x30M10x50
	HC stud pair M12x35 & M12x50	V098803	60	6 pairs	STUM12x35M12x50
 Size 2 Size 3	HC stud pair M10x50	W098804	45	6 pairs	STUM10x50
	HC stud pair M12x50	X098805	45	6 pairs	STUM12x50

We recommend the use of studs, whose quality is suited to all FERRAZ SHAWMUT square-body fuses with terminals

Stud mounting

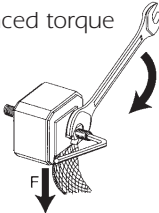
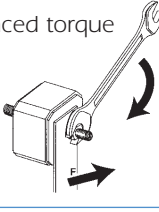
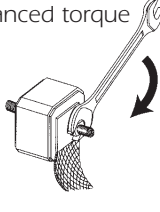
Torque type	Stud type	Maximum stud tightning torque (Nm) (1)	Maximum nut tightning torque (Nm) (1)
Balanced torque 	M8x30 & M8x35	10	13.5
	M10x30 & M10x50	15	26
	M12x35 & M12x50	15	46
Balanced torque 	M8x30 & M8x35	10	13.5
	M10x30 & M10x50	15	26
	M12x35 & M12x50	15	46
Unbalanced torque 	M8x30 & M8x35	10	13.5
	M10x30 & M10x50	15	26
	M12x35 & M12x50	15	46