

## Protistor® Square-body Fuses PSC aR sizes 7x - 650 V to 1300 VAC Main characteristics

 Recognized

### 650 to 1300VAC / 63 to 2800A.

- Exceptionally low I<sup>2</sup>T, Watt losses.
- Non-magnetic construction, highly reliable low voltage.
- Indicator system.
- Conformity to UL, CSA investigated, IEC, DIN and VDE standards.
- Increased technical performance
- Higher ratings.
- Reduction in volume and weight.
- This fuse preselection table indicates, for each size:
  - rated current (or rating) I<sub>n</sub>
  - pre-arcing I<sup>2</sup>t (I<sup>2</sup>t<sub>p</sub>) at 1 ms
  - total operating I<sup>2</sup>t (I<sup>2</sup>t<sub>t</sub>) at 1000 V and 850V(I)f=50Hz, cos φ =0.15, and for a total operating time from 8 to 10 ms
  - dissipated power P<sub>n</sub> at the rated current I<sub>n</sub>, and at 0.8 I<sub>n</sub>, in steady state
  - breaking capacity at various voltages, checked by tests made in accordance with IEC and American standards.



Estimated breaking capacity: 300 kA

### PSC 650 to 1300VAC US and European standard

Size	Nominal Voltage U <sub>N</sub> (VAC)		Ampere Rating (A)	Pre-arcing I <sup>2</sup> t @ 1ms (kA <sup>2</sup> s)	Total I <sup>2</sup> t @ 1000V (*) @ U <sub>n</sub> (kA <sup>2</sup> s)	Power (W)		Tested Breaking capacity				
	IEC	UL				End contacts	Blades	IEC	USA			
70	1250	1300	50	0,116	0,7	16	16	100kA @ 1250V	100kA @ 1300V			
			63	0,210	1,2	26	26					
			80	0,470	2,7	27	27					
			100	0,830	4,8	30	30					
			125	1,30	7,5	38	38					
			160	2,55	15	45	45					
	1200	1300	200	4,7	27	54	56	100kA @ 1200V	100kA @ 1300V			
			250	9,6	55	58	61					
			280	14	82	61	64					
			315	20	115	66	72					
			350	28	158	68	75					
			400	39	224	81	90					
1100	1200	450	62	356	82	82	150kA @ 1100V	150kA @ 1200V				
		500	84	483	83	83						
		800	900	550	128	576(*)			83	83	120kA @ 1000V	120kA @ 1100V
750	800	550	128	576(*)	83	83	100kA @ 800V	100kA @ 900V				
		630	176	730(*)	91	91	100kA @ 750V	100kA @ 800V				
		160	2,6	15	46	46	100kA @ 1250V	100kA @ 1300V				
1250	1300	200	4,7	27	54	54						
		250	8,9	51	61	61						
		280	12	68	68	70						
		315	16	92	73	76						
		350	22	127	76	80						
		400	38	220	76	80						
		450	47	270	87	95						
		1100	1300 (TTI)	500	68	390			90	X	150kA @ 1100V	150kA @ 1200V
				500	68	390			X	100		
				550	84	485			98	112		
		1000	1100	630	125	725			105	X	150kA @ 1000V	150kA @ 1100V
				630	125	725	X	120				
700	180			1040	105	105						
900	950	800	290	1540(*)	116	116	100kA @ 900V	100kA @ 950V				
		800	850	900	446	2010(*)	120	120	100kA @ 800V	100kA @ 850V		

(<sup>1</sup>) at 850 V

(<sup>2</sup>) does not exist with blades



## Protistor® Square-body Fuses PSC aR sizes 7x - 650 V to 1300 VAC Main characteristics

### PSC 650 to 1300VAC US and European standard

Size	Nominal Voltage U <sub>N</sub> (VAC)		Ampere Rating (A)	Pre-arcing I <sub>pt</sub> @ 1ms (kA <sub>2s</sub> )	Total I <sup>2</sup> t @ 1000V (*) @ U <sub>N</sub> (kA <sub>2s</sub> )	Power (W)		Tested Breaking capacity Estimated B.C 300 kA					
	IEC	UL				End contacts	Blades	IEC	USA				
72	1250	1300	280	10	60	72	72	100kA @ 1250V	100kA @ 1300V				
			315	15	87	76	76						
			350	21	120	77	77						
			400	32,5	190	80	80						
			450	44	255	87	89						
			500	57	330	94	98						
	550	68	390	110	120								
	630	105	610	113	X								
	1100	1200	630	105	610	X	125	150kA @ 1100V	150kA @ 1200V				
			700	145	815	122	140						
			800	215	1240	125	146						
	1000	1100	700	145	815	X	140	150kA @ 1000V	150kA @ 1100V				
800			215	1240	X	146							
900			312	1800	130	152							
850	900	1000	439	2150(*)	136	136	100kA @ 850V	100kA @ 900V					
73	1250	1300	315	12	68	84	84	100kA @ 1250V	100kA @ 1300V				
			350	17	100	86	86						
			375	19	110								
			400	25	145	93	93						
			450	35,5	205	99	100						
			500	44	255	110	112						
			550	57	330	116	120						
			630	84	485	125	132						
			700	110	640	135	X						
			800	190	1090	136	X						
			1200	1300	700	110	640			X	146	100kA @ 1200V	100kA @ 1300V
					900	250	1090			150	X		
	1100	1200			800	190	1090	X	148	150kA @ 1100V	150kA @ 1200V		
					900	250	1440	X	170	150kA @ 1000V	150kA @ 1100V		
	1000	1100			1000	370	2130	152	168				
					1100	445	2555	168	208				
	950	1000	1100	445	2430(*)	168	X	150kA @ 950V	150kA @ 1000V				
	900	1000	1000	370	1920(*)	X	174	150kA @ 900V	150kA @ 1000V				
			1100	445	2280(*)	X	208						
			1250	585	3080(*)	186	X						
			1400	755	4100(*)	210	X						
	850	900	1400	755	3700(*)	210	X	150kA @ 850V	150kA @ 900V				
	690	700	1500	1180	4750(*)	200	X	180kA @ 690V	180kA @ 700V				
			1600	1430	5740(*)	203	X						
600	650	1800	2040	7150(*)	206	X	120kA @ 600V	120kA @ 650V					
2 x 72	1250		630	60	348	160		100kA @ 1250V					
			700	84	480	162							
			800	130	760	168							
			900	176	1020	183							
			1000	228	1320	197							
			1100	272	1560	231							
	1100			1250	426	2440	237		100kA @ 1100V				
				1400	568	3260	256						
				1600	860	4895	262		100kA @ 1000V				
				1800	1250	6350(*)	275		100kA @ 900V				
				2000	1760	7570(*)	285		100kA @ 750V				
				2200	2410	8350(*)	320		100kA @ 650V				
2 x 73	1250		800	100	580	195		100kA @ 1250V					
			900	142	820	208							
			1000	176	1000	231							
			1100	228	1300	244							
			1250	336	1900	262							
			1400	440	2600	283							
	1100			1600	760	4400	286		100kA @ 1100V				
				1800	1000	5800	315						
				2000	1480	8500	319		120kA @ 1000V				
				2200	1780	9632(*)	353		100kA @ 950V				
				2500	2340	12075(*)	390		110kA @ 900V				
				2800	3000	15000(*)	440		100kA @ 850V				
600		3000	4980	15700(*)	405		200kA @ 600V						
		3200	5720	19030(*)	426								
		3600	8160	25200(*)	430		200kA @ 550V						

(1) at 850 V

(2) does not exist with blades

## Protistor® Square-body Fuses PSC aR sizes 7x - 650 V to 1300 VAC American Terminals - 70 - 73 End contacts

Size	Designation	Reference Number	Weight (g)	Packaging	Catalog Number
70	A130URD 70 TTI 0063	Q301015	350	3	A130UD70TTI63
	A130URD 70 TTI 0080	R301016			A130UD70TTI80
	A130URD 70 TTI 0100	S301017			A130UD70TTI100
	A130URD 70 TTI 0125	T301018			A130UD70TTI125
	A130URD 70 TTI 0160	V301019			A130UD70TTI160
	A130URD 70 TTI 0200	W301020			A130UD70TTI200
	A130URD 70 TTI 0250	X301021			A130UD70TTI250
	A130URD 70 TTI 0280	Y301022			A130UD70TTI280
	A130URD 70 TTI 0315	Z301023			A130UD70TTI315
	A120URD 70 TTI 0350	A301024			A120UD70TTI350
71	A130URD 71 TTI 0160	B301025	500	3	A130UD71TTI160
	A130URD 71 TTI 0200	C301026			A130UD71TTI200
	A130URD 71 TTI 0250	D301027			A130UD71TTI250
	A130URD 71 TTI 0280	E301028			A130UD71TTI280
	A130URD 71 TTI 0315	F301029			A130UD71TTI315
	A130URD 71 TTI 0350	G301030			A130UD71TTI350
	A130URD 71 TTI 0400	H301031			A130UD71TTI400
	A130URD 71 TTI 0450	J301032			A130UD71TTI450
	A130URD 71 TTI 0500	K301033			A130UD71TTI500
	A120URD 71 TTI 0550	L301034			A120UD71TTI550
72	A120URD 71 TTI 0630	M301035	850	3	A120UD71TTI630
	A130URD 72 TTI 0280	N301036			A130UD72TTI280
	A130URD 72 TTI 0315	P301037			A130UD72TTI315
	A130URD 72 TTI 0350	Q301038			A130UD72TTI350
	A130URD 72 TTI 0400	R301039			A130UD72TTI400
	A130URD 72 TTI 0450	S301040			A130UD72TTI450
	A130URD 72 TTI 0500	T301041			A130UD72TTI500
	A130URD 72 TTI 0550	V301042			A130UD72TTI550
	A130URD 72 TTI 0630	W301043			A130UD72TTI630
	A120URD 72 TTI 0700	X301044			A120UD72TTI700
73	A120URD 72 TTI 0800	Y301045	1250	3	A120UD72TTI800
	A130URD 73 TTI 0315	Z301046			A130UD73TTI315
	A130URD 73 TTI 0350	A301047			A130UD73TTI350
	A130URD 73 TTI 0400	B301048			A130UD73TTI400
	A130URD 73 TTI 0450	C301049			A130UD73TTI450
	A130URD 73 TTI 0500	D301050			A130UD73TTI500
	A130URD 73 TTI 0550	E301051			A130UD73TTI550
	A130URD 73 TTI 0630	F301052			A130UD73TTI630
	A130URD 73 TTI 0700	G301053			A130UD73TTI700
	A130URD 73 TTI 0800	H301054			A130UD73TTI800
	A130URD 73 TTI 0900 **	J301055			A130UD73TTI900
	A110URD 73 TTI 1000 **	K301056			A110UD73TTI1000
	A100URD 73 TTI 1100 **	L301057			A100UD73TTI1100
	A100URD 73 TTI 1250 **	M301058			A100UD73TTI1250
	A090URD 73 TTI 1400 **	N301059			A090UD73TTI1400
	A070URD 73 TTI 1600 **	O300877			A070UD73TTI1600
A065URD 73 TTI 1800 **	R300878	A065UD73TTI1800			

Size	A	B	C	D	E±1	d	G±0.1	P±0.1
70	40 1-9/16"	46,5 1-27/32"	82 3-7/32"	26 1-1/64"	74 2-29/32"	5/16"-18	9 23/64"	6 15/64"
71	51 2"	56,5 2-7/32"	91 3-37/64"	30 1-3/16"	74 2-29/32"	5/16"-18	9 23/64"	9 23/64"
72	60 2-3/8"	65,5 2-37/64"	100 3-15/16"	38 ; (42mm **) 1-1/2" ; (1-21/32" **)	74 2-29/32"	3/8"-16	15 19/32"	9 23/64"
73	74,5 2-15/16"	79,5 3-1/8"	114 4-1/2"	46 ; (52mm **) 1-13/16" ; (2-1/16" **)	74 2-29/32"	1/2"-13	15 19/32"	9 23/64"

**Note:**

Dimensions in mm

Dimensions in inches

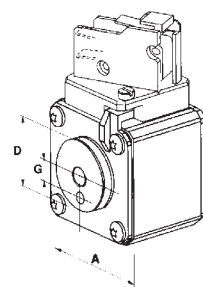
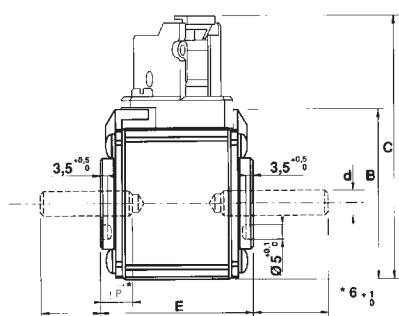

Microswitches and threaded studs supplied separately

## Protistor® Square-body Fuses PSC aR sizes 7x - 650 V to 1300 VAC Curves set

### Multiplier coefficient

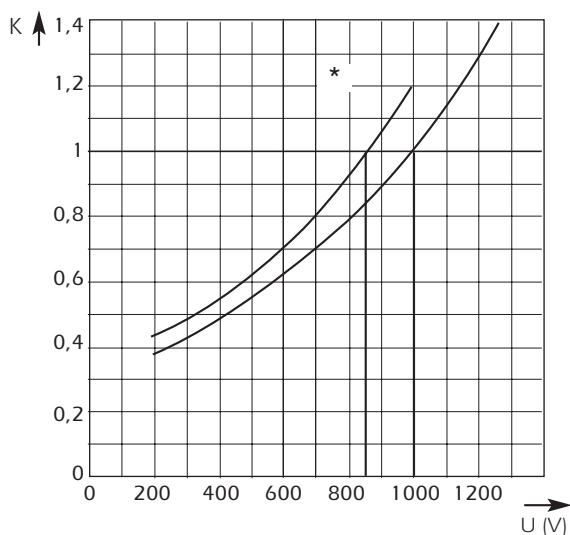

Left: Mean curve indicating variation of total  $I^2t$  ( $I^2t_t$ ) and total operating time  $T_t$  in accordance with working voltage  $U$ .

Example:  
Fuse 350 A in size 70.  
 $I_p = 10\,000$  A  $U = 1100$  V

At 1000 V  
 $I^2t_t = 115\,000$  A<sup>2</sup>s  $T_t = 7$  ms

At 1100 V  
 $I^2t_t = 115\,000 \times 1.13 = 130\,000$  A<sup>2</sup>s  
 $T_t = 7 \times 1.13 = 7.9$  ms

\* curve for fuses with  $I^2t$  published at 850VAC

### Dissipated power

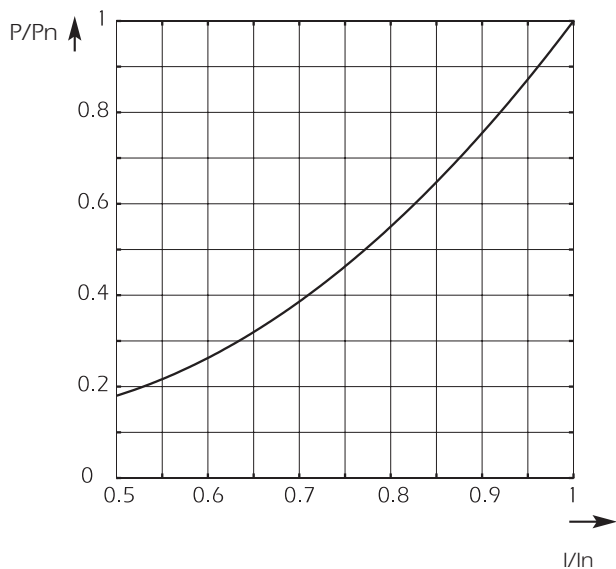

Above left: Curve enabling calculation of dissipated power  $P$  by a fuse rated  $I_n$ , as a function of the RMS current  $I$ , in multiples of  $I_n$ , in steady state.

### Arc voltage

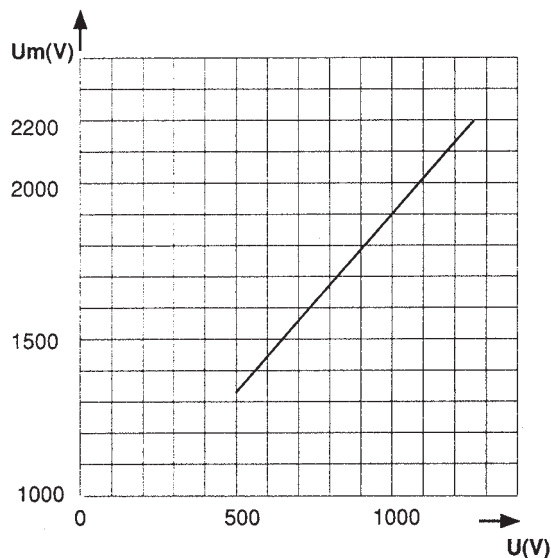

Above right: Curve indicating peak arc voltage  $U_m$  which may appear across fuse terminals as a function of working voltage  $U$  at  $\cos \varphi = 0.15$



## Protistor® Square-body Fuses PSC aR sizes 7x - 650 V to 1300 VAC Curves set

### Size 70

#### Cut-off characteristics

Curves indicating for each rated current the peak value  $I_C$  that the current may reach as a function of the prospective fault current  $I_p$ .

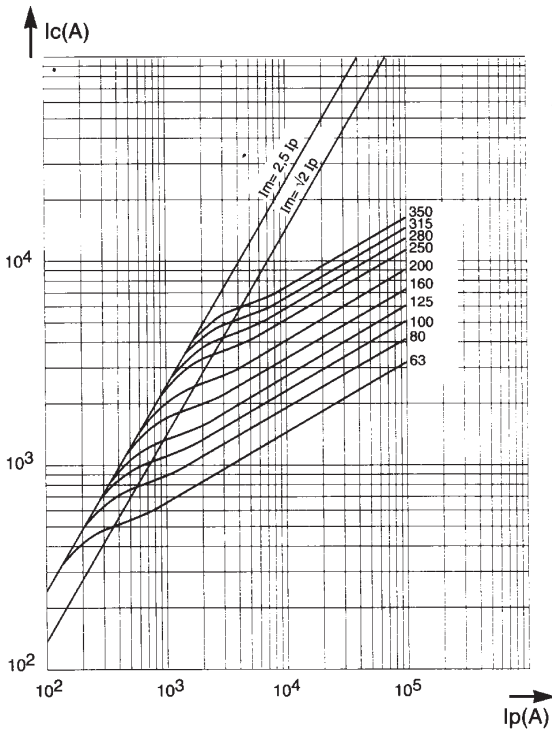

#### Time-current characteristics

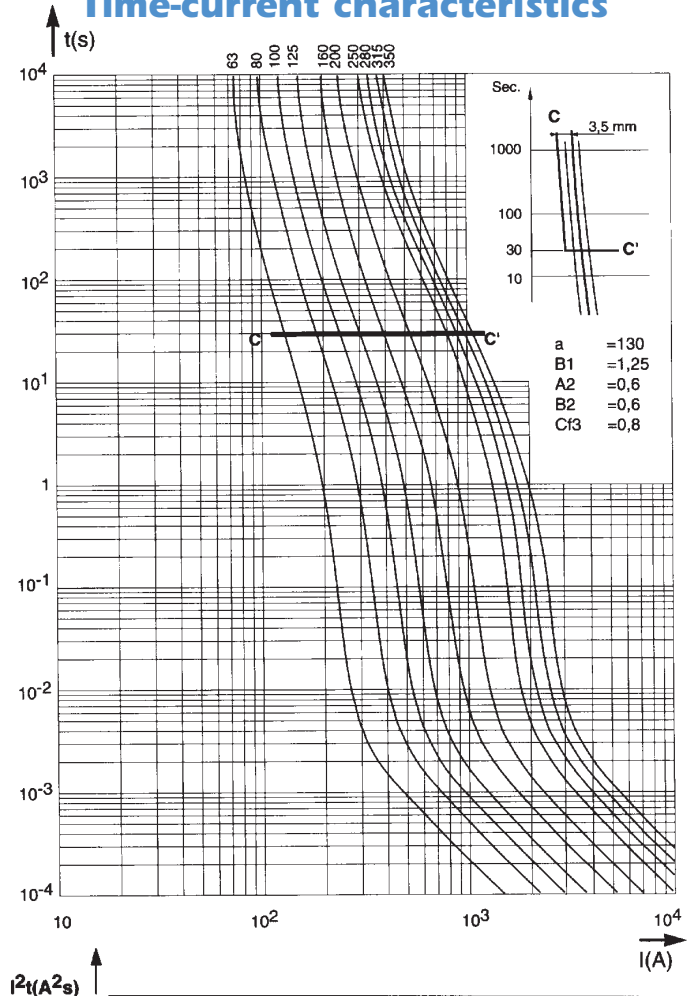

#### Time-current characteristics

- Curves indicating pre-arcing time for each rated current as a function of RMS value of pre-arcing current  $I$ .
- Tolerances on this current  $\pm 8\%$ .
- Beyond 30 sec, small overloads must be eliminated by another device.
- Curve CC' represents the maximum times taken by the associated device to clear small overloads; only its horizontal line is represented. Its oblique line must be plotted according to sketch, top right corner.
- The intersection of the fuse and CC' curves indicates the minimum breaking current  $I_{pm}$  of the fuse.

#### Maximum values of total operating $I^2t$ and total operating times

Horizontal curves indicating the maximum values of total operating  $I^2t$  ( $I^2t_t$ ) as function of the prospective current  $I_p$  at 1000V or 850 V(\*),  $\cos \varphi = 0.15$ .  
The oblique lines indicate the corresponding total operating time  $T_t$ , with pre-arcing time in brackets.

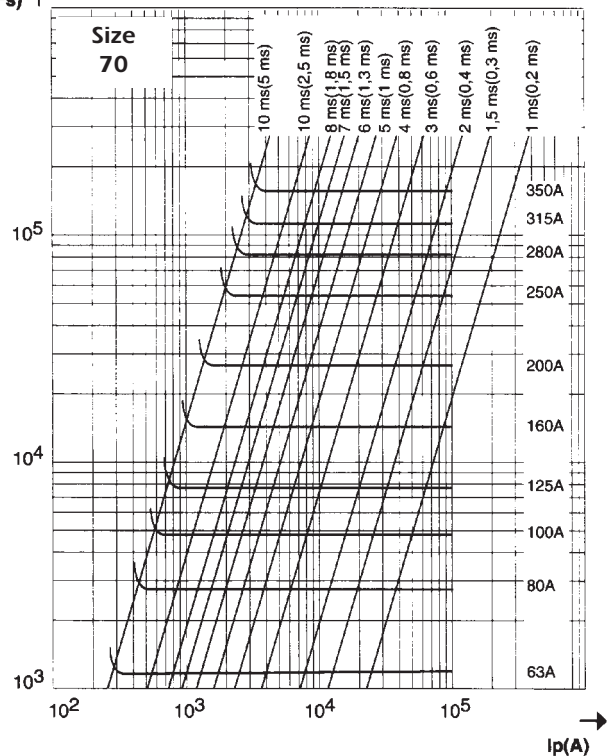

## Protistor® Square-body Fuses PSC aR sizes 7x - 650 V to 1300 VAC Curves set

### Cut-off characteristics

Curves indicating for each rated current the peak value  $I_C$  that the current may reach as a function of the prospective fault current  $I_p$ .

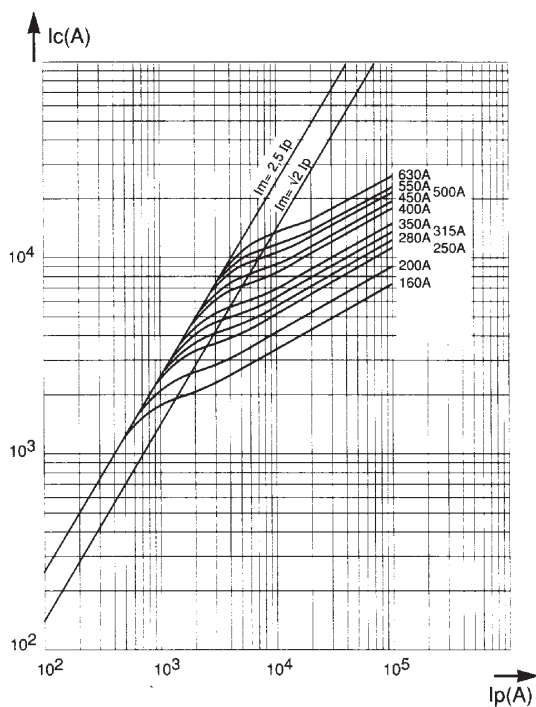

### Time-current characteristics

Curves indicating pre-arcing time for each rated current as a function of RMS value of pre-arcing current  $I$ .

- Tolerances on this current  $\pm 8\%$ .
- Beyond 30 sec, small overloads must be eliminated by another device.
- Curve CC' represents the maximum times taken by the associated device to clear small overloads; only its horizontal line is represented. Its oblique line must be plotted according to sketch, top right corner.
- The intersection of the fuse and CC' curves indicates the minimum breaking current  $I_{pm}$  of the fuse.

### Maximum values of total operating $I^2t$ and total operating times

Horizontal curves indicating the maximum values of total operating  $I^2t$  ( $I^2t_t$ ) as function of the prospective current  $I_p$  at 1000V or 850 V(\*),  $\cos \varphi = 0.15$ .

The oblique lines indicate the corresponding total operating time  $T_t$  with pre-arcing time in brackets.

### Size 71

### Time-current characteristics

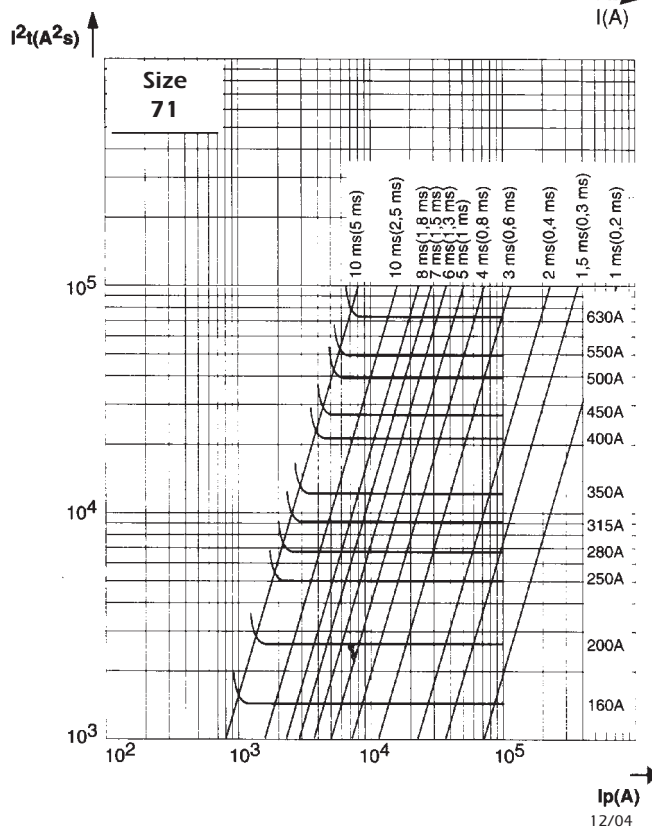
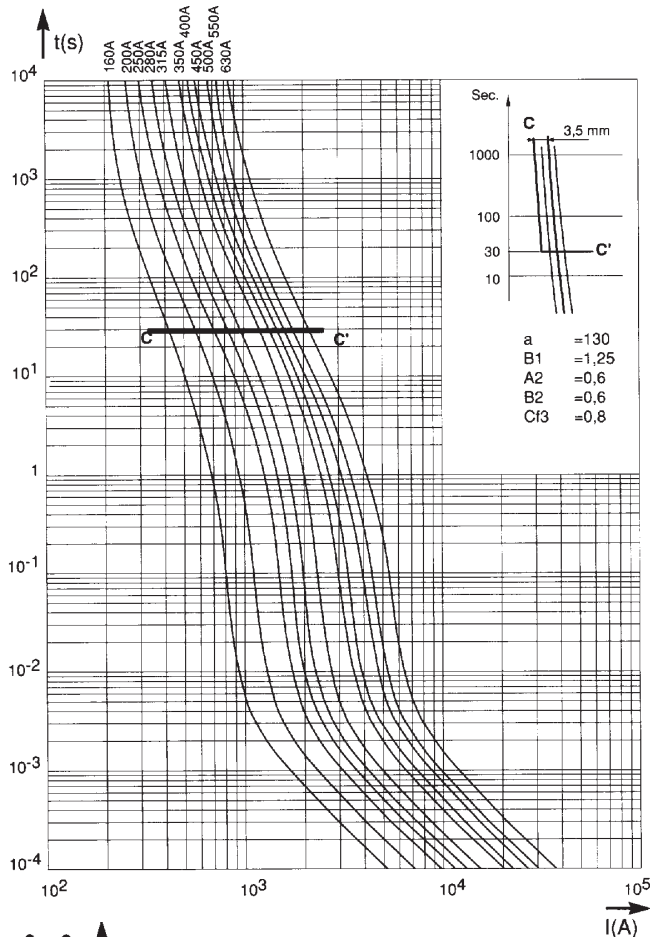



## Protistor® Square-body Fuses PSC aR sizes 7x - 650 V to 1300 VAC Curves set

### Size 72

#### Cut-off characteristics

Below, right: Curves indicating for each rated current the peak value  $I_C$  that the current may reach as a function of the prospective fault current  $I_p$ .

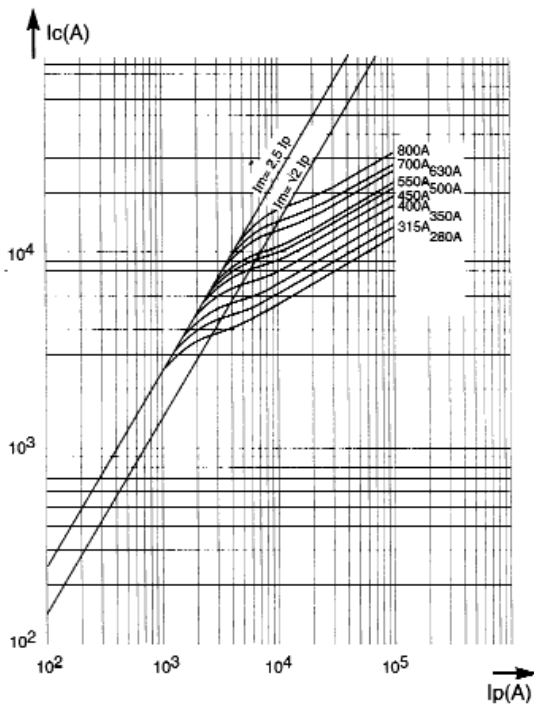

#### Time-current characteristics

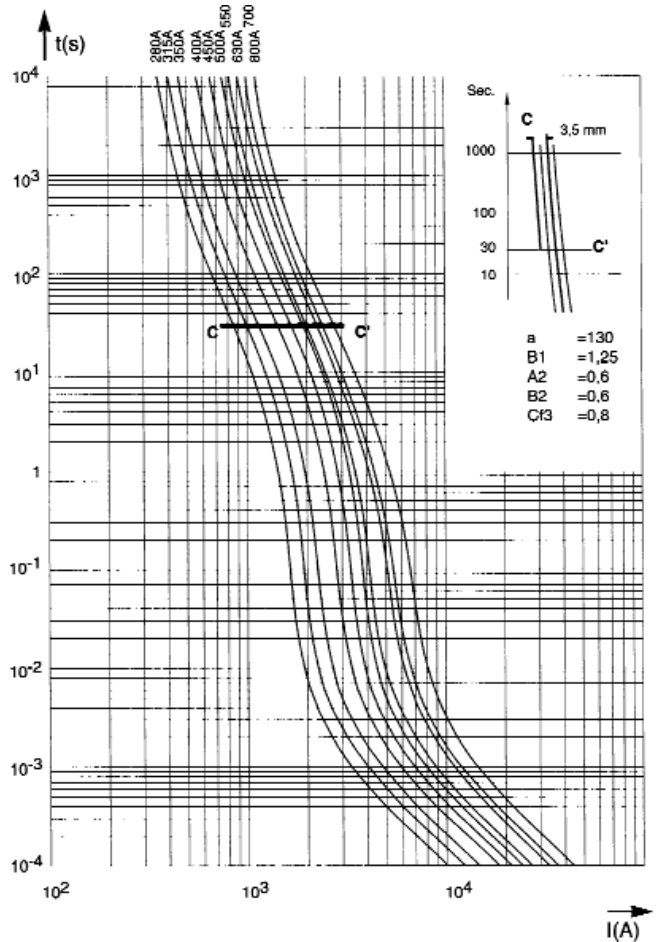

#### Time-current characteristics

Above, left: Curves indicating pre-arcing time for each rated current as a function of RMS value of pre-arcing current  $I$ .

- Tolerances on this current  $\pm 8\%$ .
- Beyond 30 sec, small overloads must be eliminated by another device.
- Curve CC' represents the maximum times taken by the associated device to clear small overloads; only its horizontal line is represented. Its oblique line must be plotted according to sketch, top right corner.
- The intersection of the fuse and CC' curves indicates the minimum breaking current  $I_{pm}$  of the fuse.

#### Maximum values of total operating $I^2t$ and total operating times

Left: Horizontal curves indicating the maximum values of total operating  $I^2t$  ( $I^2t_t$ ) as function of the prospective current  $I_p$  at 1000V or 850 V(\*),  $\cos \varphi = 0.15$ .

The oblique lines indicate the corresponding total operating time  $T_t$ , with pre-arcing time in brackets.

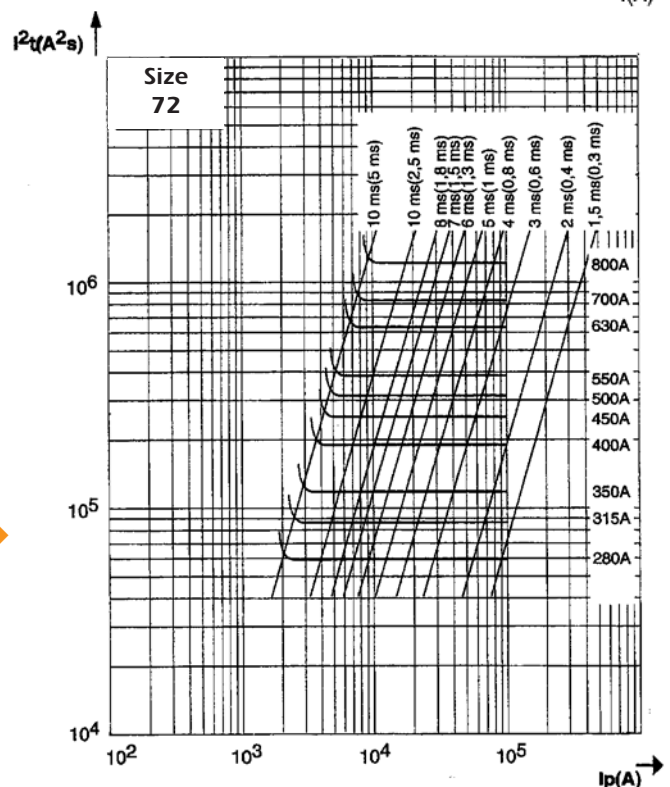

## Protistor® Square-body Fuses PSC aR sizes 7x - 650 V to 1300 VAC Curves set

Size 73

### Cut-off characteristics

Curves indicating for each rated current the peak value  $I_C$  that the current may reach as a function of the prospective fault current  $I_p$ .

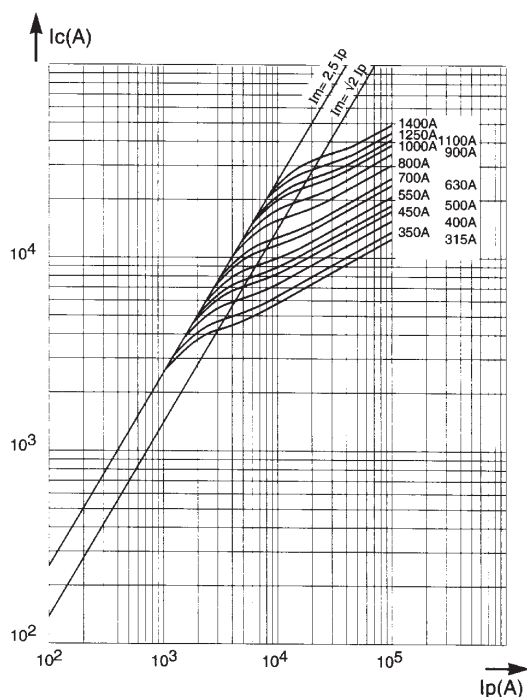

### Time-current characteristics

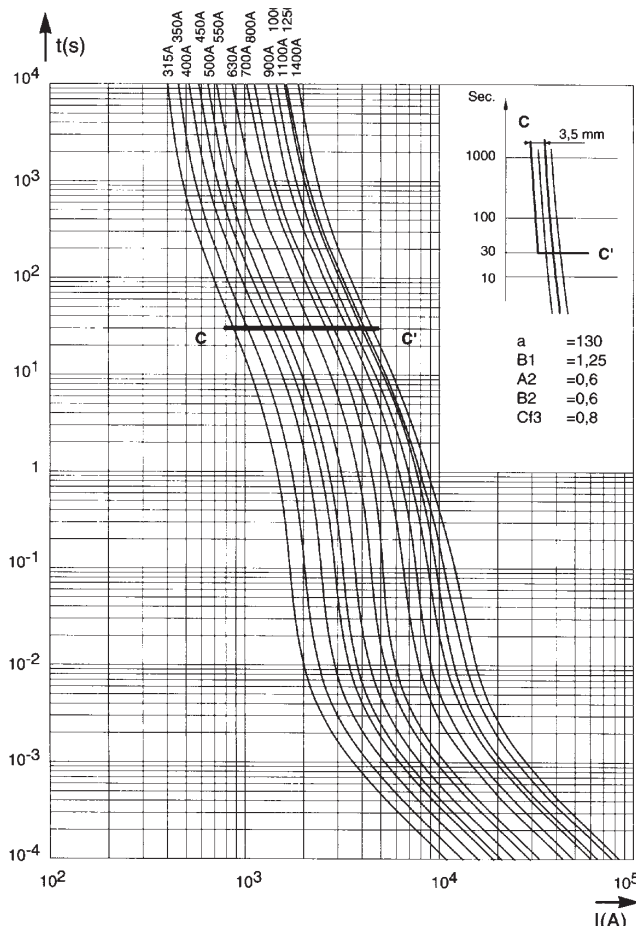

### Time-current characteristics

Curves indicating pre-arcing time for each rated current as a function of RMS value of pre-arcing current  $I$ .

- Tolerances on this current  $\pm 8\%$ .
- Beyond 30 sec, small overloads must be eliminated by another device.
- Curve CC' represents the maximum times taken by the associated device to clear small overloads; only its horizontal line is represented. Its oblique line must be plotted according to sketch, top right corner.
- The intersection of the fuse and CC' curves indicates the minimum breaking current  $I_{pm}$  of the fuse.

### Maximum values of total operating $I^2t$ and total operating times

Horizontal curves indicating the maximum values of total operating  $I^2t$  ( $I^2t_t$ ) as function of the prospective current  $I_p$  at 1000V or 850 V(\*),  $\cos \varphi = 0.15$ .

The oblique lines indicate the corresponding total operating time  $T_t$  with pre-arcing time in brackets.

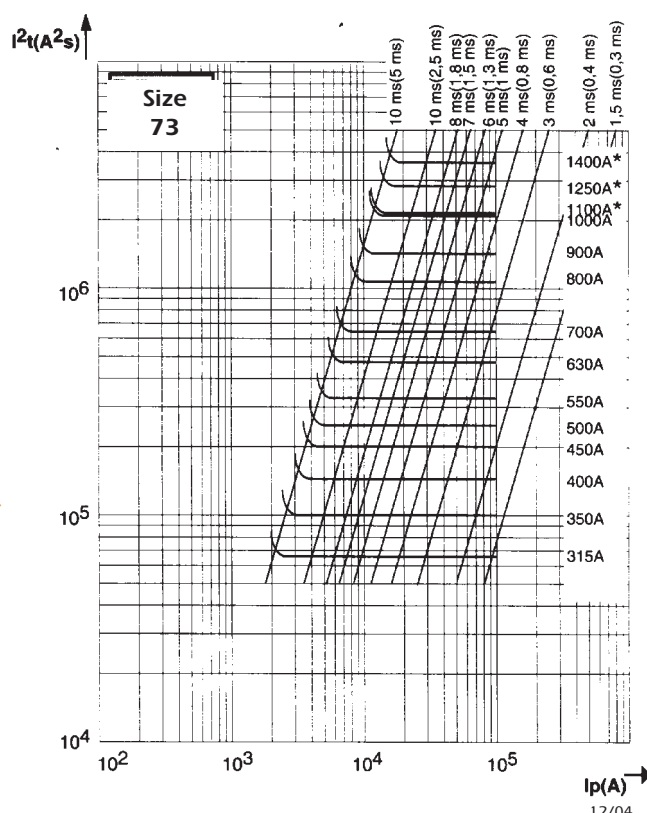

# Semiconductor (AC) fuses



## Protistor® Square-body Fuses PSC aR sizes 7x - 650 V to 1300 VAC Curves set

### Size 2x72

#### Cut-off characteristics

Curves indicating for each rated current the peak value  $I_C$  that the current may reach as a function of the prospective fault current  $I_p$ .

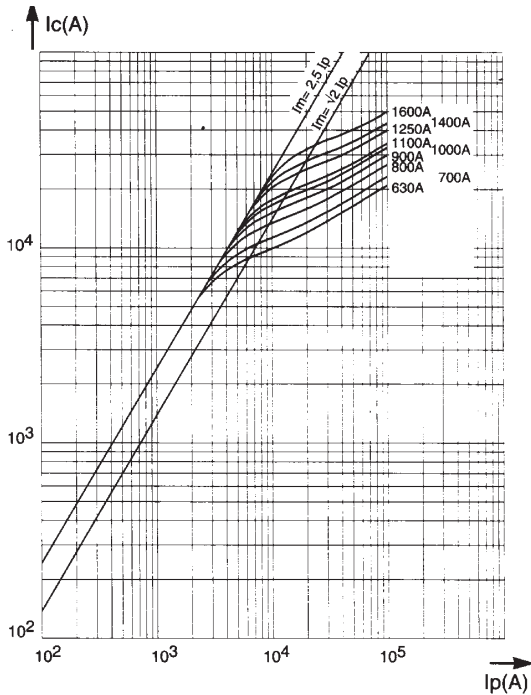

#### Time-current characteristics

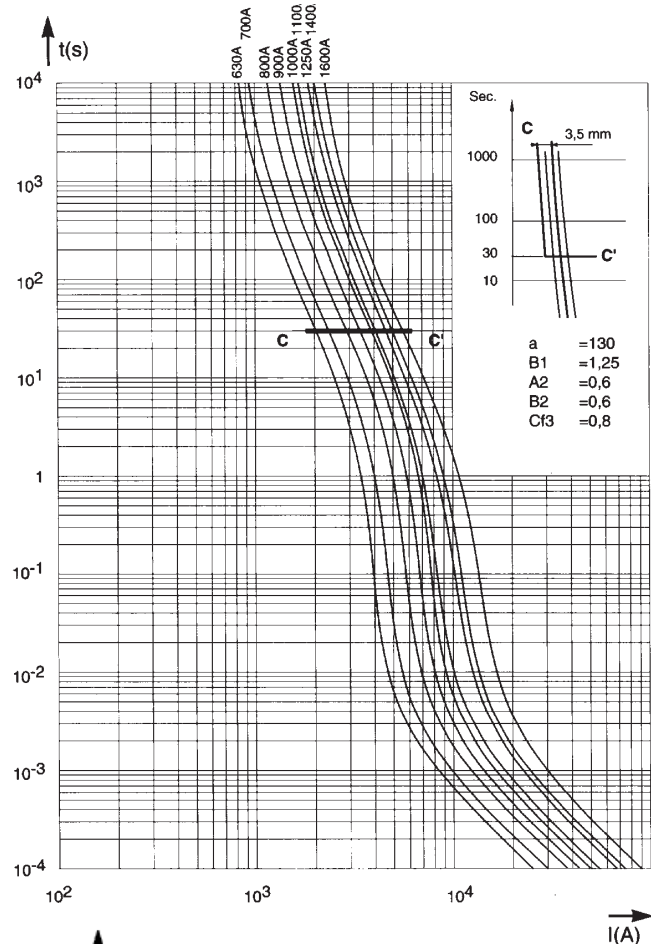

#### Time-current characteristics

Curves indicating pre-arcing time for each rated current as a function of RMS value of pre-arcing current  $I$ .

- Tolerances on this current  $\pm 8\%$ .
- Beyond 30 sec, small overloads must be eliminated by another device.
- Curve CC' represents the maximum times taken by the associated device to clear small overloads; only its horizontal line is represented. Its oblique line must be plotted according to sketch, top right corner.
- The intersection of the fuse and CC' curves indicates the minimum breaking current  $I_{pm}$  of the fuse.

#### Maximum values of total operating $I^2t$ and total operating times

Horizontal curves indicating the maximum values of total operating  $I^2t$  ( $I^2t_t$ ) as function of the prospective current  $I_p$  at 1000V or 850 V(\*),  $\cos \varphi = 0.15$ .

The oblique lines indicate the corresponding total operating time  $T_t$ , with pre-arcing time in brackets.

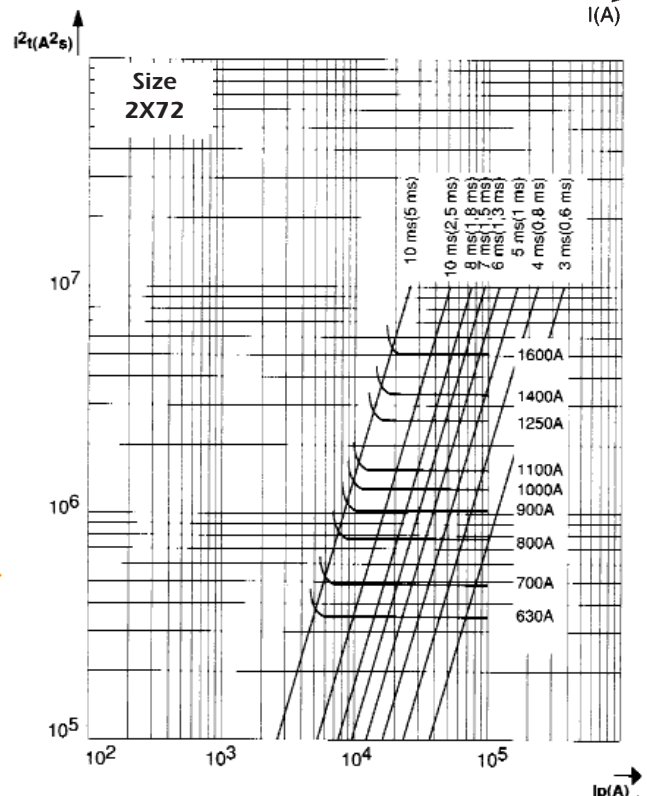

## Protistor® Square-body Fuses PSC aR sizes 7x - 650 V to 1300 VAC Curves set

### Cut-off characteristics

Curves indicating for each rated current the peak value  $I_C$  that the current may reach as a function of the prospective fault current  $I_p$ .

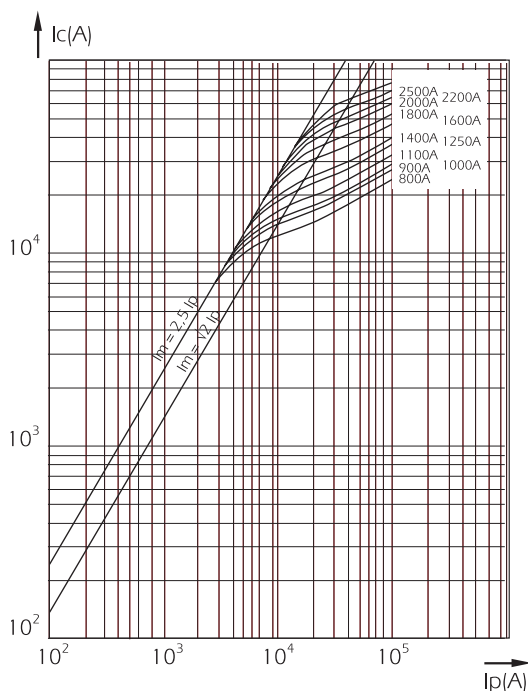

### Time-current characteristics

Curves indicating pre-arcing time for each rated current as a function of RMS value of pre-arcing current  $I$ .

- Tolerances on this current  $\pm 8\%$ .
- Beyond 30 sec, small overloads must be eliminated by another device.
- Curve CC' represents the maximum times taken by the associated device to clear small overloads; only its horizontal line is represented. Its oblique line must be plotted according to sketch, top right corner.
- The intersection of the fuse and CC' curves indicates the minimum breaking current  $I_{pm}$  of the fuse.

### Maximum values of total operating $I^2t$ and total operating times

Horizontal curves indicating the maximum values of total operating  $I^2t$  ( $I^2t_t$ ) as function of the prospective current  $I_p$  at 1000V or 850 V(\*),  $\cos \varphi = 0.15$ .

The oblique lines indicate the corresponding total operating time  $T_t$ , with pre-arcing time in brackets.

Size 2x72

### Time-current characteristics

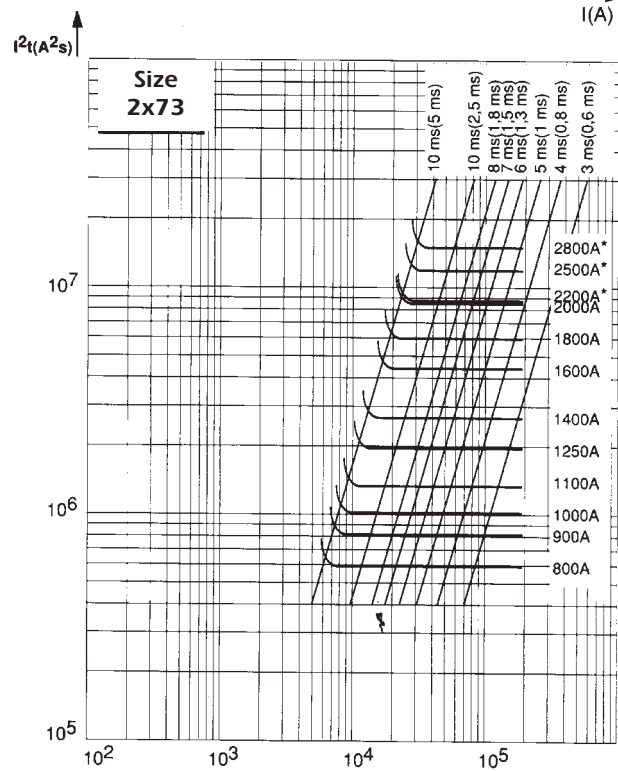
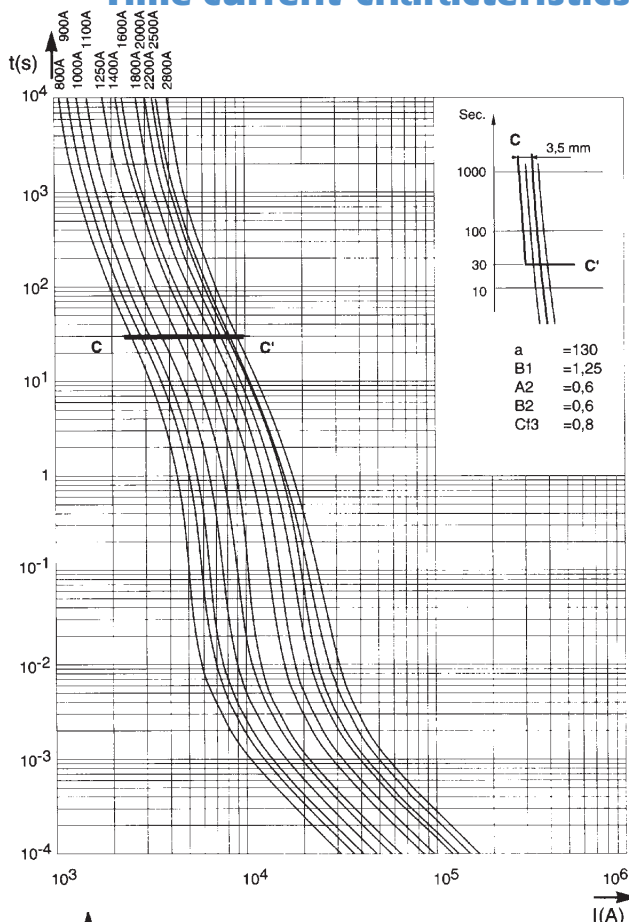



## Protistor® Square-body Fuses PSC aR sizes 7x - 650 V to 1300 VAC Curves set

### DC working voltage possibilities

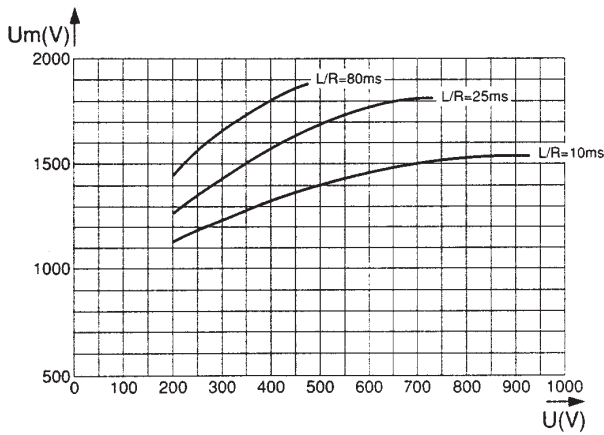
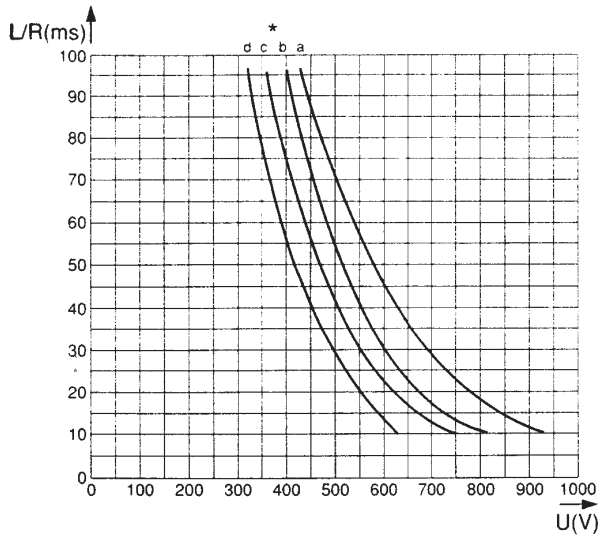

Top: Curves indicating the maximum time constant  $L/R$  of the fault path as a function of the DC voltage  $U$ , for the rated currents in the sizes indicated in the table.

$I_{pm}$  (1) values indicate the minimum breaking current in Amperes (A).

Remark: When the fault current  $di/dt$  is very large, this condition can be exceeded. It is the case for faults occurring in voltage commutated inverters.

Below: Curves indicating peak arc voltage  $U_m$  which may appear across fuse terminals as a function of the DC working voltage  $U$ , for various time constant  $L/R$  of fault path.

Rated current $I_N$ (A)	Curves (*) and $I_{pm}$ (1) corresponding to the rating											
		70 * $I_{pm}$ (A)	71 * $I_{pm}$ (A)	72 * $I_{pm}$ (A)	73 * $I_{pm}$ (A)	2x72 * $I_{pm}$ (A)	2x73 * $I_{pm}$ (A)					
63	a	270										
80	a	400										
100	a	520										
125	a	700										
160	a	950	a	950								
200	a	1300	a	1300								
250	a	1800	a	1800								
280	b	2200	a	2000	a	1800						
315	b	2600	a	2300	a	2200	a	2000				
350	c	3000	a	2700	a	2600	a	2400				
400			b	3500	a	3200	a	3000				
450			b	4000	a	3800	a	3500				
500			c	4800	a	4600	a	3900				
550			c	5200	b	5000	a	4400				
630			c	6400	b	6200	a	5300	a	4400		
700				c	6800	a	6000	a	5200			
800					c	8000	b	8000	a	6400	a	6000
900							b	9000	a	7600	a	7000
1000							c	11000	a	9200	a	7800
1100							c	12000	b	10000	a	8800
1250							c	13500	b	12400	a	10600
1400							c	15000	c	13600	a	12000
1600								c	16000	b	16000	
1800											b	18000
2000											c	22000
2200											c	24000
2500											d	27000
2800											d	30000

## Protistor® Square-body Fuses PSC aR sizes 3x - 450V to 700 VAC Microswitches PSC 3x & 7x

- MICROSWITCH SYSTEMS ADAPTED

TO THE FOLLOWING FERRAZ SHAWMUT FUSES ONLY:

- PSC sizes 30, 31, 32, 33, 2x32, 2x33 / 70, 71, 72, 73, 272, 273  
except plain blades

- PSC LR sizes 33, 233, 73, 273

- PERMANENT INDICATION OF FUSE STATE: CONDUCTIVE  
BLOWN

- MANUAL RESETTING

- STANDARD AND LOW ELECTRICAL LEVEL WITH DIFFERENT INSULATION LEVELS

- BS TYPE FOR USE IN CORROSIVE ATMOSPHERE

- MS 3V 1-5 UR AND MS 7V 1-5 UR TYPE UL ARE RECOGNIZED



MS 7V 1-5

### Main Characteristics

Code	AC Insulation voltage rating (***)	Positive operating voltage/current	Current rating	Current	Breaking Capacity						AC voltage withstand test (*)	Impulse voltage test Uimp1.2/50 µs (**)	Fire class according to UL 94
					Non inductive circuit			Inductive circuit : L/R = 25ms					
					30V	110V	250V	30V	110V	250V			
MS 3V 1-5	1000 V	20 V 50 mA	10 A	50/60 Hz	10 A	10 A	10 A	10 A	10 A	10 A	8,5 kV	14 kV	H.B
MS 3V 1-5 UR				DC	8 A	0,4 A	0,2 A	4 A	0,2 A	0,1 A			
MS 7V 1-5	1500V	10 V 10 mA	3 A	50/60 Hz	3 A	3 A	3 A	2 A	1 A	1 A	8,5 kV	14 kV	
MS 7V 1-5 UR				DC	3 A	0,5 A	0,25 A	3 A	0,2 A	0,1 A			
MS 3V 1-5 BS	1000 V	10 V 10 mA	3 A	50/60 Hz	3 A	3 A	3 A	2 A	1 A	1 A	8,5 kV	14 kV	
MS 3V 1-9 BS				DC	3 A	0,5 A	0,25 A	3 A	0,2 A	0,1 A			
MS 7V 1-5 BS	1500V	10 V 10 mA	3 A	50/60 Hz	3 A	3 A	3 A	2 A	1 A	1 A	8,5 kV	14 kV	
MS 7V 1-9 BS				DC	3 A	0,5 A	-	2 A	0,2 A	-			
MS 3V 1-5 ET	1000V	10 V	3 A	50/60 Hz	3 A	3 A	3 A	2 A	1 A	1 A	8,5 kV	14 kV	
MS 7V 1-5 ET	1500V	10 mA	3 A	DC	3 A	0,5 A	-	2 A	0,2 A	-	12 kV	20 kV	

\* Between power circuit and microswitch terminals as per IEC 60 and 694 and NFC 64010 (50/60 Hz 1 min duration in dry air)

\*\* Between power circuit and microswitch terminals Uimp: impulse voltage as per IEC 60947-1

\*\*\* Between power circuit and microswitch terminals

**Warning:** microswitch systems exclusively designed for FERRAZ SHAWMUT.  
PSC Fuses fitted a patented trip-indicator, saving use of EDV



## Protistor® Square-body Fuses PSC aR sizes 3x - 450V to 700 VAC Microswitches for PSC 3x &7x

### Indication systems for PSC Fuse sizes 30 to 73 MS 3V...

These patented indication systems are exclusively hand resettable.

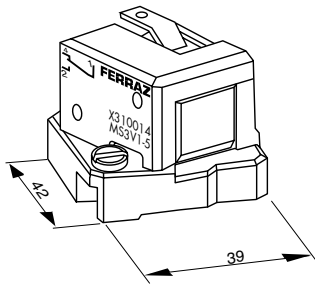

(fig. 1)

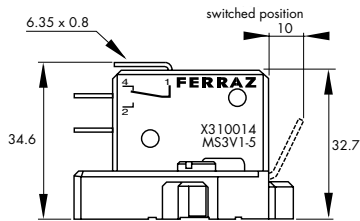

Fuse size	Designation	Ref. Number	Indication style	Weight (g)	Pack.	Catalog Number
30, 31 32, 33	MS 3V 1-5 (fig.1)	X310014	Standard NO-NC	34	3 pieces	MS3 V1-5
	MS 3V 1-5 UR	Y310038				MS3 V1-5UR
	MS 3V 1-5 BS (3)	K310013	Low level NO-NC	34	3 pieces	MS3-V1-5BS
	MS 3V 1-9 BS (4)	P310011	Double pole Low level	44	3 pieces	MS3V1-9BS
	MS 3V 1-5 ET (fig.2)	S310009	Low level NO-NC IP 50 (9)	34	3 pieces	MS3V1-5 ETANCHE

(3) Same as fig.1

(4) Same dimensions as figure 1 but with 2 microswitches side by side

(9) Watertightness class

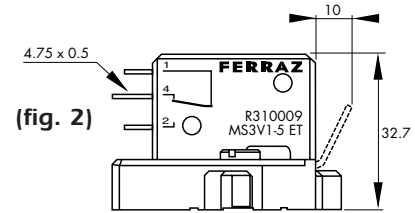

(fig. 2)

### MS 7V...

Fuse size	Designation	Ref. Number	Indication style	Weight (g)	Pack.	Catalog Number
70, 71 72, 73	MS 7V 1-5 (fig.5)	J310002	Standard NO-NC	45	3 pieces	MS7 V1-5
	MS 7V 1-5 UR	Z310039				MS7 V1-5UR
	MS 7V 1-5 BS (3)	K310003	Low level NO-NC	45	3 pieces	MS7-V1-5BS
	MS 7V 1-9 BS (4)	P310007	Double pole Low level	55	3 pieces	MS7V1-9BS
	MS 7V 1-5 ET (fig.6)	S310010	Low level NO-NC IP 50 (9)	55	3 pieces	MS7V1-5 ETANCHE

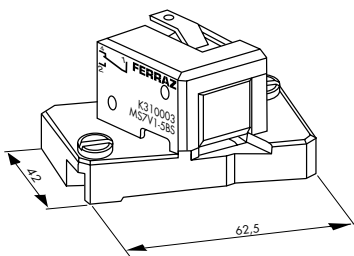

(fig. 5)

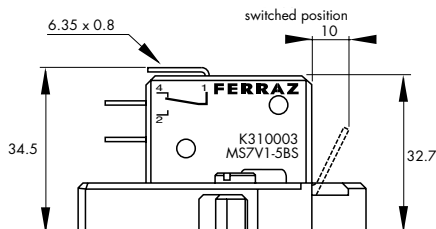

(7) Same as fig. 5

(8) Same dimensions as figure 5 but with 2 microswitches side by side

(9) Watertightness class

**Warning:** Microswitch systems exclusively designed for FERRAZ SHAWMUT PSC fuses fitted with a patented trip-indicator, saving use of EDV.

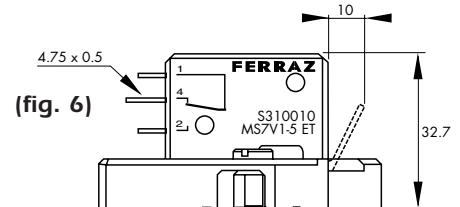

(fig. 6)

# Semiconductor (AC) fuses

## Protistor® Square-body Fuses PSC gR sizes 7x - 690 VAC Metric-studs

### Metric studs for threaded terminal fuses



Type and fuse size	Designation	Ref. Number	Unit weight (g)	Pack.	Catalog Number
 Sizes 0 and 1	HC stud pair M8x30 & M8x35	S098801	23	6 pairs	STU M8x30 M8x35
	Size 2 HC stud pair M10x30 & M10x50	T098802	40	6 pairs	STU M10x30 M10x50
	Size 3 HC stud pair M12x35 & M12x50	V098803	60	6 pairs	STU M12x35 M12x50
 Size 2	HC stud pair M10x50	W098804	45	6 pairs	STU M10x50
	Size 3 HC stud pair M12x50	X098805	45	6 pairs	STU M12x50

We recommend the use of studs, whose quality is suited to all FERRAZ SHAWMUT square-body fuses with terminals

### Stud mounting

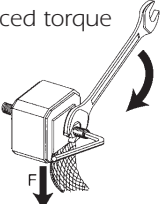
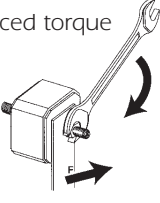
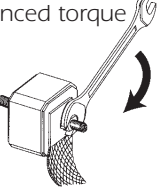
Torque type	Stud type	Maximum stud tightning torque (Nm) (1)	Maximum nut tightning torque (Nm) (1)
Balanced torque 	M8x30 & M8x35	10	13.5
	M10x30 & M10x50	15	26
	M12x35 & M12x50	15	46
Balanced torque 	M8x30 & M8x35	10	13.5
	M10x30 & M10x50	15	26
	M12x35 & M12x50	15	46
Unbalanced torque 	M8x30 & M8x35	10	13.5
	M10x30 & M10x50	15	26
	M12x35 & M12x50	15	46

(1) Factory limit on torque at 20°C ambient: +0, -2Nm; except on 46Nm value (+0, -4Nm)