

## Protistor® Square-body Fuses PSC gR sizes 7x - 690 VAC Main characteristics



6,9 gRB 71 PA 200



6,9 gRB 73 TTF 1000  
+ MS7V1-5 UR



6,9 gRB 70 EF 400



6,9 gRB 73 DIIA 1000

Ferraz Shawmut PSC-gRB 690 VAC fuse-links provide maximum flexibility in equipment design and ultimate protection for today's power conversion equipment.

This range is a fast acting, full range fuses engineered to provide state of the art protection for power semiconductors such as diodes, thyristors.

These square body fuse-links are available in various body sizes with a broad range of ampere ratings allowing the greatest flexibility in equipment design.

They have pure silver fuse elements embedded in solidified sand which provides optimized  $I^2t$  and high breaking capacity. All contact surfaces are plated and all hardware non-magnetic.

All fuses are standard with a low voltage blown fuse indicator. This indicator can operate a microswitch which is easily mounted directly on to the fuse in service.

### Feature

- Full range (gR curve), fast acting
- Highly current limiting.
- High breaking capacities
- Very low  $I^2t$
- Worldwide mounting acceptance.
- Superior cycling ability.
- High withstanding in rush current and overloads

### Ratings

**AC:** up to 1000 A 690 VAC  
150 kA IR

**DC:** Consult Factory

### Applications

Protection of rectifiers, inverters, static switch, AC & DC drives and UPS systems.

**AC:** Tested to IEC 60269.4

### approvals

### Features/Benefits

**Wide range of mounting styles**

**Broad range of ampere ratings** in each body size for design flexibility

**IEC 60269-4 compliance** for fuses for worldwide semiconductor applications



## Protistor® Square-body Fuses PSC gR sizes 7x - 690 VAC Main characteristics

Voltage	Size	Type	Rating In (A)	Pre-Arcing I <sup>2</sup> t @ 1ms kA <sup>2</sup> s	Total I <sup>2</sup> t @ 690V kA <sup>2</sup> s	PN: Power losses (W)				Breaking capacities (kA)
						End contacts		Blades		
						0,8 In	In	0,8In	In	
690V	70	gRB	50	0,12	0,7	9	17	9	17	150
		gRB	63	0,27	1,6	9	18	9	18	
		gRB	80	0,47	2,8	11	22	11	22	
		gRB	100	1,06	6,2	12	23	12	23	
		gRB	125	1,9	11,2	13	26	13	26	
		gRB	160	4,2	25	15	29	15	29	
		gRB	200	7,5	44	17	33	17	34	
		gRB	250	13,5	79	20	39	20	40	
		gRB	315	24	142	23	46	24	47	
	gRB	350	41	240	23	46	24	47		
	gRB	125	1,06	6,2	18	35	18	35		
	gRB	160	2,4	14	19	38	19	38		
	gRB	200	5	29,5	21	41	21	42		
	gRB	250	9,5	56	23	46	24	48		
	gRB	315	18,5	108	27	53	27	54		
	gRB	350	23	140	29	58	30	60		
	gRB	400	38	225	30	59	31	61		
	gRB	450	62	360	30	59	31	61		
	gRB	500	78	460	32	64	34	67		
	gRB	200	4,2	25	23	45	23	45		
	gRB	250	8,5	50	25	49	25	50		
	gRB	315	17	100	28	55	29	57		
	gRB	350	23	140	29	58	30	60		
	gRB	400	34	200	32	63	33	65		
	gRB	450	47	280	34	67	35	70		
	gRB	500	68	400	35	69	36	72		
	gRB	550	84	495	38	75	39	78		
	gRB	630	124	730	41	81	43	86		
	gRB	700	155	910	45	89	48	95		
	gRB	315	12	69	33	66	34	67		
	gRB	350	17	100	34	68	35	69		
	gRB	400	27	160	36	71	37	73		
	gRB	450	34	200	40	79	41	82		
	gRB	500	47	280	42	84	43	86		
	gRB	550	68	400	42	84	44	87		
	gRB	630	102	600	45	89	47	94		
	gRB	700	139	820	47	94	50	100		
	gRB	800	227	1330	48	96	52	104		
	gRB	900	280	1640	55	109	60	119		
	gRB	1000	385	2270	58	115	64	127		

Time/current characteristics  
Cut off characteristics  
Total I<sup>2</sup>t and total operating time  
Other curves

} see following pages



## Protistor® Square-body Fuses PSC gR sizes 7x - 690 VAC French 70-73 Blades

Size	Designation	Reference Number	Weight (g)	Catalog Number
70	6,9 gRB 70 EF 050	P301405	370	PC70GB69V50EF
	6,9 gRB 70 EF 063	Q301406		PC70GB69V63EF
	6,9 gRB 70 EF 080	R301407		PC70GB69V80EF
	6,9 gRB 70 EF 100	S301408		PC70GB69V100EF
	6,9 gRB 70 EF 125	T301409		PC70GB69V125EF
	6,9 gRB 70 EF 160	V301410		PC70GB69V160EF
	6,9 gRB 70 EF 200			
	6,9 gRB 70 EF 250			
	6,9 gRB 70 EF 315			
71	6,9 gRB 71 EF 125	Y301321	540	PC71GB69V125EF
	6,9 gRB 71 EF 160	Z301322		PC71GB69V160EF
	6,9 gRB 71 EF 200	A301323		PC71GB69V200EF
	6,9 gRB 71 EF 250	B301324		PC71GB69V250EF
	6,9 gRB 71 EF 315			
	6,9 gRB 71 EF 350	C301325		PC71GB69V350EF
	6,9 gRB 71 EF 400	D301326		PC71GB69V400EF
	6,9 gRB 71 EF 450	E301327		PC71GB69V450EF
	6,9 gRB 71 EF 500	G301858		PC71GB69V500EF
72	6,9 gRB 72 EF 200	N301335	810	PC72GB69V200EF
	6,9 gRB 72 EF 250	P301336		PC72GB69V250EF
	6,9 gRB 72 EF 315	Q301337		PC72GB69V315EF
	6,9 gRB 72 EF 350			
	6,9 gRB 72 EF 400	R301338		PC72GB69V400EF
	6,9 gRB 72 EF 450			
	6,9 gRB 72 EF 500	S301339		PC72GB69V500EF
	6,9 gRB 72 EF 550	T301340		PC72GB69V550EF
	6,9 gRB 72 EF 630	V301341		PC72GB69V630EF
73	6,9 gRB 73 EF 315	C301348	1150	PC73GB69V315EF
	6,9 gRB 73 EF 350			
	6,9 gRB 73 EF 400	D301349		PC73GB69V400EF
	6,9 gRB 73 EF 450	E301350		PC73GB69V450EF
	6,9 gRB 73 EF 500			
	6,9 gRB 73 EF 550	F301351		PC73GB69V550EF
	6,9 gRB 73 EF 630	G301352		PC73GB69V630EF
	6,9 gRB 73 EF 700	H301353		PC73GB69V700EF
	6,9 gRB 73 EF 800			
6,9 gRB 73 EF 900				
6,9 gRB 73 EF 1000				

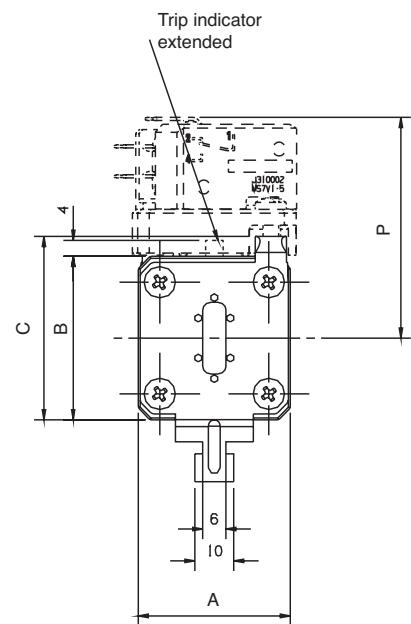
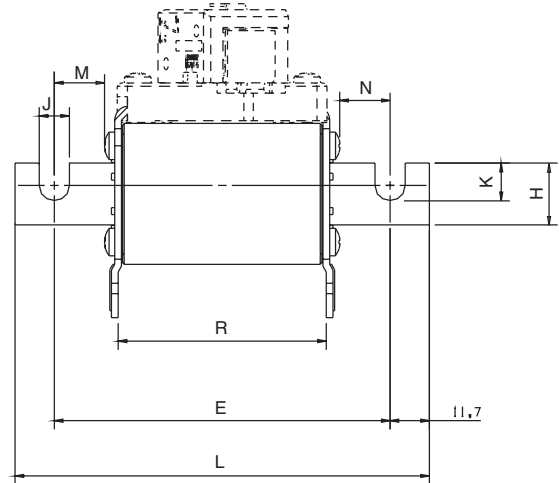

**Packaging:** 3 pieces sizes 70 and 71 / 1 piece size 72 and 73

Microswitches: MS 7V 1-5		Réf.J310002	Standard NO-NC
MS 7V 1-5 UR		Réf.Z310039	Standard NO-NC
MS 7V 1-5 BS		Réf.K310003	Low level NO-NC
MS 7V 1-9 BS		Réf.P310007	Double pole NO-NC-low level
MS 7V 1-5 ET		Réf.S310010	Low level NO-NC-IP 50

Microswitches supplied separately

Size	A	B	C	E <sup>+1,3</sup>	H	J	K	L <sup>+1,5</sup>	M	N	P	R
70	39,8	41,8	46,5	100	18	9	11	123,4	28,2	28,2	77	68
	1.57"	1.65"	1.83"	3.94"	0.71"	0.35"	0.43"	4.86"	1.11"	1.11"	3.03"	2.68"
71	51	51	56,5	110	25	10,5	16	133,4	32,7	32,7	91	68
	2.00"	2.00"	2.22"	4.33"	0.98"	0.41"	0.63"	5.25"	1.29"	1.29"	3.58"	2.68"
72	60	60	65,5	114,4	32	13	21,2	149,4	40,7	40,7	100	68
	2.36"	2.36"	2.58"	4.50"	1.26"	0.51"	0.83"	5.88"	1.60"	1.60"	3.93"	2.68"
73	74,4	74,4	78,5	114,4	40	13	19,5	149,4	40,7	40,7	114,4	68
	2.93"	2.93"	3.09"	4.50"	1.58"	0.51"	0.77"	5.88"	1.60"	1.60"	4.50"	2.68"

Reinforced and longer knives available under designation ESF  
Fuse holder solution, see Fuse gear section.

## Protistor® Square-body Fuses PSC aR sizes 3x - 450V to 700 VAC Curves set

Sizes 30 - 31 - 32 - 33

### I<sup>2</sup>t Multiplier coefficient

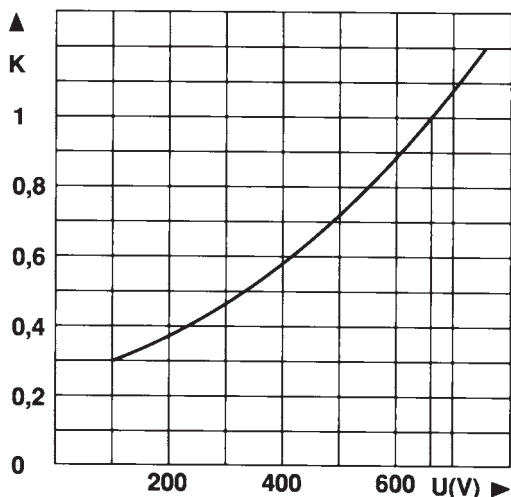

Mean curve indicating variation of total I<sup>2</sup>t (I<sup>2</sup>t<sub>t</sub>) and total operating time T<sub>t</sub> in accordance with working voltage U.

#### Example:

Fuse 350 A in size 30.  
I<sub>p</sub> = 10 000 A U = 500 V

At 660 V  
I<sup>2</sup>t<sub>t</sub> = 80 000 A<sup>2</sup>s T<sub>t</sub> = 6 ms

At 500 V  
I<sup>2</sup>t<sub>t</sub> = 80 000 × 0.72 = 57 600 A<sup>2</sup>s  
T<sub>t</sub> = 6 × 0.72 = 4.3 ms

### Dissipated power

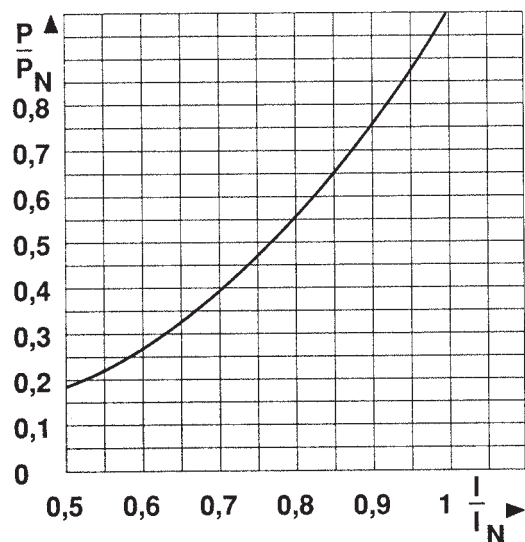

Curve enabling calculation of dissipated power P by a fuse rated I<sub>N</sub>, as a function of the RMS current I, in multiples of I<sub>N</sub>, in a steady state.

### Arc voltage

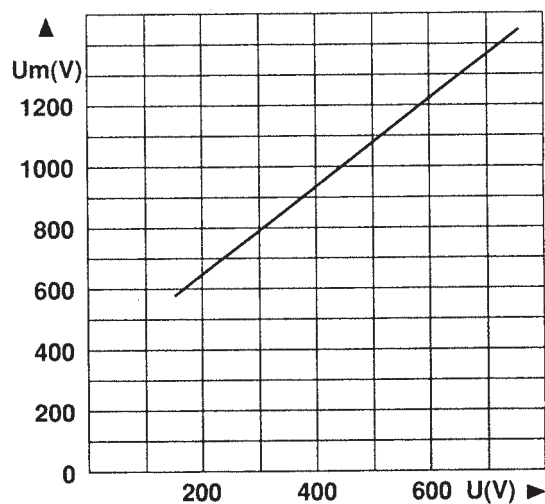

Curve indicating peak arc voltage U<sub>m</sub> which may appear across fuse terminals as function of working voltage U at cos φ = 0.15



## Protistor® Square-body Fuses PSC aR sizes 3x - 450V to 700 VAC Curves set

### Size 30

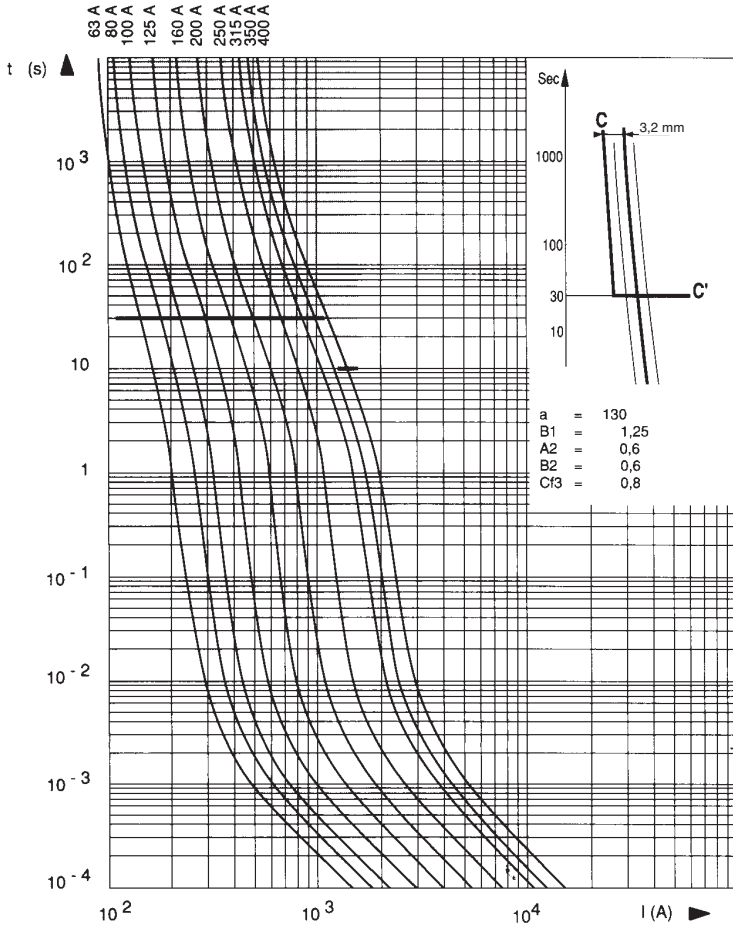

### ↓ Cut-off characteristics

Below, right: Curves indicating for each rated-current the peak value  $I_C$  that the current may reach as a function of the prospective fault current  $I_p$ .

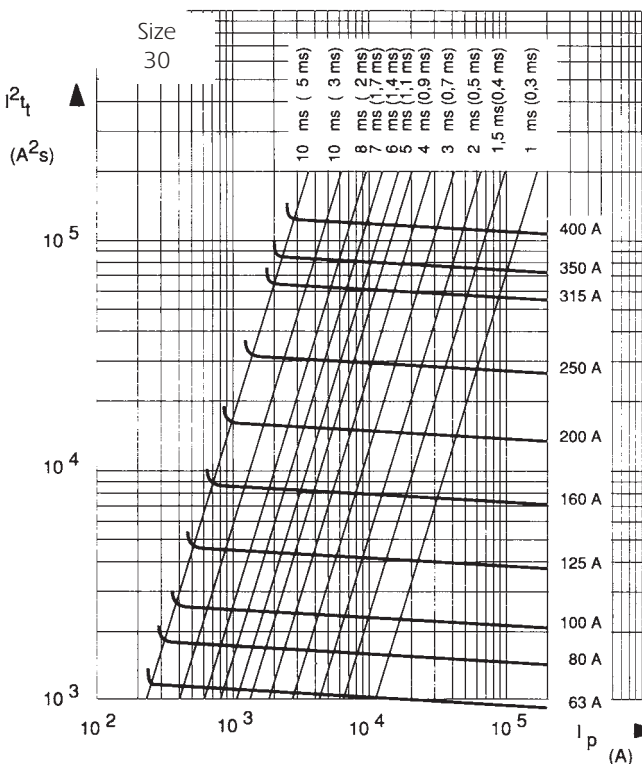
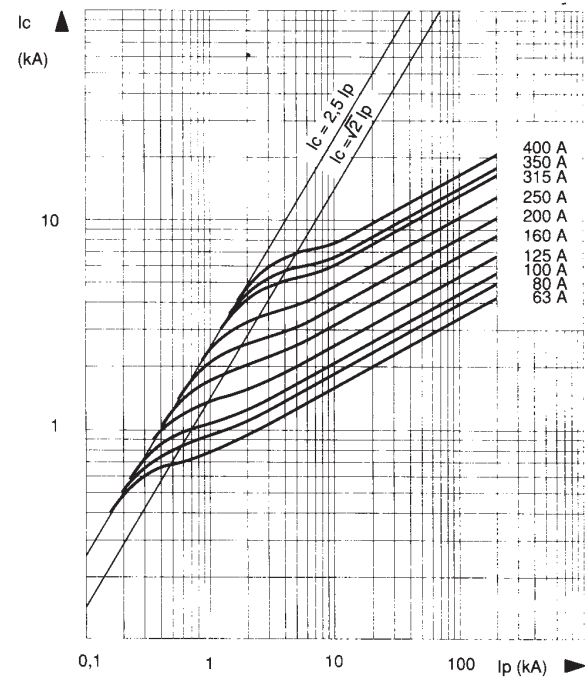

### ↑ Time-current characteristics

Above, left: Curves indicating pre-arcing time for each rated current as a function of RMS value of pre-arcing current  $I$ .

- Tolerances on this current  $\pm 8\%$ .
- Beyond 30 sec or 10 sec, small overloads must be eliminated by another device.
- Curve CC' represents the maximum times taken by the associated device to clear small overloads; only its horizontal line is represented. Its oblique line must be plotted according to sketch, top right corner.
- The intersection of the fuse and CC' curves indicates the minimum breaking current  $I_{pm}$  of the fuse.

### ← Maximum values of total operating $I^2t$ and total operating times

Left: Horizontal curves indicating the maximum values of total operating  $I^2t$  ( $I^2t_t$ ) as function of the prospective current  $I_p$  at 660 V,  $\cos \varphi = 0.15$ . The oblique lines indicate the corresponding total operating time  $T_T$ , with pre-arcing time in brackets.

## Protistor® Square-body Fuses PSC aR sizes 3x - 450V to 700 VAC Curves set

Size 31

### ↓ Cut-off characteristics

Below, right: Curves indicating for each rated current the peak value  $I_C$  that the current may reach as a function of the prospective fault current  $I_P$ .

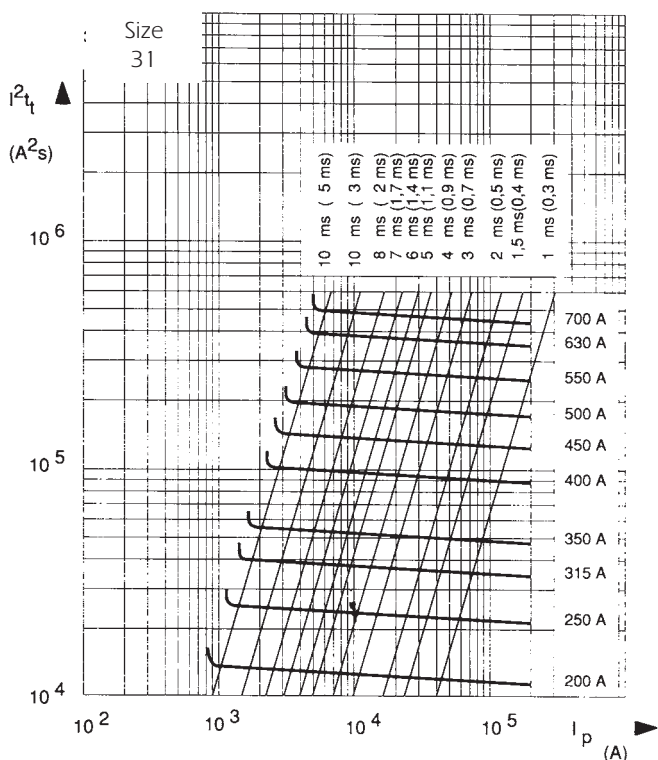
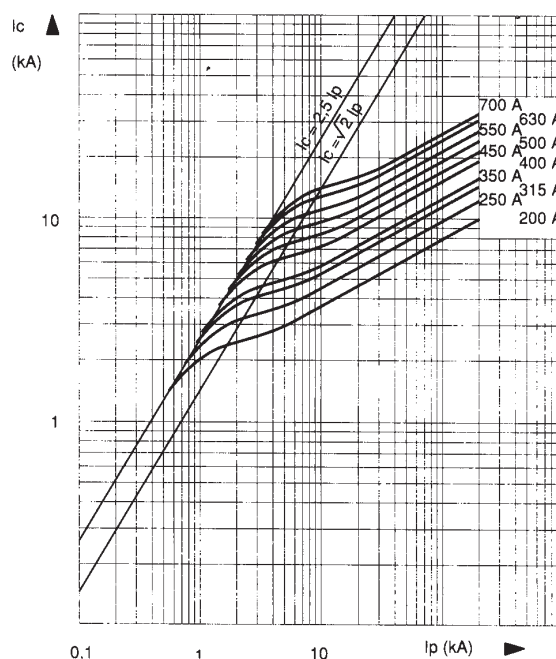
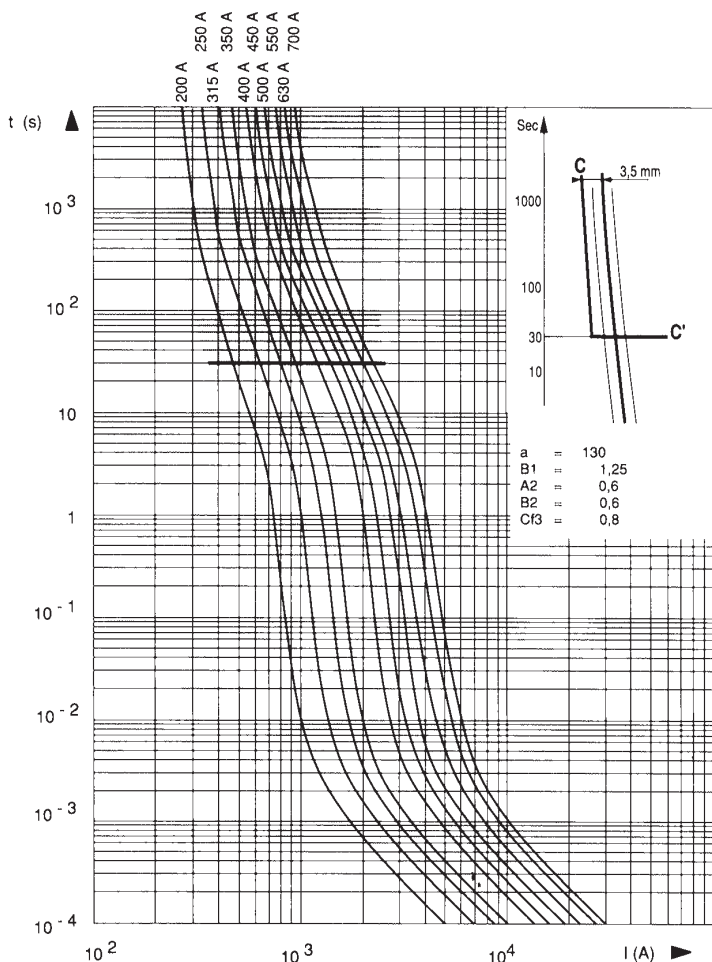

### ↑ Time-current characteristics

Above, left: Curves indicating pre-arcing time for each rated current as a function of RMS value of pre-arcing current  $I$ .

- Tolerances on this current  $\pm 8\%$ .
- Beyond 30 sec or 10 sec, small overloads must be eliminated by another device.
- Curve  $CC'$  represents the maximum times taken by the associated device to clear small overloads; only its horizontal line is represented. Its oblique line must be plotted according to sketch, top right corner.
- The intersection of the fuse and  $CC'$  curves indicates the minimum breaking current  $I_{pm}$  of the fuse.

### ← Maximum values of total operating $I^2t$ and total operating times

Left: Horizontal curves indicating the maximum values of total operating  $I^2t$  ( $I^2t_t$ ) as function of the prospective current  $I_P$  at 660 V,  $\cos \varphi = 0.15$ . The oblique lines indicate the corresponding total operating time  $T_T$ , with pre-arcing time in brackets.



## Protistor® Square-body Fuses PSC aR sizes 3x - 450V to 700 VAC Curves set

### Size 32

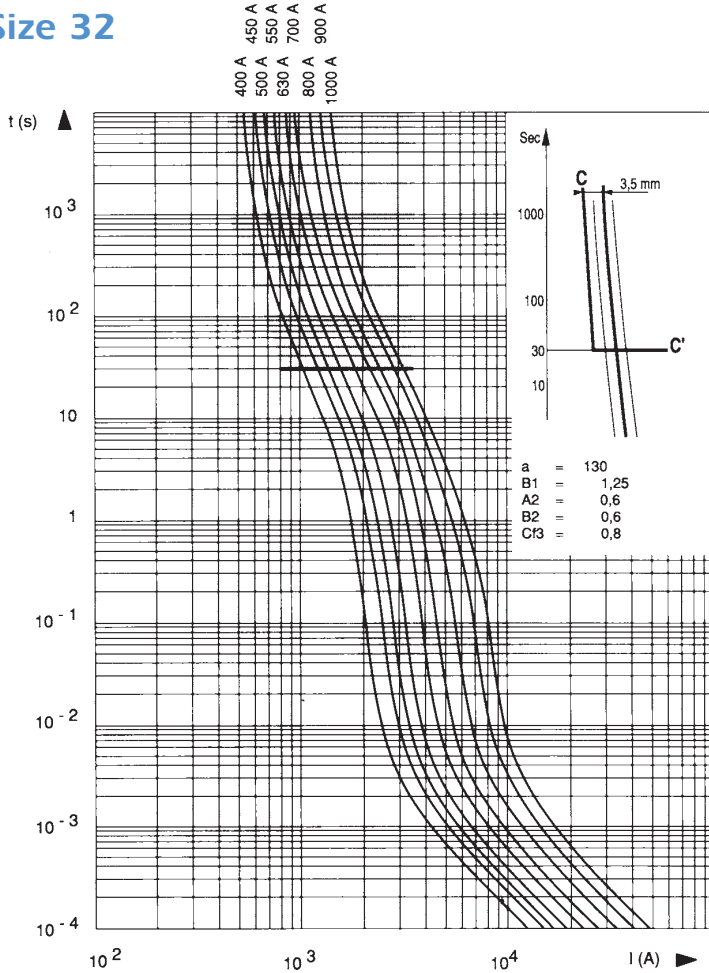

### ↓ Cut-off characteristics

Below, right: Curves indicating for each rated-current the peak value  $I_c$  that the current may reach as a function of the prospective fault current  $I_p$ .

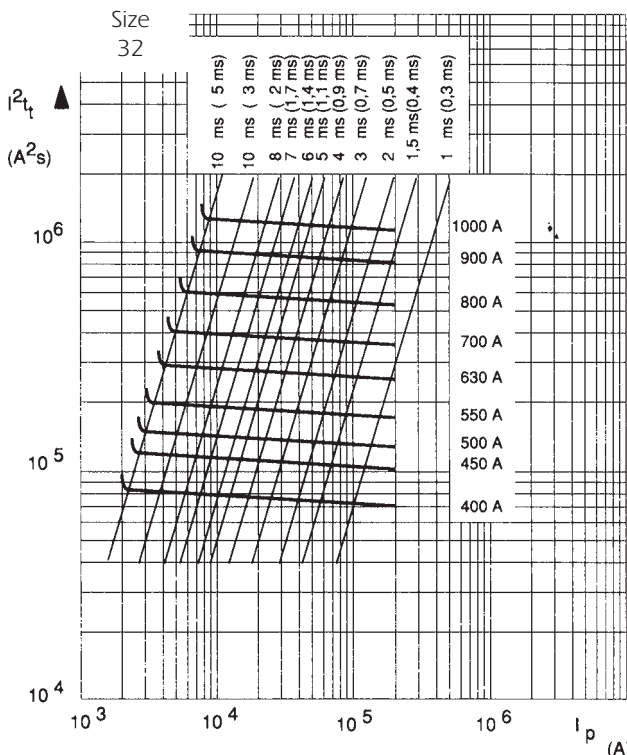
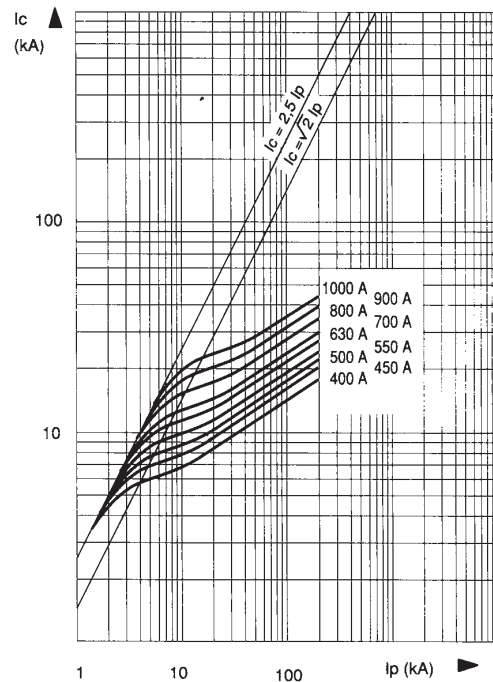

### ↑ Time-current characteristics

Above, left: Curves indicating pre-arcing time for each rated current as a function of RMS value of pre-arcing current  $I$ .

- Tolerances on this current  $\pm 8\%$ .
- Beyond 30 sec or 10 sec, small overloads must be eliminated by another device.
- Curve CC' represents the maximum times taken by the associated device to clear small overloads; only its horizontal line is represented. Its oblique line must be plotted according to sketch, top right corner.
- The intersection of the fuse and CC' curves indicates the minimum breaking current  $I_{pm}$  of the fuse.

### ← Maximum values of total operating $I^2t$ and total operating times

Left: Horizontal curves indicating the maximum values of total operating  $I^2t$  ( $I^2t_t$ ) as function of the prospective current  $I_p$  at 660 V,  $\cos \varphi = 0.15$ . The oblique lines indicate the corresponding total operating time  $T_t$ , with pre-arcing time in brackets.

## Protistor® Square-body Fuses PSC aR sizes 3x - 450V to 700 VAC Curves set

Size 33

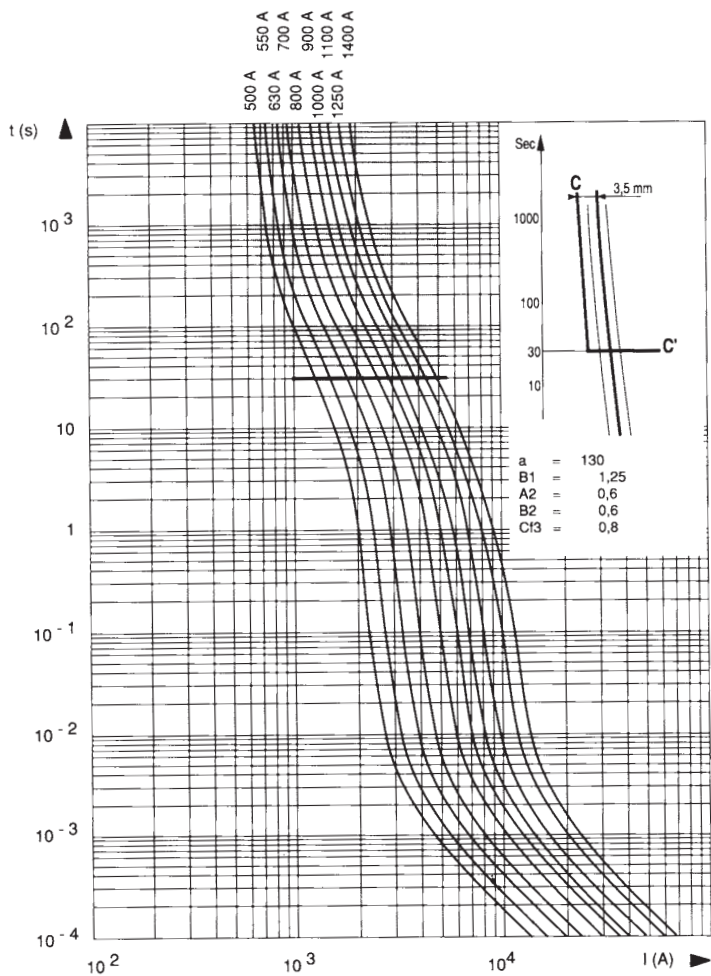

### ↓ Cut-off characteristics

Below, right: Curves indicating for each rated current the peak value  $I_C$  that the current may reach as a function of the prospective fault current  $I_p$ .

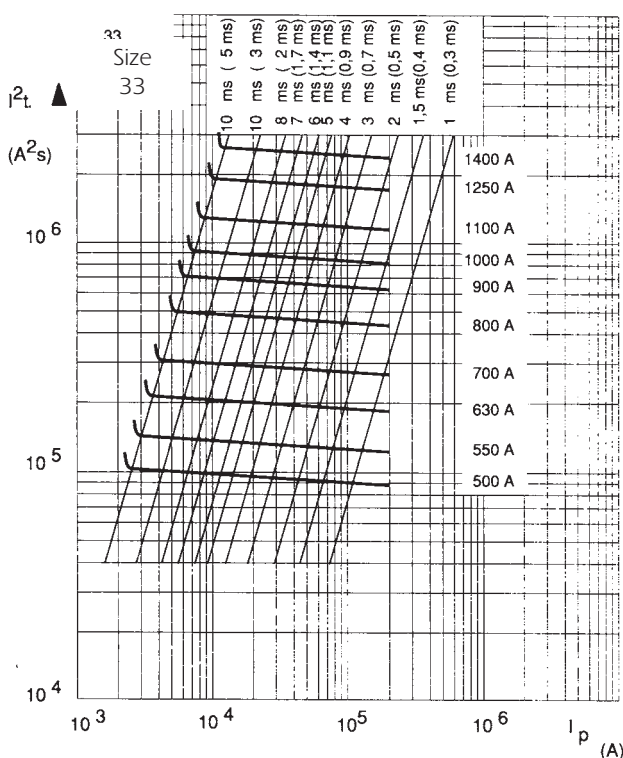
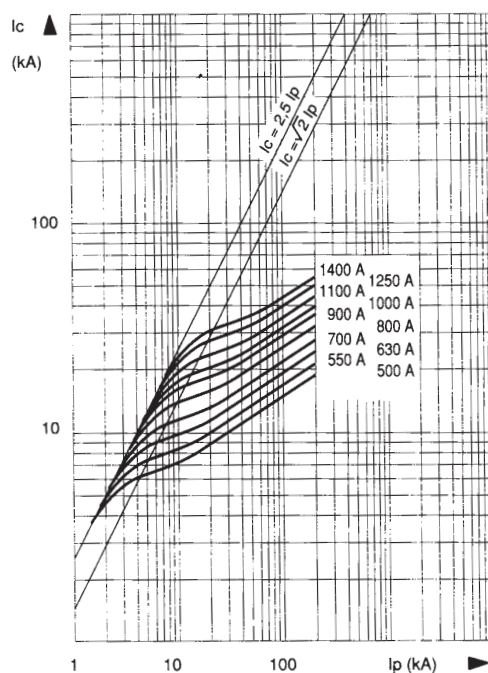

### ↑ Time-current characteristics

Above, left: Curves indicating pre-arcing time for each rated current as a function of RMS value of pre-arcing current  $I$ .

- Tolerances on this current  $\pm 8\%$ .
- Beyond 30 sec or 10 sec, small overloads must be eliminated by another device.
- Curve CC' represents the maximum times taken by the associated device to clear small overloads; only its horizontal line is represented. Its oblique line must be plotted according to sketch, top right corner.
- The intersection of the fuse and CC' curves indicates the minimum breaking current  $I_{pm}$  of the fuse.

### ← Maximum values of total operating $I^2t$ and total operating times

Left: Horizontal curves indicating the maximum values of total operating  $I^2t$  ( $I^2t_t$ ) as function of the prospective current  $I_p$  at 660 V,  $\cos \varphi = 0.15$ . The oblique lines indicate the corresponding total operating time  $T_t$ , with pre-arcing time in brackets.



## Protistor® Square-body Fuses PSC aR sizes 3x - 450V to 700 VAC Curves set

### Sizes 2x32

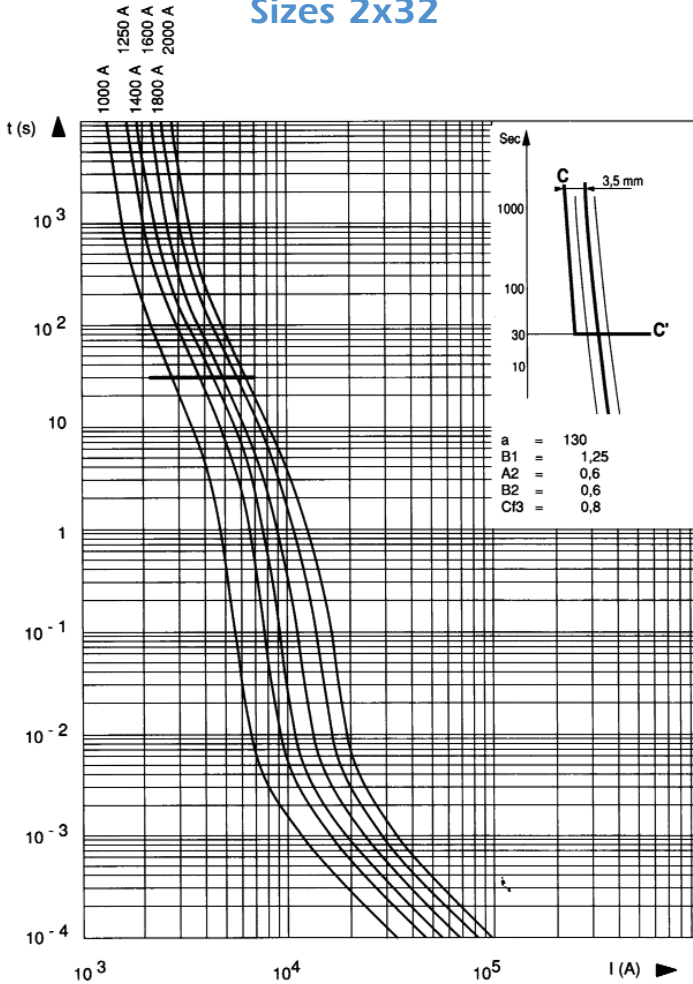

### ↓ Cut-off characteristics

Below, right: Curves indicating for each rated-current the peak value  $I_C$  that the current may reach as a function of the prospective fault current  $I_p$ .

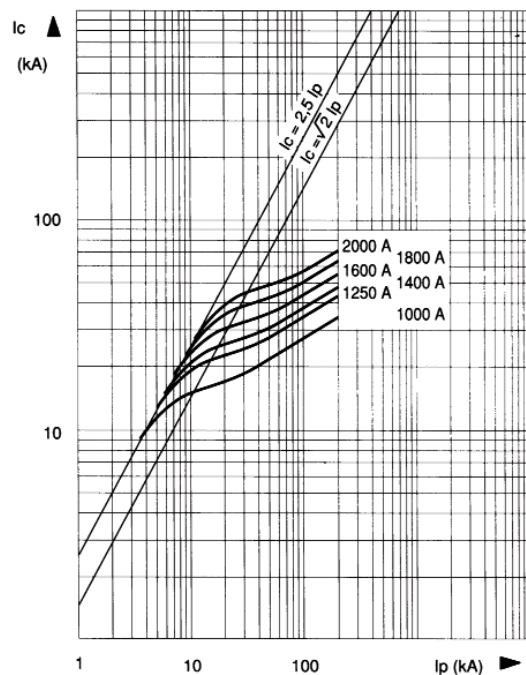

### ↑ Time-current characteristics

Above, left: Curves indicating pre-arcing time for each rated current as a function of RMS value of pre-arcing current  $I$ .

- Tolerances on this current  $\pm 8\%$ .
- Beyond 30 sec or 10 sec, small overloads must be eliminated by another device.
- Curve CC' represents the maximum times taken by the associated device to clear small overloads; only its horizontal line is represented. Its oblique line must be plotted according to sketch, top right corner.
- The intersection of the fuse and CC' curves indicates the minimum breaking current  $I_{pm}$  of the fuse.

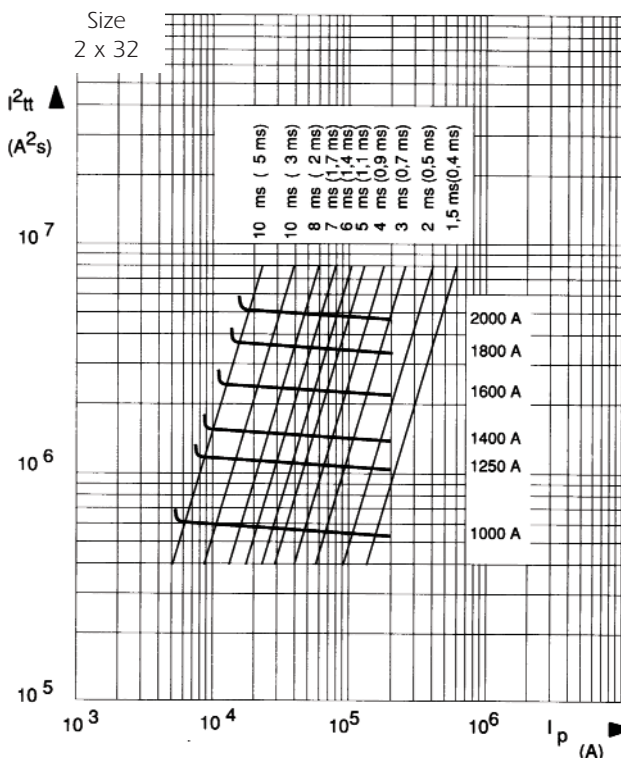

### ← Maximum values of total operating $I^2t$ and total operating times

Left: Horizontal curves indicating the maximum values of total operating  $I^2t$  ( $I^2t_t$ ) as function of the prospective current  $I_p$  at 660 V,  $\cos \varphi = 0.15$ . The oblique lines indicate the corresponding total operating time  $T_t$ , with pre-arcing time in brackets.

## Protistor® Square-body Fuses PSC aR sizes 3x - 450V to 700 VAC Curves set

Size 2x33

### ↓ Cut-off characteristics

Below, right: Curves indicating for each rated current the peak value  $I_C$  that the current may reach as a function of the prospective fault current  $I_p$ .

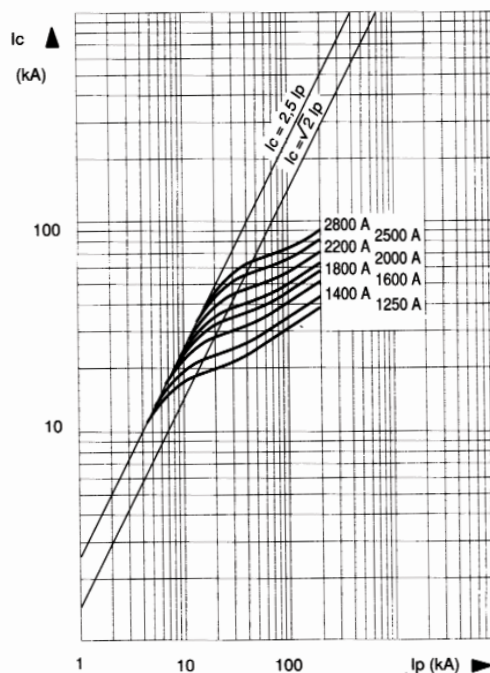
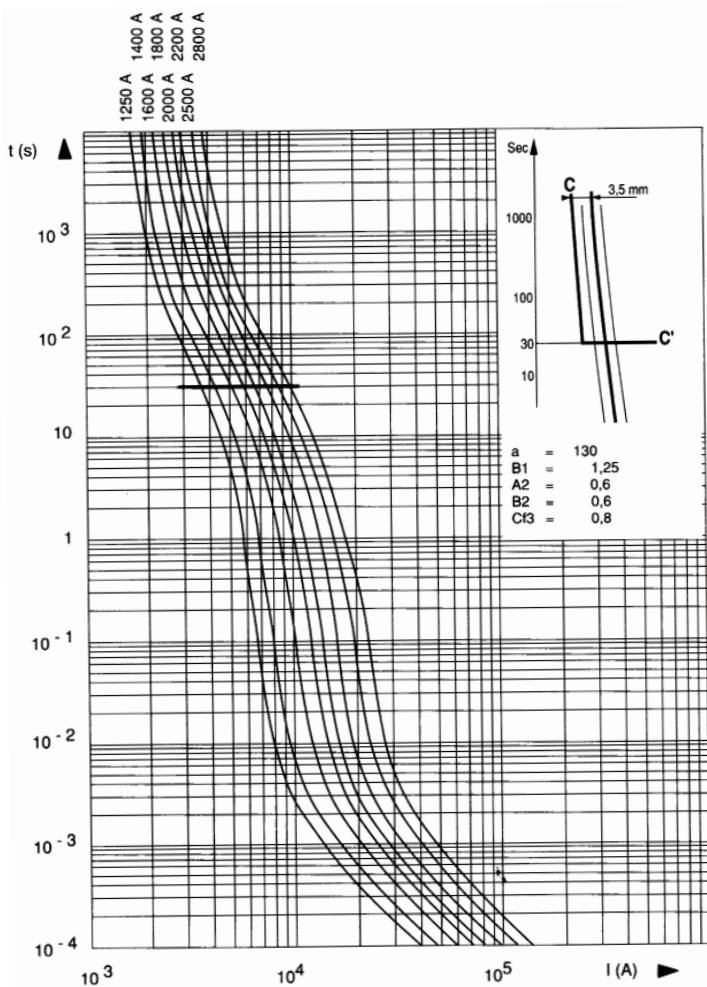

### ↑ Time-current characteristics

Above, left: Curves indicating pre-arcing time for each rated current as a function of RMS value of pre-arcing current  $I$ .

- Tolerances on this current  $\pm 8\%$ .
- Beyond 30 sec or 10 sec, small overloads must be eliminated by another device.
- Curve CC' represents the maximum times taken by the associated device to clear small overloads; only its horizontal line is represented. Its oblique line must be plotted according to sketch, top right corner.
- The intersection of the fuse and CC' curves indicates the minimum breaking current  $I_{pm}$  of the fuse.

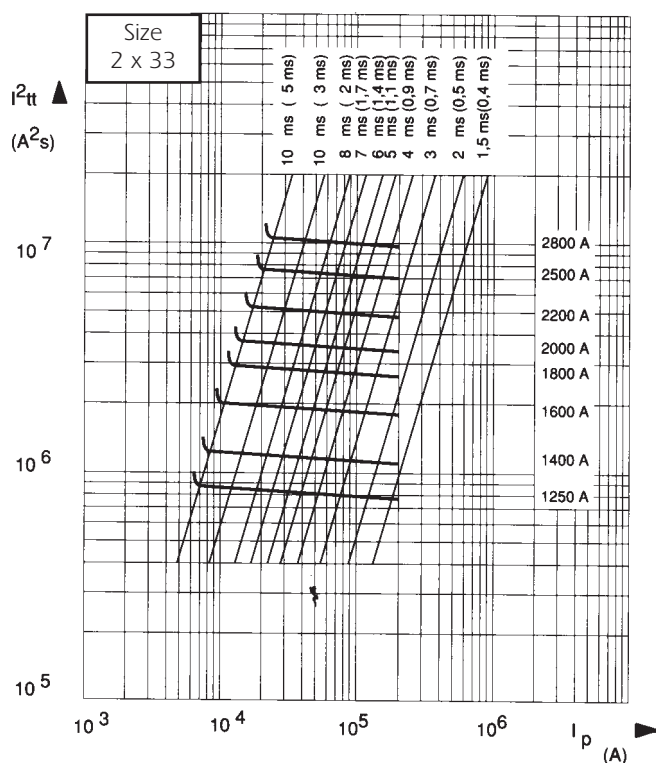

### ← Maximum values of total operating $I^2t$ and total operating times

Left: Horizontal curves indicating the maximum values of total operating  $I^2t$  ( $I^2t_t$ ) as function of the prospective current  $I_p$  at 660 V,  $\cos \varphi = 0.15$ . The oblique lines indicate the corresponding total operating time  $T_t$ , with pre-arcing time in brackets.



## Protistor® Square-body Fuses PSC aR sizes 3x - 450V to 700 VAC Curves set

Sizes 30 - 31 - 32 - 33

### DC working voltage possibilities

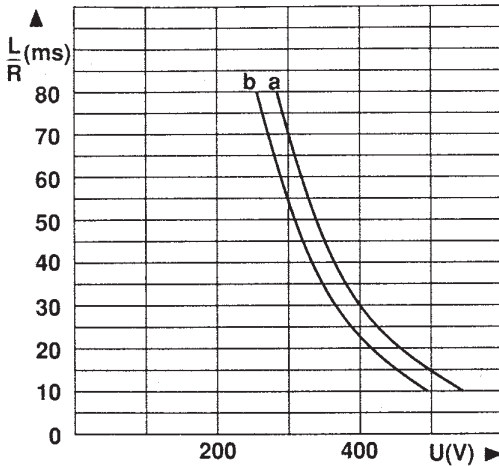

Rated current In (A)	Curves (*) and Ipm (†) corresponding to the rating					
	30 * Ipm (A)	31 * Ipm (A)	32 * Ipm (A)	33 * Ipm (A)	2 x 32 * Ipm (A)	2 x 33 * Ipm (A)
63	a 230					
80	a 300					
100	a 360					
125	a 460					
160	a 650					
200	a 880	a 850				
250	a 1300	a 1150				
315	a 1700	a 1450				
350	a 1900	a 1600				
400	a 2300	a 2200	a 2000			
450		a 2500	a 2300			
500		a 3000	a 2600	a 2300		
550		a 3400	a 3150	a 2500		
630		a 5000	a 3700	a 3250		
700		a 5600	a 4300	a 3900		
800			a 5300	a 4800		
900			a 7800	a 5600		
1000			b 9000	a 6600	a 5200	
1100				a 7700		
1250				b 11000	a 7400	a 6500
1400				b 12500	a 8600	a 7800
1600					a 10600	a 9600
1800					a 15600	a 11200
2000					b 18000	a 13200
2200						a 15400
2500						b 22000
2800						b 25000

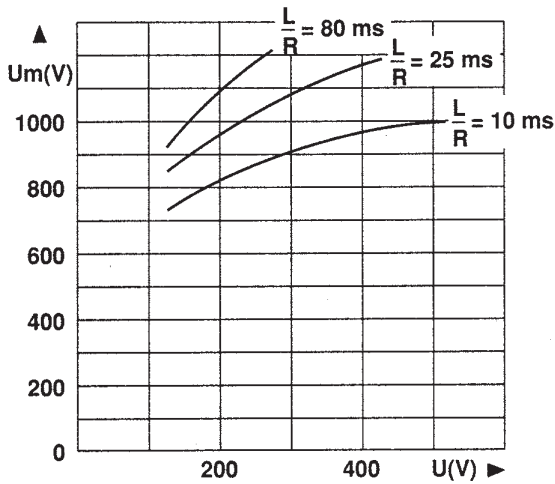

**Top:** Curves indicating the maximum time constant  $L/R$  of the fault path as a function of the DC voltage  $U$  for the rated currents in the sizes indicated in the table.

$I_{pm}$  (†) values indicate the minimum breaking current in Amperes (A).

**Remark:**

When the fault current  $di/dt$  is very large, this condition can be exceeded. This is the case for faults occurring in voltage commutated inverters.

**Below:** Curves indicating peak arc voltage  $U_m$  which may appear across fuse terminals as a function of the DC working voltage  $U$ , for various time constant  $L/R$  of fault path.

## Protistor® Square-body Fuses PSC aR sizes 3x - 450V to 700 VAC Microswitches PSC 3x & 7x

- MICROSWITCH SYSTEMS ADAPTED TO THE FOLLOWING FERRAZ SHAWMUT FUSES ONLY:
- PSC sizes 30, 31, 32, 33, 2x32, 2x33 / 70, 71, 72, 73, 272, 273 except plain blades
- PSC LR sizes 33, 233, 73, 273
- PERMANENT INDICATION OF FUSE STATE: CONDUCTIVE  
BLOWN
- MANUAL RESETTING
- STANDARD AND LOW ELECTRICAL LEVEL WITH DIFFERENT INSULATION LEVELS
- BS TYPE FOR USE IN CORROSIVE ATMOSPHERE
- MS 3V 1-5 UR AND MS 7V 1-5 UR TYPE UL ARE RECOGNIZED



MS 7V 1-5

### Main Characteristics

Code	AC Insulation voltage rating (***)	Positive operating voltage/current	Current rating	Current	Breaking Capacity						AC voltage withstand test (*)	Impulse voltage test Uimp1.2/50 µs (**)	Fire class according to UL 94
					Non inductive circuit			Inductive circuit : L/R = 25ms					
					30V	110V	250V	30V	110V	250V			
MS 3V 1-5	1000 V	20 V 50 mA	10 A	50/60 Hz	10 A	10 A	10 A	10 A	10 A	10 A	8,5 kV	14 kV	H.B
MS 3V 1-5 UR				DC	8 A	0,4 A	0,2 A	4 A	0,2 A	0,1 A			
MS 7V 1-5	1500V	10 V 10 mA	3 A	50/60 Hz	3 A	3 A	3 A	2 A	1 A	1 A	8,5 kV	14 kV	
MS 7V 1-5 UR				DC	3 A	0,5 A	0,25 A	3 A	0,2 A	0,1 A			
MS 3V 1-5 BS	1000 V	10 V 10 mA	3 A	50/60 Hz	3 A	3 A	3 A	2 A	1 A	1 A	8,5 kV	14 kV	
MS 3V 1-9 BS				DC	3 A	0,5 A	0,25 A	3 A	0,2 A	0,1 A			
MS 7V 1-5 BS	1500V	10 V 10 mA	3 A	50/60 Hz	3 A	3 A	3 A	2 A	1 A	1 A	8,5 kV	14 kV	
MS 7V 1-9 BS				DC	3 A	0,5 A	-	2 A	0,2 A	-			
MS 3V 1-5 ET	1000V	10 V	3 A	50/60 Hz	3 A	3 A	3 A	2 A	1 A	1 A	8,5 kV	14 kV	
MS 7V 1-5 ET	1500V	10 mA	3 A	DC	3 A	0,5 A	-	2 A	0,2 A	-	12 kV	20 kV	

\* Between power circuit and microswitch terminals as per IEC 60 and 694 and NFC 64010 (50/60 Hz 1 min duration in dry air)

\*\* Between power circuit and microswitch terminals Uimp: impulse voltage as per IEC 60947-1

\*\*\* Between power circuit and microswitch terminals

**Warning:** microswitch systems exclusively designed for FERRAZ SHAWMUT.  
PSC Fuses fitted a patented trip-indicator, saving use of EDV



## Protistor® Square-body Fuses PSC aR sizes 3x - 450V to 700 VAC Microswitches for PSC 3x & 7x

### Indication systems for PSC Fuse sizes 30 to 73 MS 3V...

These patented indication systems are exclusively hand resettable.

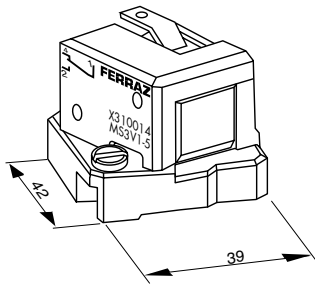

(fig. 1)

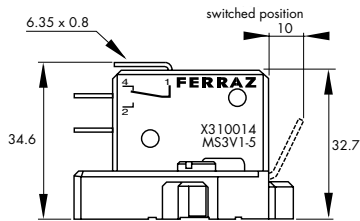

Fuse size	Designation	Ref. Number	Indication style	Weight (g)	Pack.	Catalog Number
30, 31 32, 33	MS 3V 1-5 (fig.1)	X310014	Standard NO-NC	34	3 pieces	MS3 V1-5
	MS 3V 1-5 UR	Y310038				MS3 V1-5UR
	MS 3V 1-5 BS (3)	K310013	Low level NO-NC	34	3 pieces	MS3-V1-5BS
	MS 3V 1-9 BS (4)	P310011	Double pole Low level	44	3 pieces	MS3V1-9BS
	MS 3V 1-5 ET (fig.2)	S310009	Low level NO-NC IP 50 (9)	34	3 pieces	MS3V1-5 ETANCHE

(3) Same as fig.1

(4) Same dimensions as figure 1 but with 2 microswitches side by side

(9) Watertightness class

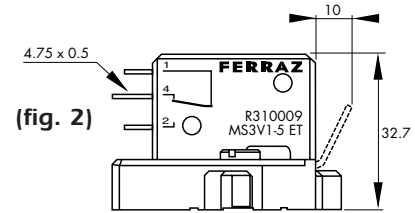

(fig. 2)

### MS 7V...

Fuse size	Designation	Ref. Number	Indication style	Weight (g)	Pack.	Catalog Number
70, 71 72, 73	MS 7V 1-5 (fig.5)	J310002	Standard NO-NC	45	3 pieces	MS7 V1-5
	MS 7V 1-5 UR	Z310039				MS7 V1-5UR
	MS 7V 1-5 BS (3)	K310003	Low level NO-NC	45	3 pieces	MS7-V1-5BS
	MS 7V 1-9 BS (4)	P310007	Double pole Low level	55	3 pieces	MS7V1-9BS
	MS 7V 1-5 ET (fig.6)	S310010	Low level NO-NC IP 50 (9)	55	3 pieces	MS7V1-5 ETANCHE

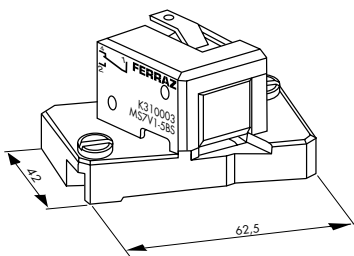

(fig. 5)

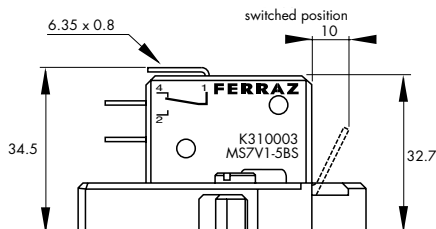

(7) Same as fig. 5

(8) Same dimensions as figure 5 but with 2 microswitches side by side

(9) Watertightness class

**Warning:** Microswitch systems exclusively designed for FERRAZ SHAWMUT PSC fuses fitted with a patented trip-indicator, saving use of EDV.

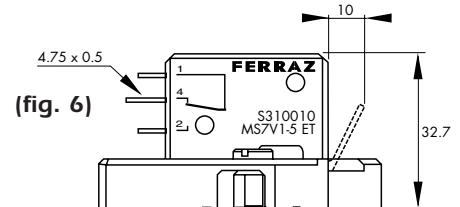



(fig. 6)

# Semiconductor (AC) fuses

## Protistor® Square-body Fuses PSC gR sizes 7x - 690 VAC Metric-studs

### Metric studs for threaded terminal fuses



Type and fuse size	Designation	Ref. Number	Unit weight (g)	Pack.	Catalog Number
 Sizes 0 and 1	HC stud pair M8x30 & M8x35	S098801	23	6 pairs	STU M8x30 M8x35
	Size 2 HC stud pair M10x30 & M10x50	T098802	40	6 pairs	STU M10x30 M10x50
	Size 3 HC stud pair M12x35 & M12x50	V098803	60	6 pairs	STU M12x35 M12x50
 Size 2	HC stud pair M10x50	W098804	45	6 pairs	STU M10x50
	Size 3 HC stud pair M12x50	X098805	45	6 pairs	STU M12x50

We recommend the use of studs, whose quality is suited to all FERRAZ SHAWMUT square-body fuses with terminals

### Stud mounting

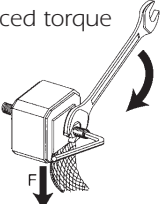
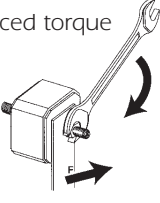
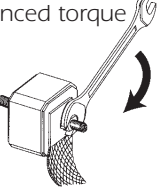
Torque type	Stud type	Maximum stud tightening torque (Nm) (1)	Maximum nut tightening torque (Nm) (1)
Balanced torque 	M8x30 & M8x35	10	13.5
	M10x30 & M10x50	15	26
	M12x35 & M12x50	15	46
Balanced torque 	M8x30 & M8x35	10	13.5
	M10x30 & M10x50	15	26
	M12x35 & M12x50	15	46
Unbalanced torque 	M8x30 & M8x35	10	13.5
	M10x30 & M10x50	15	26
	M12x35 & M12x50	15	46

(1) Factory limit on torque at 20°C ambient: +0, -2Nm; except on 46Nm value (+0, -4Nm)