

Protistor® Square-body Fuses PSC aR sizes 9x - 1500 VAC Main characteristics



Ferraz Shawmut 1500 V PSC fuse-links provide maximum flexibility in equipment design and ultimate protection for today's power conversion equipment. These square body fuse-links are available in three different body sizes, each size having four world-wide acceptable mounting styles. The different mounting styles and body sizes along with a broad range of ampere ratings allow greatest flexibility in equipment design.

The Ferraz Shawmut PSC fuses have been engineered to provide state-of-the-art protection for SCRs, diodes, thyristors, GTO's and IGBT devices. They have pure silver die-cut elements embedded in solidified sand which helps control arcing characteristics for low I^2t and high breaking capacity. All contact surfaces are silver plated and all hardware is non-magnetic.

All fuse links are equipped with a low voltage trip-indicator. This trip-indicator can operate a field mountable microswitch which is easily mounted directly on to the fuse even while in service.

Highlights

- Extremely Fast Acting
- Current Limiting
- Very Low I^2t
- Worldwide Acceptability
- Superior Cycling Ability

Ratings

AC: 100 - 1500A
1500 VAC
200 KA IR

DC: Consult us

Approvals

C: Tested to IEC 60269.4 at UN +10 %

Features/Benefits

Choice of mounting styles gives wide choice for equipment design

Broad range of ampere ratings in a given body size for design flexibility

IEC 60269-4 compliance for fuses for worldwide semiconductor applications

Applications

Protection of rectifiers, inverters, DC drives, UPS Systems, reduced voltage motor starters, and other equipment in globally accepted applications



Protistor® Square-body Fuses PSC aR sizes 9x - 1500 VAC Main characteristics

Voltage (V)	Size	Type	Rating (A)	Maximum I ² t under 1500V (kA ² S)	Power losses in watts				Breaking capacities kA
					End contacts 0,8 In In		Blades 0,8 In In		
1 500 V	91	URF	100	10	18,5	35	18,5	35	1 500 V 200 kA
		URF	125	15	23	43	23	43	
		URF	160	24,5	29	55	29	55	
		URF	180	32,5	33	62	33	63	
		URG	200	50	27,5	52	28	53,5	
		URK	225	78	31	58,5	31	59	
		URH	250	246	25	47	25	47	
		URH	315	384	31	59	31	59	
		URH	350	466	35	66	35	66	
	92	URF	200	40	36,5	69	37,5	71	
		URG	250	84	37,5	73	39	76	
		URK	315	144	46	91	46,5	95	
		URK	350	200	51	101	52	106	
		URH	400	669	41,5	83	44	90	
		URH	500	983	50,5	101	53,5	109	
		URH	550	1 190	57,5	115	61	124	
	93	URF	250	60	48	95	49,5	98	
		URF	315	94	61	120	62	123	
		URF	350	135	67	133	69	137	
		URG	375	185	62	125	64,5	130	
		URK	400	240	60	122	61,5	128	
		URK	450	305	67	137	69	144	
		URK	500	375	77	158	79	165	
		URH	630	1 570	62,5	125	67	136	
		URJ	700	2 500	67	131	73	143	
	2X92	URB	750	3 000	73	143	80	156	
		URG	500	335	77,5	152			
		URK	630	576	93	190			
		URK	700	800	104	212			
		URH	800	2 680	87	177			
		URH	1 000	3 930	106	216			
	2X93	URH	1 100	4 760	120	246			
		URG	750	740	129	260			
		URK	800	960	122	256			
		URK	900	1 220	138	288			
		URK	1 000	1 500	160	332			
		URH	1 250	6 280	131	268			
		URJ	1 400	10 000	143	280			
	URB	1 500	12 000	148	310				

Protistor® Square-body Fuses PSC aR sizes 9x - 1500 VAC French End contacts

Size	Designation	Reference Number	Weight (g)	Packaging	Catalog Number
91	15 URF 91 TTF 0100	W 076 149	650	1	PC91UF15C100TF
	15 URF 91 TTF 0125	X 076 150			PC91UF15C125TF
	15 URF 91 TTF 0160	Y 076 151			PC91UF15C160TF
	15 URG 91 TTF 0200	A 076 153			PC91UG15C200TF
	15 URK 91 TTF 0225	B 076 154			PC91UK15C225TF
	15 URH 91 TTF 0250	C 076 155			PC91UH15C250TF
	15 URH 91 TTF 0315	D 076 156			PC91UH15C315TF
	15 URH 91 TTF 0350	E 076 157			PC91UH15C350TF
92	15 URF 92 TTF 0200	F 076 158	900	1	PC92UF15C200TF
	15 URG 92 TTF 0250	G 076 159			PC92UG15C250TF
	15 URK 92 TTF 0315	H 076 160			PC92UK15C315TF
	15 URK 92 TTF 0350	J 076 161			PC92UK15C350TF
	15 URH 92 TTF 0400	K 076 162			PC92UH15C400TF
	15 URK 92 TTF 0400	M 076 003			PC92UK15C400TF
	15 URH 92 TTF 0500	V 076 194			PC92UH15C500TF
	15 URH 92 TTF 0550	L 076 163			PC92UH15C550TF
93	15 URF 93 TTF 0230	L 097 829	1250	1	PC93UF15C230TF
	15 URF 93 TTF 0250	M 076 164			PC93UF15C250TF
	15 URF 93 TTF 0315	N 076 165			PC93UF15C315TF
	15 URF 93 TTF 0350	P 076 166			PC93UF15C350TF
	15 URG 93 TTF 0375	Q 076 167			PC93UG15C375TF
	15 URK 93 TTF 0400	R 076 168			PC93UK15C400TF
	15 URK 93 TTF 0450	J 076 092			PC93UK15C450TF
	15 URK 93 TTF 0500	T 076 170			PC93UK15C500TF
	15 URH 93 TTF 0630	V 076 171			PC93UH15C630TF
	15 URJ 93 TTF 0700	W 076 172			PC93UJ15C700TF
	15 URB 93 TTF 0750	X 076 173			PC93UB15C750TF

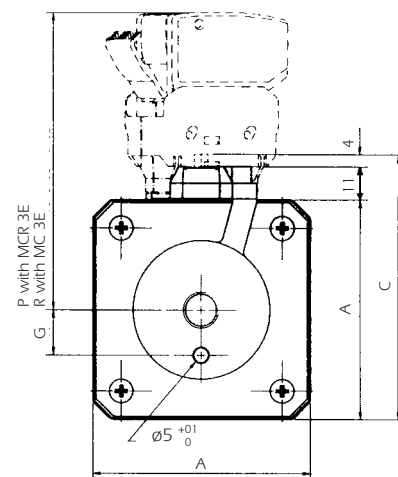
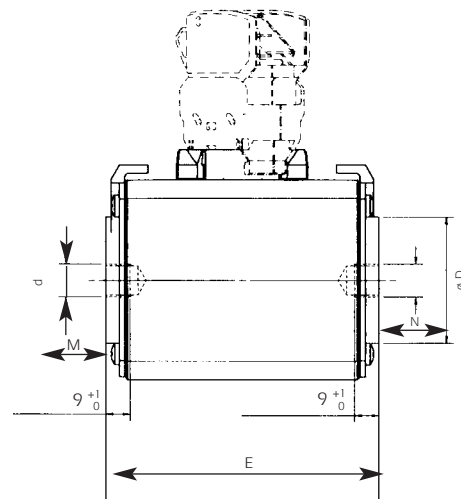

Microswitches : MC3E1-5N - Ref. D310020

MC3E1-5NBS - Ref. E310021

MC3E1-9NBS - Ref. F310022

MC3E1-5NET - Ref. L310027

MCR3E1-5N - Ref. G310023

MCR3E1-5NBS - Ref. P310030

MCR3E1-9NBS - Ref. H310024

MCR3E1-5NET - Ref. Q310031

For operating voltage
1250 VAC - DC max.

Insulation voltage 2200 VAC - DC

Threaded studs and microswitches supplied separately

Size	A	C	D	M [±]	N [±]	E ^{±1,7}	d	G ^{±0,1}	P	R
91	51	66	30	19	24	101	M8	9	87,5	72,5
	2"	2,6"	1-3/16"			3,98"		23/64"	3,45"	2,85"
92	60	74	38	19	39	101	M10	15	91,5	76,5
	2-3/8"	2,95"	1-1/2"			3,98"		19/32"	3,6"	3"
93	74,5	88	46	24	39	101	M12	15	98,5	83,5
	2-15/16"	3,5"	1-13/16"			3,98"		19/32"	3,9"	3,29"

Note : dimensions in mm and inches

M and N dimensions are with Metric studs Ref. Number S098801 for size 91 T098802 for size 92 and V098803 for size 93.

Maximum balanced nut tightening torque: 13,5 Nm (M8) - 26 Nm (M10)

46 Nm (M12)

Protistor® Square-body Fuses PSC aR sizes 9x - 1500 VAC French End contacts

Size	Designation	Reference Number	Weight (g)	Packaging	Catalog Number
2x92	15 URG 292 TTF 0500	Y 076 174	2460	1	PC292UG15C500TF
	15 URK 292 TTF 0630	Z 076 175			PC292UK15C630TF
	15 URK 292 TTF 0700	A 076 176			PC292UK15C700TF
	15 URH 292 TTF 0800	B 076 177			PC292UH15C800TF
	15 URH 292 TTF 1000	C 076 178			PC292UH15C10CTF
	15 URH 292 TTF 1100	D 076 179			PC292UH15C11CTF
2x93	15 URG 293 TTF 0750	P 081 755	3450	1	PC293UG15C750TF
	15 URK 293 TTF 0800	F 076 181			PC293UK15C800TF
	15 URK 293 TTF 0900	G 076 182			PC293UK15C900TF
	15 URK 293 TTF 1000	Q 081 756			PC293UK15C10CTF
	15 URH 293 TTF 1250	R 081 757			PC293UH15C13CTF
	15 URJ 293 TTF 1400	S 081 758			PC293UJ15C14CTF
	15 URB 293 TTF 1500	X 081 854			PC293UB15C15CTF

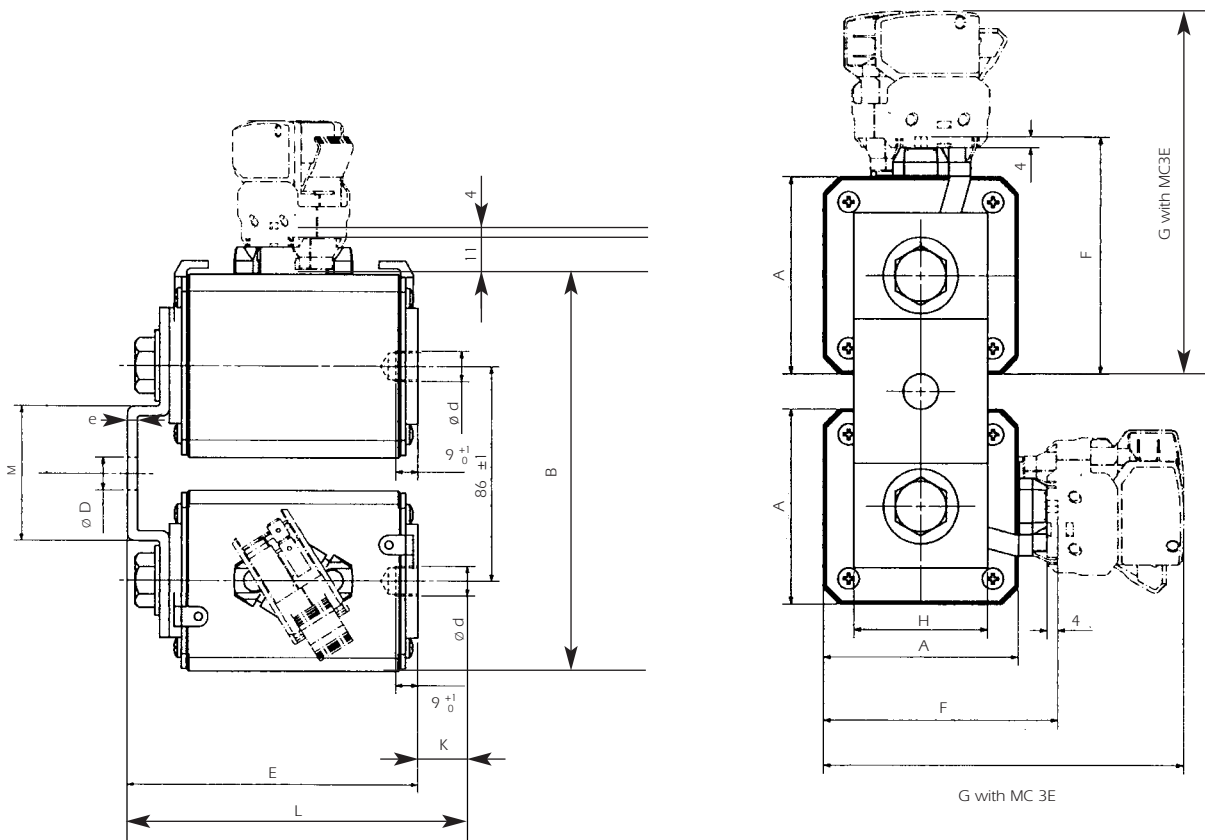

Threaded studs and microswitches supplied separately

Size	A	B	D	E ^{±1.7}	F	G	H	K	d	e	L	M	N
2x92 TT	60	147	11	118	74	106,5	35	40	M10	4	158	48	72
2x93 TT	74,5	164	13	118	88	121	50	40	M12	4	158	54	86

Dimensions in mm

K dimensions are with studs Ref. Number W098804 in size 2x92 and X098805 in size 2x93.

Maximum balanced nut tightening torque: 26 Nm (M10) and 46 Nm - (M12)

Semiconductor (AC) fuses

Protistor® Square-body Fuses PSC aR sizes 9x - 1500 VAC Curves set

I²t corrective K factor

URF/URG/URK

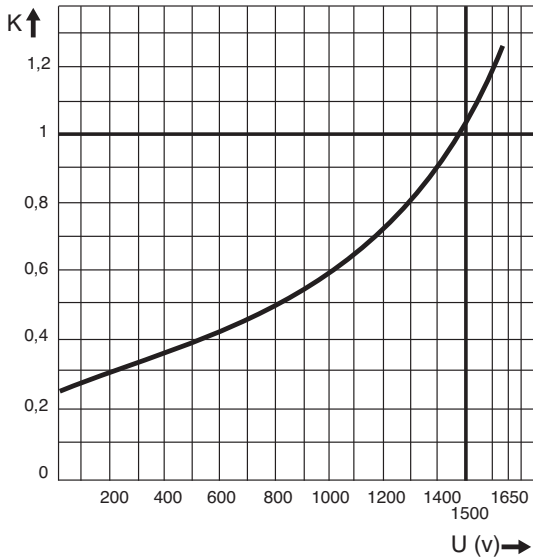

URB/URH/URJ

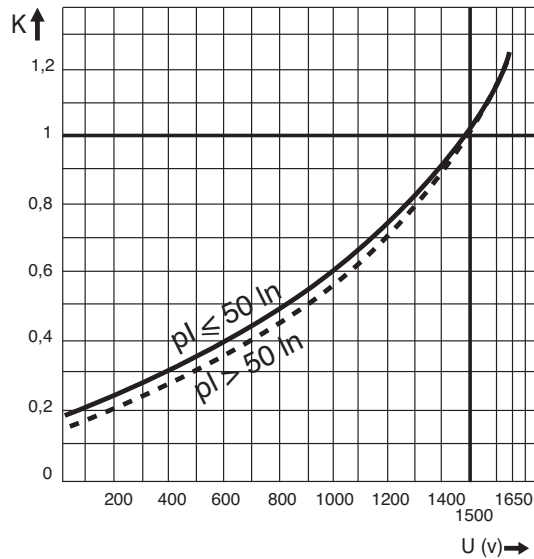

U: R.M.S. working voltage V
K: I²t corrective coefficient versus U

pl: Prospective Current in the fuse

Arc voltage

URF/URG/URK

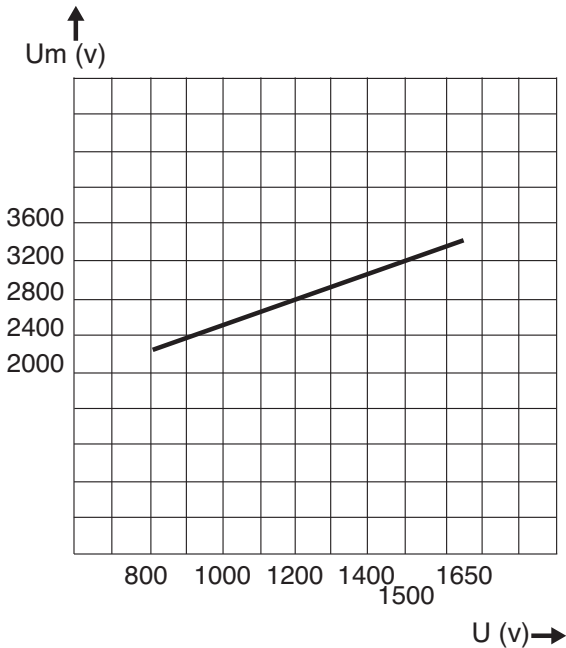

URB/URH/URJ

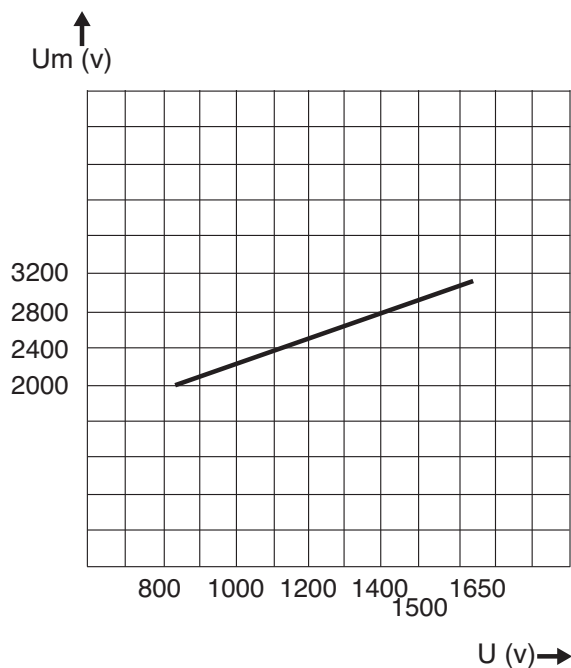

Um: arc voltage
U: R.M.S. working voltage V

Protistor® Square-body Fuses PSC aR sizes 9x - 1500 VAC Curves set

Times/Current Characteristics

URF

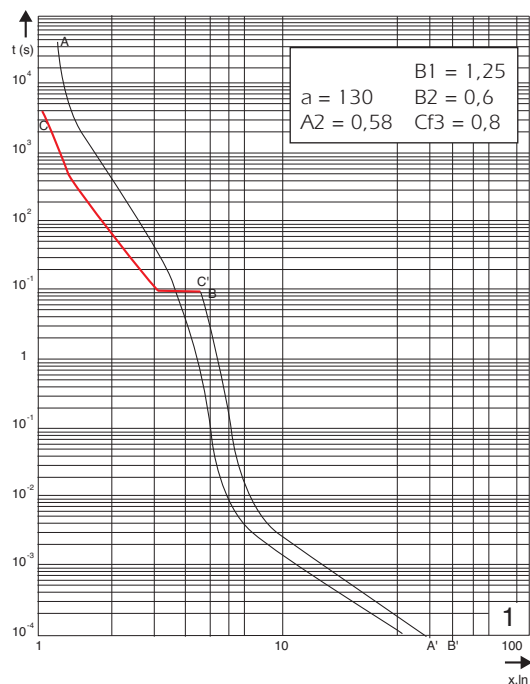

URG

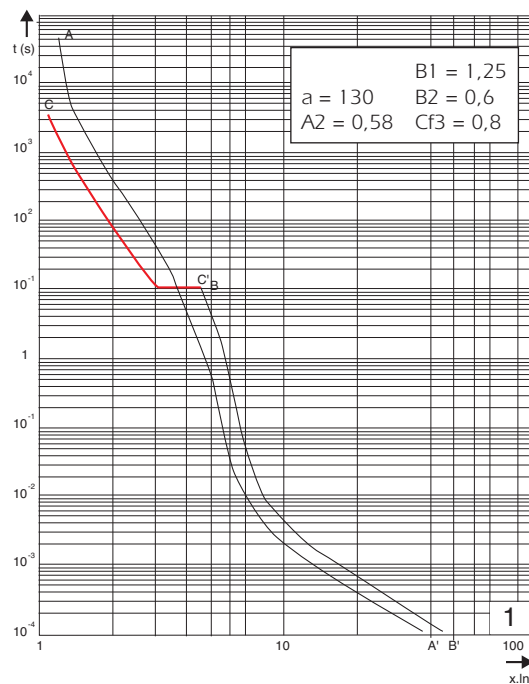

t: actual prearcing time (s) (average value)
x:In: R.M.S. value of prearc current in multiples of rated current

URK

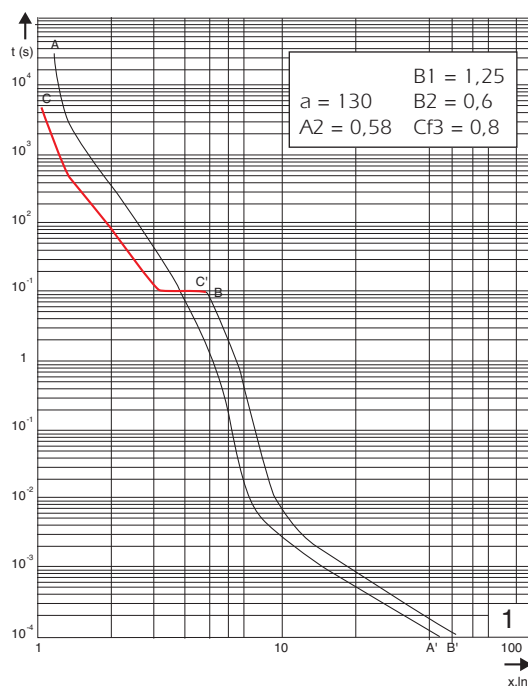

Semiconductor (AC) fuses

Protistor® Square-body Fuses PSC aR sizes 9x - 1500 VAC Curves set

URB

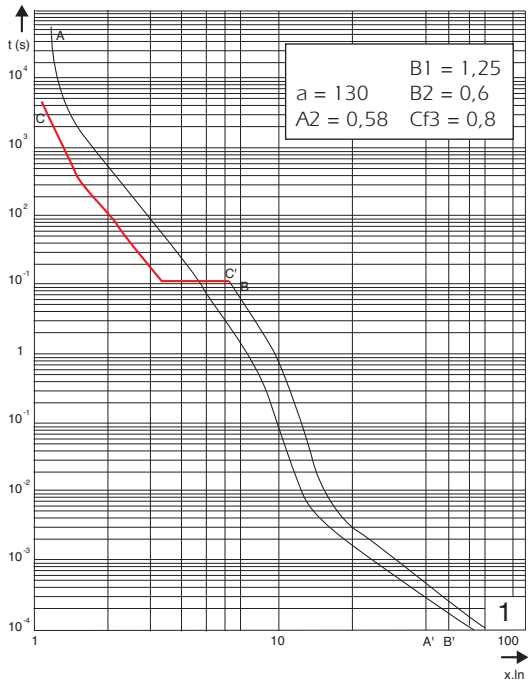

URH

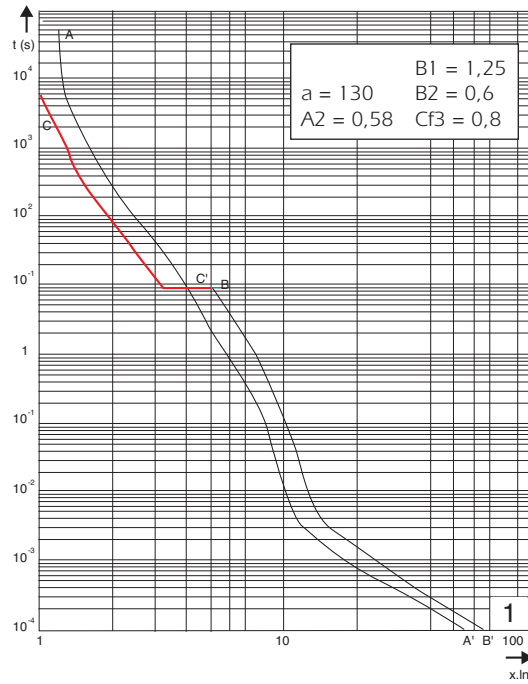

URJ

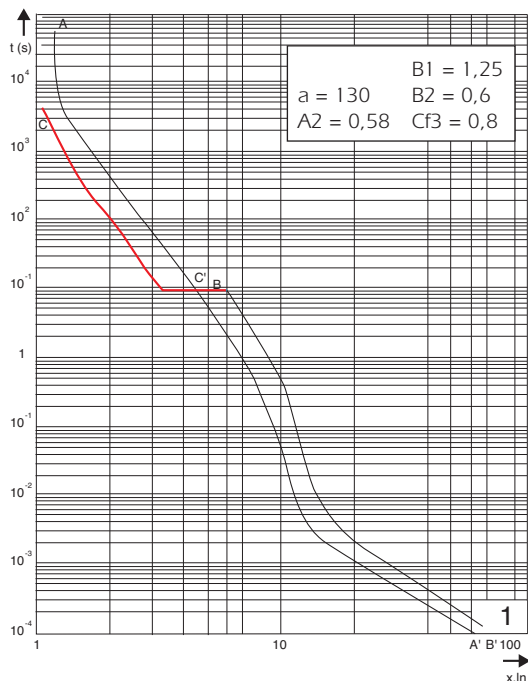

Protistor® Square-body Fuses PSC aR sizes 9x - 1500 VAC Microswitches for other square-body Protistor®



- REMOTE SIGNALING SYSTEMS FOR FITTING ON FERRAZ SHAWMUT FUSES EQUIPPED WITH MICROSWITCH SUPPORT: all square-body sizes 44 / 8X / 9X / 12X / 17X / 30X and 60X
- PERMANENT INDICATION OF FUSE STATE
 - CONDUCTIVE
 - BLOWN
- MANUAL RESETTING
- STANDARD AND LOW ELECTRICAL LEVEL WITH DIFFERENT INSULATION LEVELS
- VAPOR AND WATERTIGHT MODEL FOR USE IN CORROSIVE ATMOSPHERE

Main Characteristics

Type	Designation	AC or DC Insulation voltage rating U_i (V)	AC voltage withstand test (*)	Impulse voltage test $U_{imp1,2/50}$ μ s (**)	Positive operating min. voltage /min. current	Current rating	Interrupting rating							
							Current	Non-inductive circuit			Inductive circuit: L/R = 25ms			
								30V	110V	250V	30V	110V	250V	
Standard	MC3E 1-5N	1250V	15 kV	20 kV	20 V 50 mA	5 A	50/60 Hz	10 A	10 A	7 A			6 A	
	MCR3E 1-5N	2200	20 kV	30 kV			DC	5 A	0.5 A			1,6 A	0,3 A	
Low level	MC3E 1-5NBS	1250 V	15 kV	20 kV	10 V 10 mA	3 A	50/60 Hz	3 A	3 A	3 A	2 A	1 A	1 A	
	MC3E 1-9NBS							2200 V	20 kV (1)	30 kV	3 A	3 A	3 A	2 A
	MCR3E 1-5NBS	6000 V	23 kV (2)	40 kV			DC		3 A		0.5 A	0.25A	3 A	0.2 A
	MCR3E 1-9NBS		24 kV (1)											
Watertight IP 50	MC2R3E 1-5NBS	6000 V	26 kV (2)	40 kV	10 V 10 mA	3 A	50 Hz	3 A	3 A		1 A	1 A		
	MC2R3E 1-9NBS		32 kV (3)											
	MC3E 1-5NET		11 kV					16 kV	3 A	0.5 A		0,2 A		
	MCR3E 1-5NET	2200 V	20 kV (1)	30 kV			DC							
	MC2R3E 1-5NET	6000 V	24 kV (2)	40 kV										

Catalog Numbering system: MC3E 1-5 single pole microswitch - MC3E 1-9 double pole microswitch - MCR, MC2R reinforced insulation microswitch.

* Between power circuit and microswitch terminals as per IEC 60 and 694 and NFC 64010 (50/60 Hz 1 min duration in dry air).

** Between power circuit and microswitch terminals U_{imp} : impulse voltage according to IEC 947-1.

*** Between power circuit and microswitch terminals

(1) fitting sizes 44 - 70 - 71 - 72 - 73 - 83 - 84 fuses.

(2) fitting sizes 91 - 92 - 93 - 94 -120 - 121 - 122 - 123 - 124 fuses.

(3) fitting sizes 171 - 172 - 173 - 174 - 300 - 302 - 600 - 602 fuses.

Semiconductor (AC) fuses

Protistor® Square-body Fuses

PSC aR sizes 9x - 1500 VAC

Microswitches for other square-body Protistor®

Remote signaling with 1250 V AC/DC insulation voltage

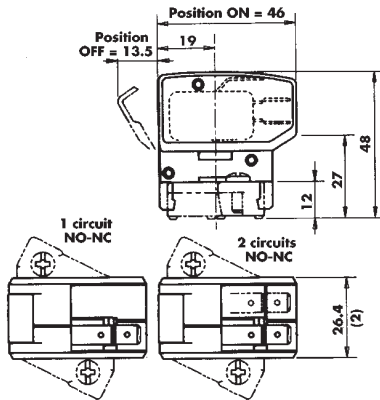

Quantity of NO-NC separated circuits	Contact	Designation	Ref. Number	Weight (g)	Pack. (1)	Catalog Number
1	standard	MC3E 1-5N	D310020	39.5	3	MC3E1-5N
1	low level	MC3E 1-5NBS	E310021	39.5	3	MC3E1-5NBS
2	low level	MC3E 1-9NBS	F310022	45.7	3	MC3E1-9NBS
1	watertight	MC3E 1-5NET	L310027	40.2	3	MC3E1-5N ETANCHE

Remote signaling with insulation voltage up to 2200 V AC/DC

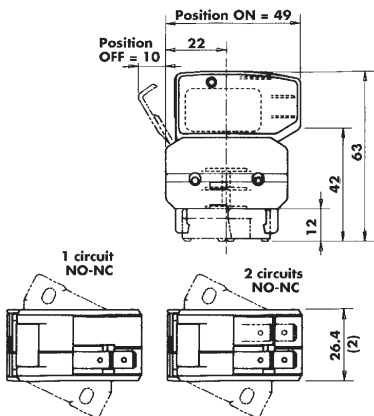

Quantity of NO-NC separated circuits	Contact	Designation	Ref. Number	Weight (g)	Pack. (1)	Catalog Number
1	standard	MCR3E 1-5N	G310023	51.7	1	MCR3E1-5N
1	low level	MCR3E 1-5NBS	P310030	51.7	1	MCR3E1-5NBS
2	low level	MCR3E 1-9NBS	H310024	58.0	1	MCR3E1-9NBS
1	watertight	MCR3E 1-5NET	Q310031	52.5	1	MCR3E1-5N ETANCHE

Remote signaling with insulation voltage up to 6000 V AC/DC

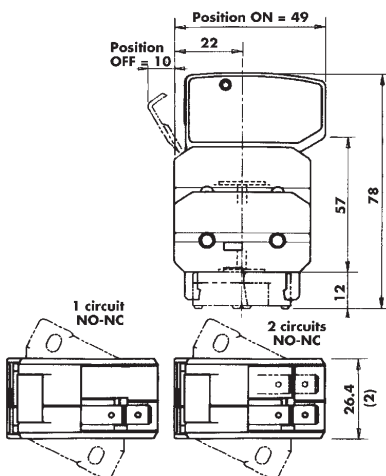

Quantity of NO-NC separated circuits	Contact	Designation	Ref. Number	Weight (g)	Pack. (1)	Catalog Number
1	low level	MC2R3E 1-5NBS	J310025	64.0	1	MC2R3E1-5NBS
1	watertight	MC2R3E 1-5NET	N310029	64.8	1	MC2R3E1-5NET
2	low level	MC2R3E 1-9NBS	K310026	70.3	1	MC2R3E1-9NBS

Electrical diagram of each microswitch circuit

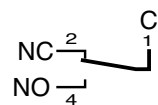

Non-blown fuse
Microswitch ON

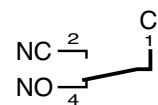

Blown fuse
Microswitch OFF

All of these signalling systems are hand resettable and fitted with silver-plated 3-terminal microswitch C, NO and NC.

The C terminal is on the top and connection is made via 6.35 mm clips except for watertight models whose clips are 4.8 mm wide.

NOTE (2): The 26.4 dimension is the same with 1 or 2 separated circuits NO-NC.

Tests with sine vibrations carried out at ambient with scanning of the three main holder axes.

Spectrum: 1st segment (2 to 16 Hz) constant trip $x = 5$ mm peak.

2nd segment (16 to 250 Hz) constant acceleration $g = 5$ g peak.



Exponential scanning speed : 1 octave per minute.

Duration: 2 hours per axis.

Protistor® Square-body Fuses PSC aR sizes 3x - 450V to 700 VAC Metric-studs

Metric studs for threaded terminal fuses



Type and fuse size	Designation	Ref. Number	Unit weight (g)	Pack.	Catalog Number
 Sizes 0 and 1 Size 2 Size 3	HC stud pair M8x30 & M8x35	S098801	23	6 pairs	STUM8x30M8x35
	HC stud pair M10x30 & M10x50	T098802	40	6 pairs	STUM10x30M10x50
	HC stud pair M12x35 & M12x50	V098803	60	6 pairs	STUM12x35M12x50
 Size 2 Size 3	HC stud pair M10x50	W098804	45	6 pairs	STUM10x50
	HC stud pair M12x50	X098805	45	6 pairs	STUM12x50

We recommend the use of studs, whose quality is suited to all FERRAZ SHAWMUT square-body fuses with terminals

Stud mounting

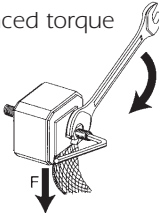
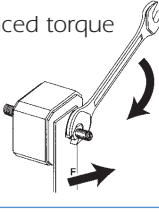
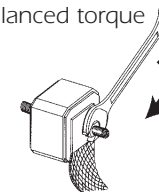
Torque type	Stud type	Maximum stud tightning torque (Nm) (1)	Maximum nut tightning torque (Nm) (1)
Balanced torque 	M8x30 & M8x35	10	13.5
	M10x30 & M10x50	15	26
	M12x35 & M12x50	15	46
Balanced torque 	M8x30 & M8x35	10	13.5
	M10x30 & M10x50	15	26
	M12x35 & M12x50	15	46
Unbalanced torque 	M8x30 & M8x35	10	13.5
	M10x30 & M10x50	15	26
	M12x35 & M12x50	15	46