

DC Square-body Fuses Sizes 600 - 602 - 2x602 gR Brackets size 2x302 - 4000 V DC

gRB-gRD from 200 to 560 A

Dimensions

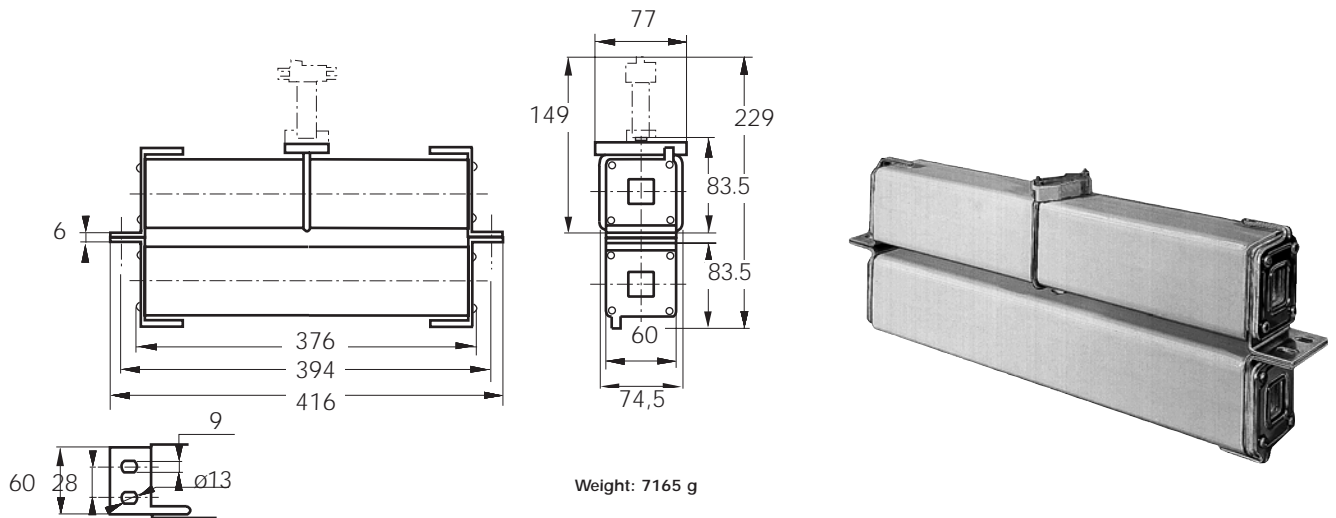

Main Characteristics

Size	Current rating I_N (A)	Breaking Capacity	Watts loss		Designation	Ref. Number	Catalog Number
			$0.8 I_N$ (W)	I_N (W)			
2x602	200	@ 4000 V DC	109	200	CC 40 gRB 2x602 QF 200M	R086955	D2602GB40C200QF
	250	30 kA L/R = 30 ms	138	254	CC 40 gRB 2x602 QF 250M	S086956	D2602GB40C250QF
	315	@ 4000 V DC 30 kA L/R = 15 ms	126	231	CC 40 gRD 2x602 QF 315M	J075770	D2602GD40C315QF
	400		153	282	CC 40 gRD 2x602 QF 400M	K075771	D2602GD40C400QF
	500		190	348	CC 40 gRD 2x602 QF 500M	L075772	D2602GD40C500QF
	560		216	396	CC 40 gRD 2x602 QF 560M	M075773	D2602GD40C560QF

Pack: 1 piece

Microswitch MC 2R 3E 1-5NBS Ref. Number: J310025

DC Square-body Fuses Sizes 600 - 602 - 2x602 gR Brackets size 2x302 - 4000 V DC

gRB-gRD from 200 to 560 A

Electrical characteristics DC applications data

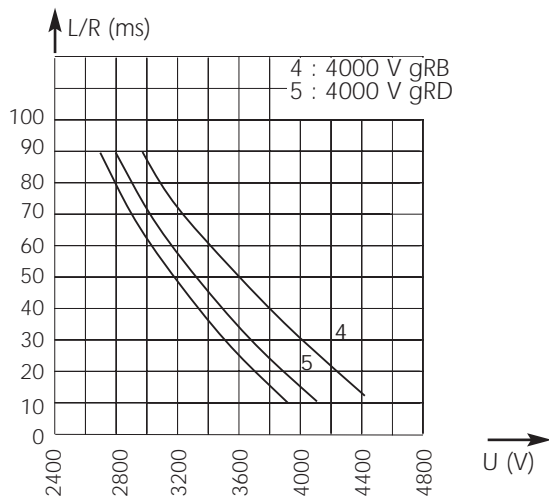

Above: Curves indicate maximum permissible value of time constant L/R as a function of DC working voltage

Max. AC voltage (50/60 Hz):
 3600 V with breaking capacity of 30 kA

Time vs. current characteristics

Peak arc voltage vs. working voltage

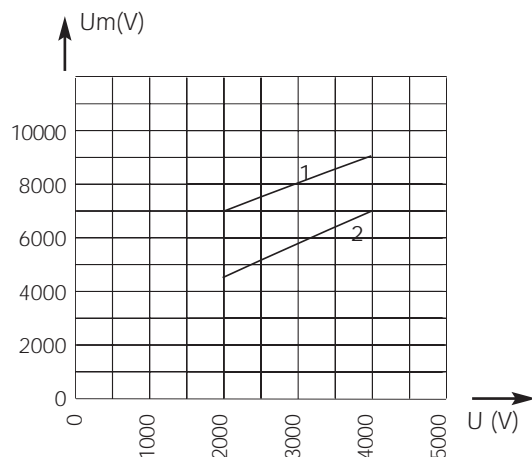

1 : $L/R = 30$ ms 4000 V gRB
 2 : $L/R = 15$ ms 4000 V gRD

Above: Curves indicate for various time constants L/R the peak arc voltage which may appear across fuse terminals, vs. DC working voltage

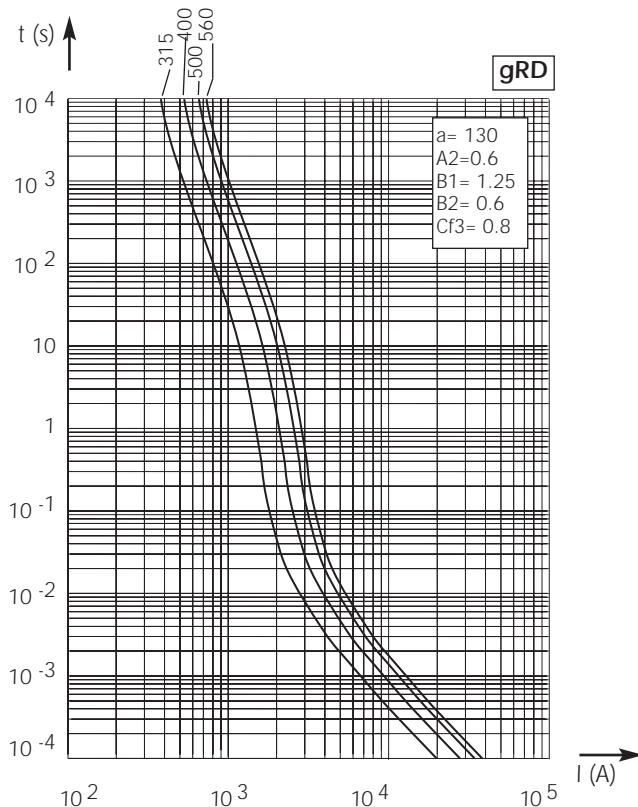
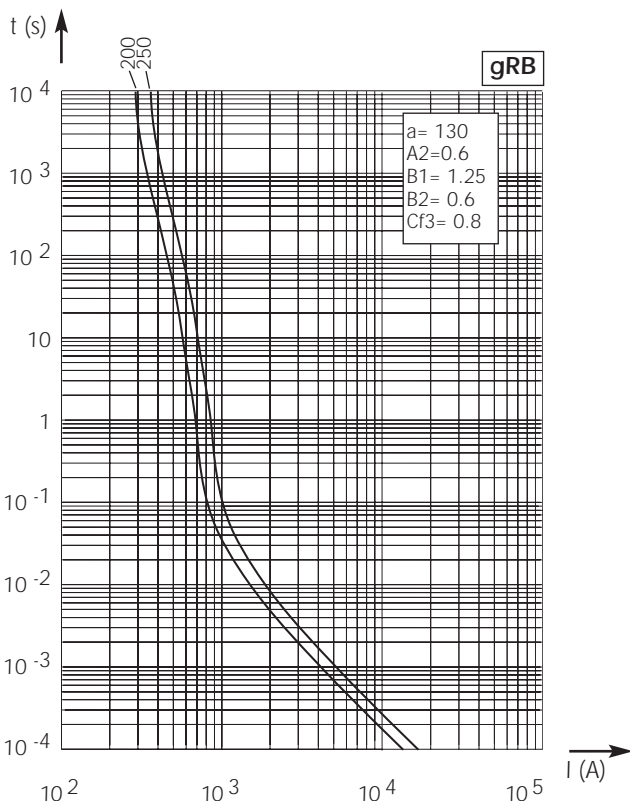

Above, left and right: Curves indicate, for each rated current, pre-arcing time vs. R.M.S. pre-arcing current

$\pm 10\%$ tolerance for mean pre-arcing current