

## DC Square-body Fuses Sizes 600 - 602 - 2x602 gR Brackets size 602 - 4000 V DC

gRB-gRD from 100 to 280 A

### Dimensions

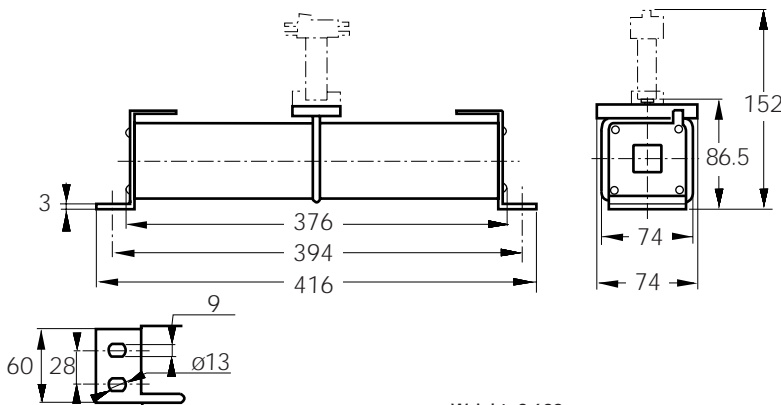

Weight: 3,600 g



### Main Characteristics

Size	Current rating $I_N$ (A)	Breaking Capacity	Watts loss		Designation	Ref. Number	Catalog Number
			$0.8 I_N$ (W)	$I_N$ (W)			
602	100	@ 4000 V DC	55.6	100.8	CC 40 gRB 602 QF 0100	V086958	D602GB40C100QF
	125	30 kA	72.4	131.1	CC 40 gRB 602 QF 0125	W086959	D602GB40C125QF
	160	L/R = 30 ms	84.8	153.6	CC 40 gRB 602 QF 0160	X086960	D602GB40C160QF
	160	@ 4000 V DC	58	101	CC 40 gRD 602 QF 0160	E075766	D602GD40C160QF
	200	30 kA	76.5	141	CC 40 gRD 602 QF 0200	F075767	D602GD40C200QF
	250	L/R = 15 ms	95	174	CC 40 gRD 602 QF 0250	G075768	D602GD40C250QF
	280		108	198	CC 40 gRD 602 QF 0280	H075769	D602GD40C280QF

Pack: 1 piece

Microswitch MC 2R 3E 1-5NBS Ref. Number: J310025



## DC Square-body Fuses Sizes 600 - 602 - 2x602 gR Brackets size 602 - 4000 V DC

gRB-gRD from 100 to 280 A

### Electrical characteristics DC applications data

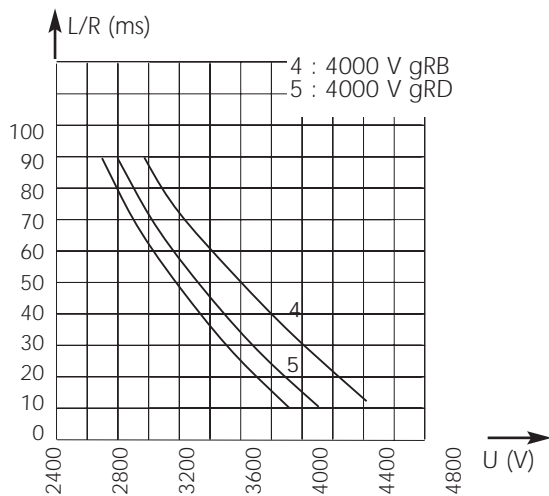

Above: Curves indicate maximum permissible value of time constant  $L/R$  as a function of DC working voltage

Max. AC voltage (50/60 Hz):  
 3600 V with breaking capacity of 30 kA

### Time vs. current characteristics

### Peak arc voltage vs. working voltage

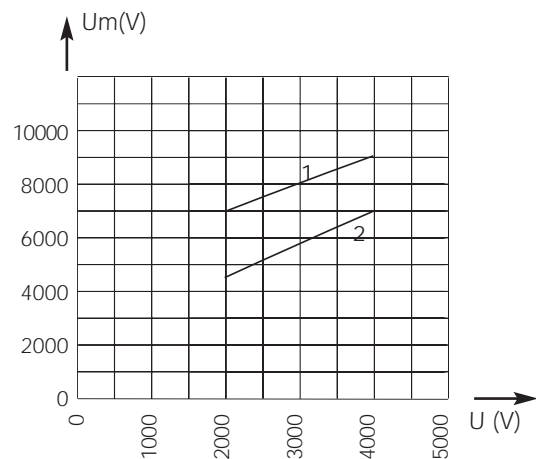

1 :  $L/R = 30$  ms 4000 V gRB  
 2 :  $L/R = 15$  ms 4000 V gRD

Above: Curves indicate for various time constants  $L/R$  the peak arc voltage which may appear across fuse terminals, vs. DC working voltage

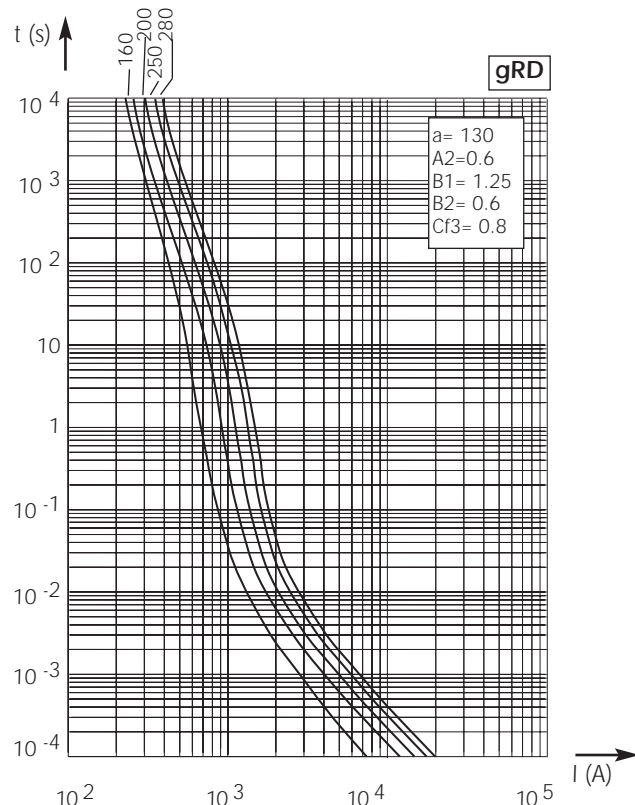
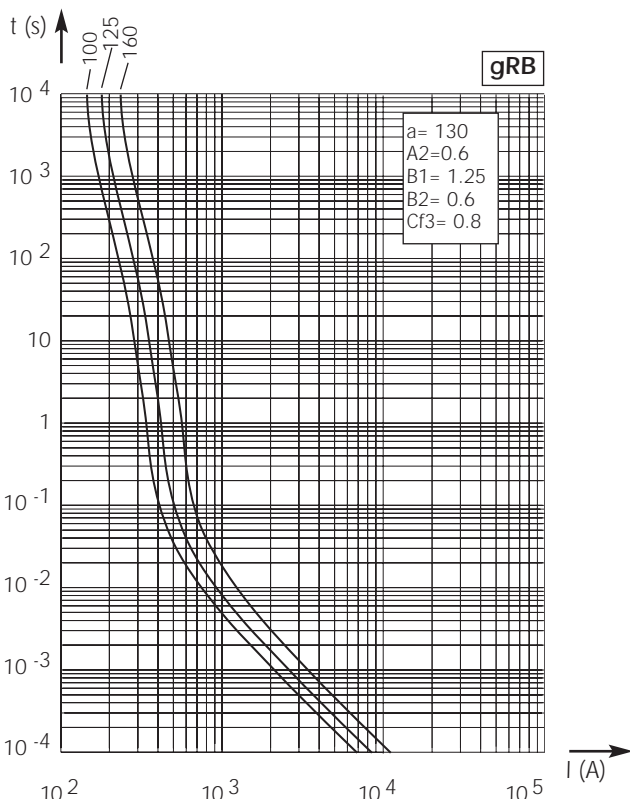

Above, left and right: Curves indicate, for each rated current, pre-arcing time vs. R.M.S. pre-arcing current

$\pm 10\%$  tolerance for mean pre-arcing current