

## MV Fault Indicator Linetroll 3600



Directional fault current indicator for overhead lines

### Présentation

LINETROLL 3600 directional Fault Current Indicators (FCI) are designed to help the operator locate faults on overhead lines. They detect both single phase-to-ground (PTG) and phase-to-phase (PTP) faults in systems with 300A impedance or compensated neutral grounding. And they use a brand-new detection technique that offers significant advantages over the conventional technique of existing detectors working on current thresholds. That new technology means that unlike conventional detectors, they can operate on systems with high capacitive current (combined overhead/underground networks with a high proportion of cable).

The LINETROLL 3600 FCI is capable of discriminating between PTP and PTG faults, and indicating the direction of the latter type.

It can be used on networks from 6 to 132 kV for the following applications:

**LINETROLL 3600 PDAC:** installed on strategic points in the network (switching points, branching points), it assists the operator by visually signaling the passage of a single- or multi-phase fault current.

**LINETROLL 3600 PDAT:** when used in combination with remote-controlled switchgear, it assists the operator in remote control by providing contacts that alert the remote control system to the passage of a PTG or PTP fault current.

**LINETROLL 3600 PDAU:** installed temporarily on a disturbed network, it identifies what sections are responsible for faults and gives a time and date system the data required to analyze faults, whether persistent or transient.

# Medium voltage fuses

## MV Fault Indicator Linetroll 3600

### Description and working principle

The LINETROLL 3600 works on the principle of directional fault indication described in EDF patent 9209549. The following block diagram shows the LINETROLL 3600 indicator's main circuits.

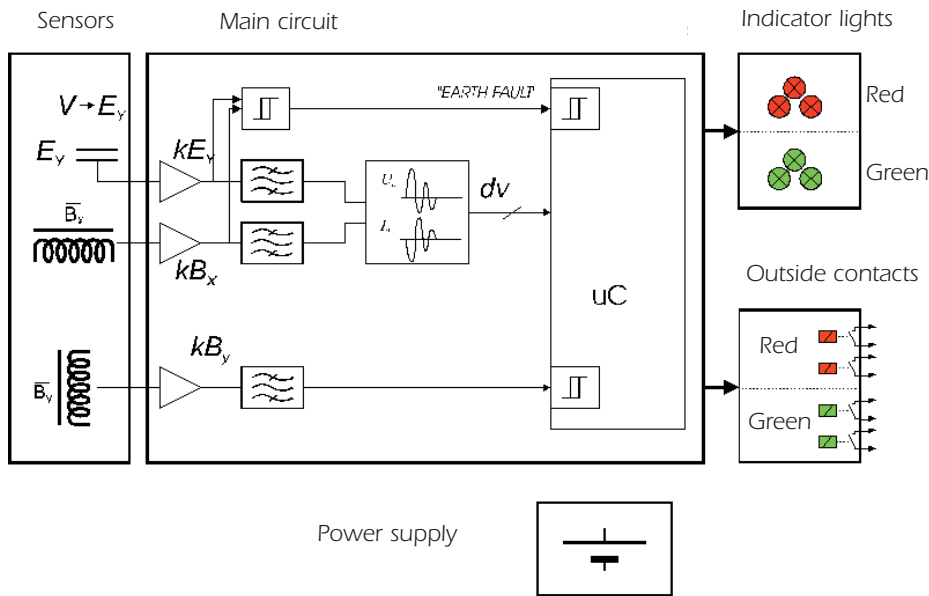

In the initial milliseconds after a PTG fault, voltage and current transients are generated on the system. Using a microprocessor to interpret the phase displacement between residual voltage and residual current, the circuit can indicate in which direction the PTG fault is located (up-line or down-line of the support the pole is strapped to).

For PTP faults the working principle is that of an ammeter (current threshold).

There are 5 standard models:

Function	Power supply	Outside connections	Designations	References number	Catalog number
Assistance in operation	Batteries (power for 4 years in operation)	None	LINETROLL 3600 PDAC	P 210762	LT3600PDAC
Assistance in operation with counter Requires remote control unit COMTROLL 360 W210768	Batteries (power for 4 years in operation)	None	LINETROLL 3600 PDAC counter	V 210997	LT3600PDAC-CP
Assistance in remote operation	12 VDC	Outside contacts provided to transmit indicator light data	LINETROLL 3600 PDAT	Q 210763	LT3600PDAT
Assistance in operation with counter Requires remote control unit COMTROLL 360 W210768	12 VDC	Outside contacts provided to transmit indicator light data	LINETROLL 3600 PDAT Counter	T 210996	LT3600PDAT-CP
Diagnosis Requires remote control unit COMTROLL 360 W210768	Batteries (power for 4 years in operation)	Connection to a time and date system provided	CABLETROLL 3600 PDAU	R 210764	LT3600PDAU

## MV Fault Indicator Linetroll 3600

### Application of a LINETROLL 3600 FCI

#### General

When a LINETROLL 3600 detects a fault current, it alerts the operator either visually with a signal light or through contacts (LINETROLL 3600 AT or AU).

As soon as the existence of a fault is confirmed, the signal light on the LINETROLL 3600 lights up and stays lit until one of the following events occurs:

- Forward voltage returns to the HV line (voltage reset).
- The internal 2 hour time delay ends (timer reset).
- The operator resets the fault indicator using either the "manual" system on the box or the COMTROLL infrared remote control unit (manual reset). The device can be reset manually by turning the display unit to the signal light reset position and then turning it back to its original position.

#### PTG fault indication

The principle of directional PTG fault indication is to locate what part of the line is the origin of a PTG fault. To do this, the LINETROLL 3600 PTG fault indicator has two signal lights:

- A **Red** light on the front of the box
- A **Green** light on the back, on the side where the device is supported.

If the **GREEN** signal light is lit up, the fault is on the **GREEN** side, i.e. the side of the support.

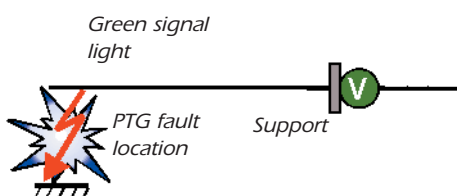

If the **RED** signal light is lit up, the fault is on the **RED** side, i.e. the side opposite the support.

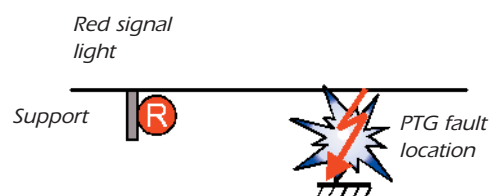

#### PTP fault indication

In this case the LINETROLL 3600 FCI works like a conventional fault indicator and no direction is indicated. All the fault indicators between the feeding substation and the fault flash the green signal light and the red signal light alternately (once every second).



# Medium voltage fuses

## MV Fault Indicator Linetroll 3600

### Fault indication characteristics

Sensitivities are defined in the reference set-up shown below.  
Please inquire for any other set-up desired.

#### PTG faults

Any PTG fault characterized by a residual current over 60A peak + 10A and a residual voltage of 9kV + 2kV is detected. Once those thresholds are exceeded, the fault indicator waits 40 ms to detect a residual voltage  $V_r$  greater than 3.5kV + 0.5kV before indicating that there is indeed a fault.

#### PTP faults

Any PTP fault characterized by a current over 450Arms + 80A is detected.

#### Double PTG faults

A fault considered as a "double PTG fault" consists of a simultaneous PTG fault on two different phases in a system powered by the same HV transformer but grounded at two geographically distant points. The two faults may be located on the same feeder or on two different feeders. In this case any fault characterized by a residual current over 250Arms + 50A is detected.

#### Return of forward voltage

The return of forward HV voltage (resetting the FCI) is accepted when voltage on the system is at least 10kVrms + 2kV.

### FCI construction

The LINETROLL 3600 FCI consists of four parts:

- A support to be strapped on the pole with a metal strip. That support may have openings for wiring to connect the device to other equipment and a connection to a time and date system.
- A main box containing the sensors, the electronic boards and the batteries.
- A display unit on the bottom of the box. That display unit may be rotated 90° to improve visibility if required. It is also used to reset and test the fault indicator.
- A top cap screwed onto the main box. That cap may be equipped with an optional solar panel to power the FCI.

