

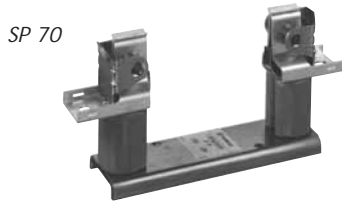

Semiconductor Fuses AC+DC Square-boby Fuse Bases Bases for other Blade Fuses - Size 30 to 123: SE, SP, SF

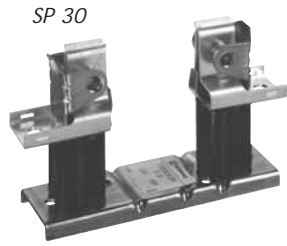

SP - SE - SF FUSEHOLDERS FOR "E" BLADE-TYPE FUSES

- MOUNTING IN ONE-POLE FUSEHOLDER SIMPLIFIES REPLACEMENT OF FUSES FOR INSTALLATIONS CONNECTED WITH CABLES AND BARS
- FOR "E" BLADE-TYPE FUSES
 - ELASTIC TIGHTENING FOR SIZES 0 TO 2
 - BOLTED TIGHTENING FOR SIZE 3

Main Characteristics

Designation	Catalog Number	Insulation voltage (V) Ui (AC 50/60 Hz & DC)	Current (A)	Maximum power* (W)	Dielectric withstand test (kV)	
					RMS voltage 1 mn 50/60 Hz	Impulse voltage 1.2/50µs
SP 30		1 250	550	31	13	20
SP 70		1 500	630	31	13	20
SP 43 120		2 500	200		13	20
SE 31		1 250	800	59	13	20
SE 32		1 250	1 800	95	13	20
SE 71		1 500	1 000	59	13	20
SE 72		1 500	1 250	95	13	20
SE 43-91		2 000	350		13	20
SE 43-92		2 000	500		13	20
SE 43 121		2 500	315		13	20
SE 43 122		2 500	500		13	20
SF 50-33		3 200	2 500	110	24	20
SF 50-73		3 200	1 800	110	24	20
SF 50-93		3 200	1 800		24	20
SF 50-123		3 200	1 800		24	20

* Maximum fuse operating current: see fuses data sheet.

Dimensions

Drawing #1 "SP" elastic tightening

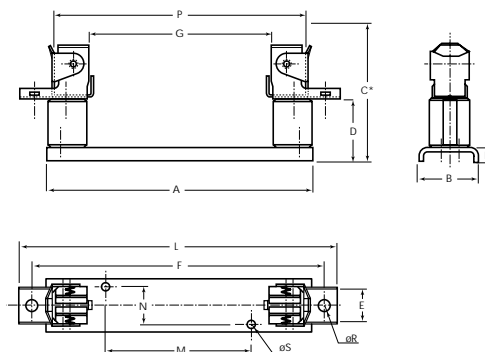



Semiconductor Fuses

AC+DC Square-boby Fuse Bases

Bases for other Blade Fuses - Size 30 to 123: SE, SP, SF

Drawing #2 "SE" elastic tightening

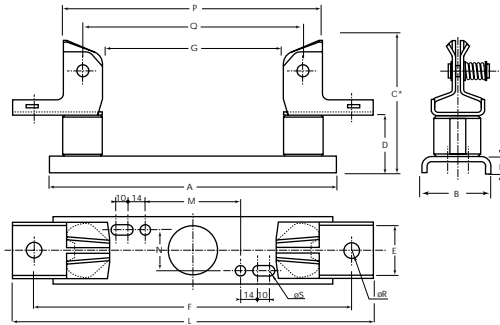

Drawing #3 "SF" bolted tightening

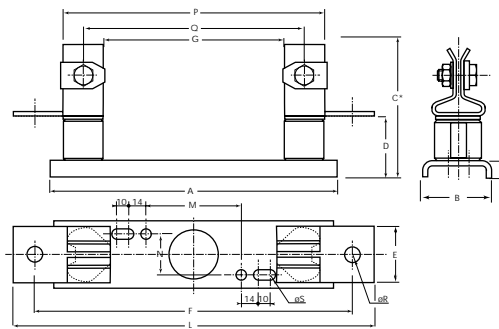

NB: For SF 50-33 types fixing dimension 14 becomes 12.5

Designation	Cat. Number	Drawing #	A	B	C*	D	E	F	G	H	L	M	N	P	Q	Ø R	Ø S
SP 30		1	138	42	109	46	26	134.5	54.5	8.5	155	52	28	98.5		8.5	5.5
SP 70		1	148	42	110.5	47.5	26	168	88	10	188	60	28	138		8.5	5.5
SP 43 120		1	194.5	42	125	54.5	26	214.5	134.5	10	234.5	106.5	28	184		8.5	5.5
SE 31		2	148	42	116	46.5	32	158.5	61.5	8.5	190.5	60	28	111.5	86.6	10.5	5.5
SE 32		2	150	54	126	49	42	180	56	10	216	45	35	126	91	12.5	8.5
SE 71		2	148	42	116	46.5	32	182	85	8.5	214	60	28	135	110	10.5	5.5
SE 72		2	150	54	126	49	42	204	80	10	240	45	35	150	115	12.5	8.5
SE 43-91		2	174	42	123	48	32	209	111	10	241	86	28	161	136	10.5	5.5
SE 43-92		2	176	54	133	50	42	230	106	15	266	23	35	176	141	12.5	8.5
SE 43 121		2	204.5	42	130	54	32	238.5	141.5	10	270.5	116.5	28	191.5	166.5	10.5	5.5
SE 43 122		2	230.5	54	140	60	42	260.5	136.5	15	296.5	77.5	35	206.5	171.5	12.5	8.5
SF 50-33		3	150	60	171	65	40	186	56	15	226	NBfig.3	35	126	91	18	8.5
SF50-73		3	174	60	171	65	40	210	80	15	250	21	35	150	115	18	8.5
SF 50-93		3	200	60	176	70	40	236	106	15	276	47	35	176	141	18	8.5
SF 50-123		3	230.5	60	176	70	40	266.5	136.5	15	306.5	77.5	35	206.5	171.5	18	8.5

* Dimension with fuse.

- Electrical connection of fuseholder and wires by screws made in plated steel 8-8 class (not supplied).

Maximum recommended tightening torque:

- M8 : 22 $\begin{smallmatrix} +0 \\ -8 \end{smallmatrix}$ Nm
- M12 : 76 $\begin{smallmatrix} +0 \\ -8 \end{smallmatrix}$ Nm
- M16 : 100 $\begin{smallmatrix} +0 \\ -10 \end{smallmatrix}$ Nm

- Fixing of base with screws:

- M5 (for sizes 0 and 1) : 7 ± 1,5 Nm
- M8 (for sizes 2 and 3) : 22 $\begin{smallmatrix} +0 \\ -8 \end{smallmatrix}$ Nm



Semiconductor Fuses AC+DC Square-boby Fuse Bases Bases for other Blade Fuses - Size 30 to 123: SE, SP, SF

SP - SE - SF FUSEHOLDERS FOR "E" BLADE-TYPE FUSES

References

Designation	Ref. Number	Catalog Number	Weight (g)	Packaging
SP 30	T 096939	SP30	370	1
SP 70	F 096099	SP70	400	1
SP 43 120	W 226247	SP43-120	500	1
SE 31	J 098701	SE31	435	1
SE 32	K 098702	SE32	900	1
SE 71	V 098711	SE71	470	1
SE 72	W 098712	SE72	940	1
SE 43-91	X 226179	SE43-91	955	1
SE 43-92	Y 226180	SE43-92	955	1
SE 43 121	T 226245	SE43-121	540	1
SE 43 122	V 226246	SE43-122	1 026	1
SF 50-33	B 209186	SF50-33	1 550	1
SF 50-73	C 209187	SF50-73	1 590	1
SF 50-93	X 209090	SF50-93	1 625	1
SF 50-123	Y 209091	SF50-123	1 720	1

Distance "X" between Pole axes (without partition)

	Designation	Operating voltage U						
		400 V	550 V	690 V	750 V	1 000 V	1 250 V	1 500 V
Without partition	SP 30 SP 70 SP 43 120	45	50	54	55	60	65	68
	SE 31 SE 71 SE 43-91 SE 43-121	56	61	65	66	71	76	79
	SE 32 SE 72 SE 43-92 SE 43-122	65	70	74	75	80	85	88
	SF 50-33 SF 50-73 SF 50-93 SF 50-123	79,5	84,5	88,5	89,5	94,5	99,5	102,5

