

# Surge-Trap<sup>®</sup> PV

**Solar Power**

**Surge Protection  
Solutions**

[www.ferrazshawmut.us](http://www.ferrazshawmut.us)

Transportation



Power conversion



Power generation  
& distribution



Industrial  
controls



Power  
quality



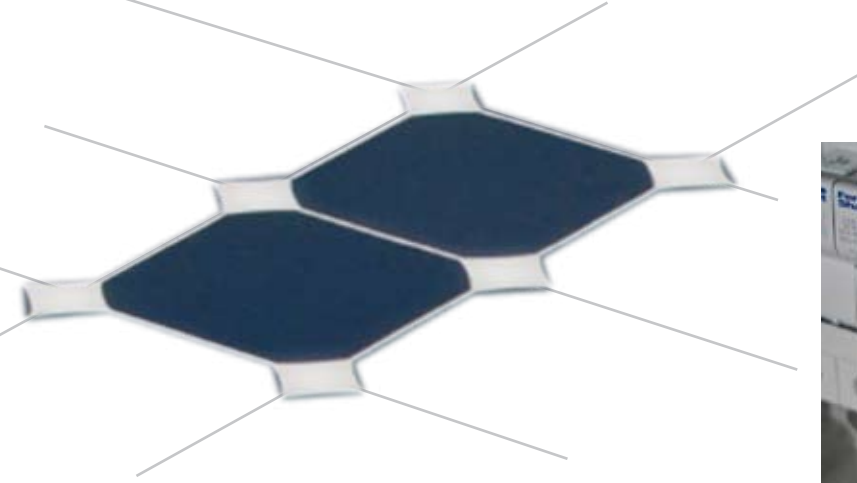

# Advanced Protection for solar cell systems

Solar Photovoltaic (PV) systems require a sizable investment and must be operational for several years before a significant return on investment is realized. To ensure your PV systems reach maturity, you must protect your investment from severe lightning and unstable utility power.

Ferraz Shawmut's Surge-Trap® PV surge protective device is the right protection for your investment. The Surge-Trap PV utilizes Ferraz Shawmut's patented TPMOV design, which eliminates the need for additional overcurrent protection due to its ability to withstand high short circuits. Designed to be mounted on a 35mm DIN-rail, the Surge-Trap PV offers individual mode visual indication and optional remote indication, giving you status to critical control circuits at a glance.



→ The Surge-Trap PV Surge Protective Device provides advanced protection for photovoltaic and solar cell systems.



## Surge-Trap Pluggable Features

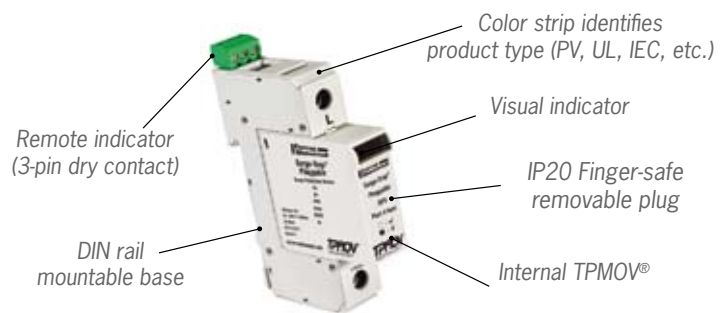

## Surge-Trap Modular Features

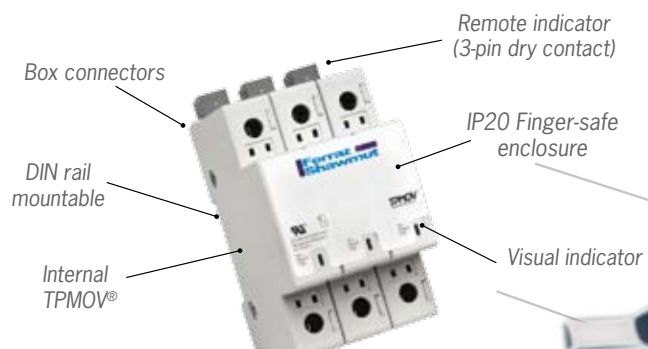



# The unique benefits

# of the Surge-Trap® PV

The Surge-Trap is a fail-safe surge suppressor that is easy to install or retrofit. Direct connection is available with the DIN-rail mount option. The Surge-Trap has a small foot print, visual indicator and an IP20 finger-safe design. Optional remote indicators are available when status to critical control circuits are needed and doesn't require any fuses or overvoltage protection.

## Surge-Trap PV Pluggable and Modular Ordering Information

No	Surge-Trap Pluggable System (Includes Base & Plugs)	Nominal Voltage (Vac)	MCOV (Uc) L-PE(N)	No of Poles	System Type	Nominal Discharge Current * (In, kA)	Max. Discharge Current (Imax, 8/20, kA)	Short Circuit Current Rating (SCCR), (kA)	Voltage Protection Level (Up @ In), (kV)	Replacement Plug Part No
1	STP600PVM	600	675 VDC	2	DC	10	50	100	< 2.0	SP510E
2	STP1000PVM	1000	1120 VDC	3	DC	10	50	100	< 4.0	SP420E
No	Surge-Trap Modular System	Nominal Voltage (Vac)	MCOV (Uc) L-PE(N)	No of Poles	System Type	Nominal Discharge Current * (In, kA)	Max. Discharge Current (Imax, 8/20, kA)	Short Circuit Current Rating (SCCR), (kA)	Voltage Protection Level (Up @ In), (kV)	Replacement Plug Part No
1	ST600PVM	600	670 VDC	2	DC	20	50	100	< 2.0	NA
2	ST1000PVM	1000	1120 VDC	3	DC	20	50	100	< 4.0	NA

\*Values based upon SPD Type 2 testing

### Surge-Trap Pluggable Dimensional Diagrams

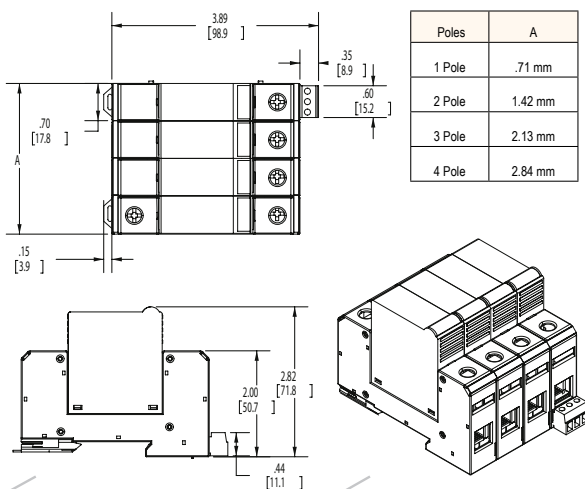

### Surge-Trap Modular Dimensional Diagrams

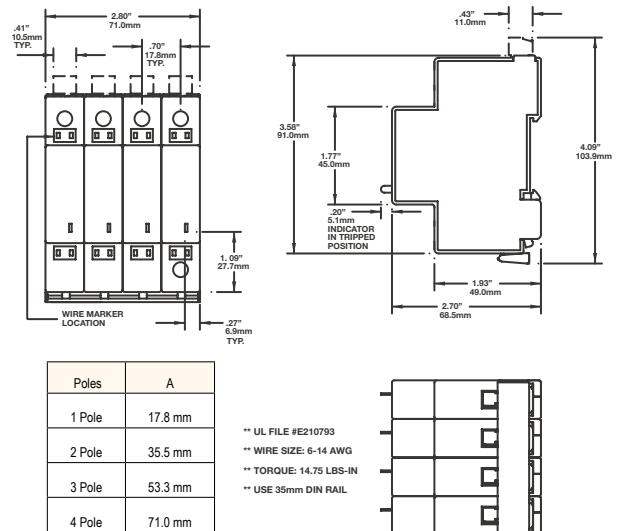

### Surge-Trap Microswitch Diagram

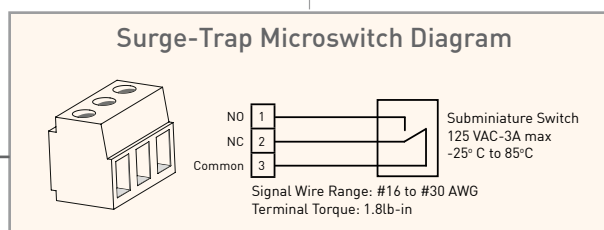

One microswitch per system

One microswitch per pole



[www.ferrazshawmut.us](http://www.ferrazshawmut.us)

**Ferraz**  
**Shawmut**

中國總代理 Distributor:

萬高寶有限公司 Majestic Global Limited

香港沙田安平街八號偉達中心1207-8室

Tel: 852 23078933 Fax 852 23078950 Email: [info@mgl.com.hk](mailto:info@mgl.com.hk)

Website: [www.mgl.com.hk](http://www.mgl.com.hk)