



**AC SPEED CONTROL EQUIPMENT**

**VAT2000**

3ph 200V-230V System 0.4 to 45kW  
3ph 380V-460V System 0.4 to 370kW

**INSTRUCTION MANUAL**

----- **NOTICE** -----

1. Read this manual thoroughly before using the VAT2000, and store in a safe place for reference.
2. Make sure that this manual is delivered to the final user.
3. The contents of this manual can be changed without notice

---

GE POWER CONTROLS

# Contents

<b>Preface</b> .....	<b>iii</b>
<b>PRECAUTIONS FOR SAFETY</b> .....	<b>iv</b>
<b>&lt;Names of each part&gt;</b> .....	<b>viii</b>
<b>Chapter 1 Delivery Inspection and Storage</b> .....	<b>1-1</b>
1-1 Delivery inspection and storage .....	1-1
1-2 Details of rating nameplate and catalogue numbers .....	1-1
<b>Chapter 2 Installation and Wiring</b> .....	<b>2-1</b>
2-1 Installation environment .....	2-1
2-2 Installation.....	2-2
2-3 Precautions for power supply and motor wiring .....	2-3
2-4 Precautions for wiring to the control signal .....	2-8
<b>Chapter 3 Test Operation and Adjustment</b> .....	<b>3-1</b>
3-1 Control selection .....	3-2
3-2 Selection of operation mode .....	3-2
3-3 Flow of test operation .....	3-3
3-4 Preparation for operation .....	3-4
3-5 Settings of data before operation .....	3-4
3-6 Automatic tuning .....	3-4
3-7 Test operation with operation panel .....	3-15
<b>Chapter 4 Operation Panel</b> .....	<b>4-1</b>
4-1 Details of operation panel .....	4-1
4-2 Modes and parameters .....	4-3
4-3 Changing modes .....	4-12
4-4 Reading parameters in monitor mode .....	4-13
4-5 Reading and adjusting block-A, B & C parameters .....	4-14
4-6 Reading the changed parameters (Non-default value parameter list) .....	4-16
4-7 Customising block-B, C parameter .....	4-18
4-8 Reading fault history.....	4-20
<b>Chapter 5 Control Input / Output</b> .....	<b>5-1</b>
5-1 Input / Output Terminal Function .....	5-1
5-2 Control Input/ Output Circuit .....	5-2
5-3 Programmable sequence input function (PSI) .....	5-3
5-4 Programmable sequence output function (PSO) .....	5-7
5-5 Sequence input logic .....	5-8
5-6 Changing of terminal functions .....	5-9
5-7 Programmable analog input function (PAI) .....	5-11
5-8 Programmable analog output function (PAO) .....	5-13
5-9 Selecting the setting data .....	5-14

<b>Chapter 6 Control Functions and Parameter Settings .....</b>	<b>6-1</b>
6-1 Monitor parameters .....	6-1
6-2 Block-A parameters .....	6-5
6-3 Block-B parameters .....	6-7
6-4 Block-C parameters .....	6-20
6-5 Block-U parameters .....	6-32
6-6 Function explanation .....	6-33
6-7 Application to square low variable torque load .....	6-73
6-8 Adjusting the vector control speed control related parameters .....	6-76
<b>Chapter 7 Options .....</b>	<b>7-1</b>
7-1 Outline of options .....	7-1
7-2 VAT2000's Main options .....	7-5
7-3 Built-in PCB option .....	7-6
7-4 Dynamic braking (DBR).....	7-7
7-5 Electromagnetic compliance, EMC .....	7-11
7-6 Reactors and Surge Absorber Filters .....	7-13
<b>Chapter 8 Maintenance and Inspection .....</b>	<b>8-1</b>
8-1 Inspection items .....	8-1
8-2 Measuring devices .....	8-2
8-3 Protective functions .....	8-3
8-4 Troubleshooting with fault display .....	8-4
8-5 Troubleshooting with no fault display .....	8-8
<b>Appendix 1 Type Description System.....</b>	<b>A-1</b>
<b>2 Outline Dimension Drawings .....</b>	<b>A-9</b>
<b>3 Fault Codes .....</b>	<b>A-10</b>
<b>4 7-segment LED Display .....</b>	<b>A-12</b>

## Preface

Please read this manual thoroughly before use, and keep the manual at hand for later reference. Also make sure that this manual is delivered to the final users.

### **WARNING**

#### **ALWAYS READ THIS MANUAL THOROUGHLY BEFORE USING THE VAT2000**

THIS INVERTER CONTAINS HIGH VOLTAGE CIRCUITS THAT MAY BE FATAL TO HUMANS. USE EXTREME CAUTION DURING INSTALLATION. MAINTENANCE MUST BE PERFORMED BY QUALIFIED TECHNICIANS, AND ALL POWER SOURCES MUST BE DISCONNECTED BEFORE ANY MAINTENANCE. SUFFICIENT NOTICE MUST BE GIVEN TO THE GENERAL OPERATORS AND WORKERS BEFORE STARTING.

- **ELECTRIC SHOCK MAY OCCUR IF THE FOLLOWING POINTS ARE NOT OBSERVED.**
  - DO NOT OPEN THE OUTER-COVER (FRONT COVER) WHILE THE POWER IS ON.
  - A CHARGE STILL REMAINS IN THE INVERTER WHILE THE INDICATOR IS LIT EVEN IF THE POWER HAS BEEN TURNED OFF. DO NOT OPEN THE OUTER-COVER (FRONT COVER) IN THIS CASE. WAIT AT LEAST 10 MINUTES AFTER THE INDICATOR GOES OUT.
  - DO NOT CONTACT THE ELECTRICAL CIRCUIT WHILE THE CHARGE LAMP ON THE PCB IS LIT. PERFORM SERVICING, ETC., AFTER WAITING AT LEAST 10 MINUTES AFTER THE LAMP GOES OUT.
  - ALWAYS GROUND THE INVERTER CASE. THE GROUNDING METHOD MUST COMPLY WITH THE LAWS OF THE COUNTRY WHERE THE INVERTER IS BEING INSTALLED.
  
- **THE INVERTER MAY BE DESTROYED IF THE FOLLOWING POINTS ARE NOT OBSERVED.**
  - OBSERVE THE INVERTER SPECIFICATIONS.
  - CONNECT ADEQUATE CABLES TO THE INPUT/OUTPUT TERMINALS.
  - ALWAYS KEEP THE INVERTER INTAKE/OUTTAKE PORTS CLEAN, AND PROVIDE ENOUGH VENTILATION.
  - ALWAYS OBSERVE THE CAUTIONS LISTED IN THIS INSTRUCTION MANUAL.
  
- THERE MAY BE SOURCES OF NOISE AROUND THIS INVERTER AND MOTOR DRIVEN BY THIS INVERTER. CONSIDER THE POWER SUPPLY SYSTEM, INSTALLATION PLACE AND WIRING METHOD BEFORE INSTALLATION. INSTALL THIS INVERTER AWAY FROM DEVICES THAT HANDLE MINUTE SIGNALS, SUCH AS MEDICAL EQUIPMENT IN PARTICULAR. ALSO SEPARATE THE DEVICES ELECTRICALLY, AND TAKE SUFFICIENT NOISE MEASURES.
  
- TAKE SUFFICIENT SAFETY MEASURES WHEN USING THIS INVERTER FOR PASSENGER TRANSPORTATION, SUCH AS IN LIFTS (ELEVATORS).

# Precautions For Safety

Items to be observed to prevent physical damage and to ensure safe use of this product are noted on the product and in this instruction manual.

- Please read this instruction manual and enclosed documents before starting operation to ensure correct usage. Thoroughly understand the device, safety information and precautions before starting operation. After reading, always store this manual where it can be accessed easily.
- The safety precautions are ranked as “**DANGER**” and “**CAUTION**” In this instruction manual.

## **DANGER**

: When a dangerous situation may occur if handling is mistaken leading to fatal or major injuries.

## **CAUTION**

: When a dangerous situation may occur if handling is mistaken leading to medium or minor injuries, or physical damage.

Note that some items described as **CAUTION** may lead to major results depending on the situation. In any case, important information that must be observed is described.

- This instruction manual is written on the premise that the user has an understanding of the inverter. Installation, operation, maintenance and inspection of this product must be done by a qualified person. Even qualified persons must undergo periodic training.

### **Qualified refers to satisfying the following conditions.**

- The person has thoroughly read and understood this instruction manual
- The person is well versed in the installation, operation maintenance and inspection of this product, and understands the possible dangers,
- The person is informed on matters related to starting, stopping, installation, locks and tag displays, and has been trained in the operation and remedies.
- The person has been trained on the maintenance, inspection and repairs of this product.
- The person has been trained on protective tools used to ensure safety.

## 1. Transportation and installation

### **CAUTION**

- Always transport the product with an appropriate amount according to the products weight  
Failure to observe this could lead to injuries.
- Install the inverter and brake resistor on non-combustible material such as metal.  
Failure to observe this could lead to fires.
- Do not place the product near inflammable items.  
Failure to observe this could lead to fires.
- Do not hold the from cover while transporting the product.  
Failure to observe this could lead to injuries from dropping.
- Do not led conductive materials such as screws or metal pieces and inflammable material such as oil enter the product.  
Failure to observe this could lead to fires.
- Install the product in a place that can withstand the weight of the product, and follow the instruction manual  
Failure to do so could lead to injuries from dropping.
- Do not install and operate an inverter that is damaged or that is missing parts.  
Failure to observe this could lead to injuries.
- Always observe the conditions described in the instruction manual for the installation environment.  
Failure observe this could lead to faults.

## 2. Wiring

### DANGER

- Always turn the device's input power OFF before starting wiring.  
Failure to do so could lead to electrical shocks or fires.
- Carry out grounding that complies with the standards of the country where the inverter is being installed. Failure to do so could lead to electrical shocks or fires.
- Wiring must always be done by a qualified electrician.  
Failure to observe this could lead to electrical shocks or fires.
- Always install the device before starting wiring.  
Failure to do so could lead to electrical shocks or injuries.
- Prepare a breaker such as an MCCB that matches the capacity for the inverter's power supply side  
Failure to do so could lead to fires.

### CAUTION

- Do not connect an AC power supply to the output terminals (U, V, W).  
Failure to observe this could lead to electrical shocks or fires.
- Confirm that the product's rated voltage and frequency match the power supply voltage and frequency.  
Failure to do so could lead to injuries or fires.
- Install an overheating protection device on the dynamic electrical-discharge braking resistor, and shut off the power with an error signal.  
Failure to do so could lead to fires in the event of abnormal overheating.
- Do not directly connect a resistor to the DC terminals (between L+1, L+2, and L-).  
Failure to observe this could lead to fires.
- Tighten the terminals screws with the designated tightening torque.  
Failure to do so could lead to fires.
- Correct connect the output side (U, V, W).  
Failure to do so could cause the motor to rotate in reverse and the machine to be damaged

## 3. Operation

### DANGER

- Always install the from cover before turning the input power ON. Never remove the cover while the power is ON. There are sections in the from PCB that are charged with high voltages.  
Failure to observe this could lead to electrical shocks.
- Never touch the switches with wet hands.  
Failure to observe this could lead to electrical shocks.
- Never touch the inverter's terminals while the inverter power is ON even if the operation is stopped  
Failure to observe this could lead to electrical shocks
- Selection of the retry function could lead to unexpected restarting when an alarm occurs. The machine may start suddenly if the power is turned ON when the automatic start function is selected Do not go near the machine.  
Failure to do so could lead to injuries.  
(Design the machine so that physical safety can be ensured even if the machine restarts.)
- The machine may not stop when a stop command is issued if the deceleration stop function is selected. Prepare a separate emergency stop switch.  
Failure to do so could lead to injuries.
- Resetting of an alarm while the run signal is input could lead to unexpected restarting. Always confirm that the run signal is OFF before resetting the alarm.  
Failure to do so could lead to injuries.

Continue from previous page

**CAUTION**

- The heat sink and dynamic braking resistor are heated to high temperatures, so never touch them. Failure to observe this could lead to burns.
- Do not block the inverter's ventilation holes. Failure to observe this could lead to fires.
- The inverter operation can easily be set from low speeds to high speeds, so confirm that the operation is within the tolerable range for the motor or machine before making settings. Failure to do so could lead to injuries.
- Prepare holding brakes when necessary. Holding is not possible with the inverter's brake functions. Failure to do so could lead to injuries.
- Confirm the operation of the motor as a single unit before operating the machine. Failure to do so could lead to injuries or machine damage due to unforeseen movements.
- Always prepare a safety backup device so that the machine is not placed in a hazardous situation when an error occurs in the inverter. Failure to do so could lead to injuries or machine damage.

#### 4. Maintenance, Inspection and Part Replacement

**DANGER**

- Always wait at least 20 minutes after turning the input power OFF before starting inspections. Make sure that the displays on the operation panel have gone out before removing the front cover. Remove the front cover, and confirm that the "CHARGE" LED on the unit has gone out. Also check that the voltage between terminals L+1 or L+2 and L- is 15V or less before starting the inspections. (Check with the "CHARGE" LED if the unit is not provided with the L- terminal.) Failure to observe this could lead to electrical shocks.
- Maintenance, inspections and part replacement must be done by a designated person. (Remove all metal accessories such as watches, bracelets, etc., before starting the work.) (Always use an insulation measure tool.) Failure to observe this could lead to electrical shocks and injuries.
- Always turn the power OFF before inspecting the motor or machine . A potential is applied on the motor terminal even when the motor is stopped. Failure to do so could lead to electrical shocks and injuries.
- Do not use parts other than those designated for the replacement parts. Failure to observe this could lead to fires.

**CAUTION**

- Vacuum the inverter with a vacuum cleaner to clean it. Do not use organic solvents. Failure to observe this could lead to fires or damage.

#### 5. Others

**DANGER**

- Never modify product. Failure to observe this could lead to electrical shocks or injuries.

**CAUTION**

- Dispose of this product as industrial waste.

## <Names of each part>

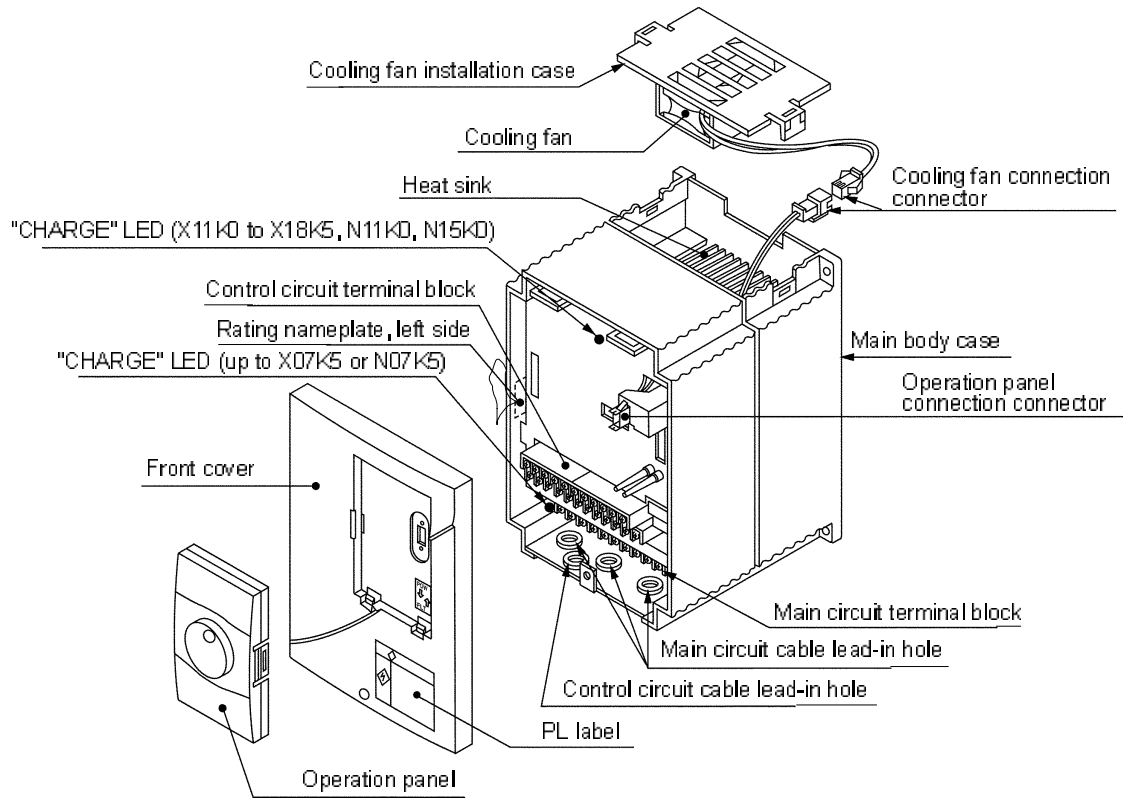

### For U2KN15K0S, U2KX18K5S and smaller

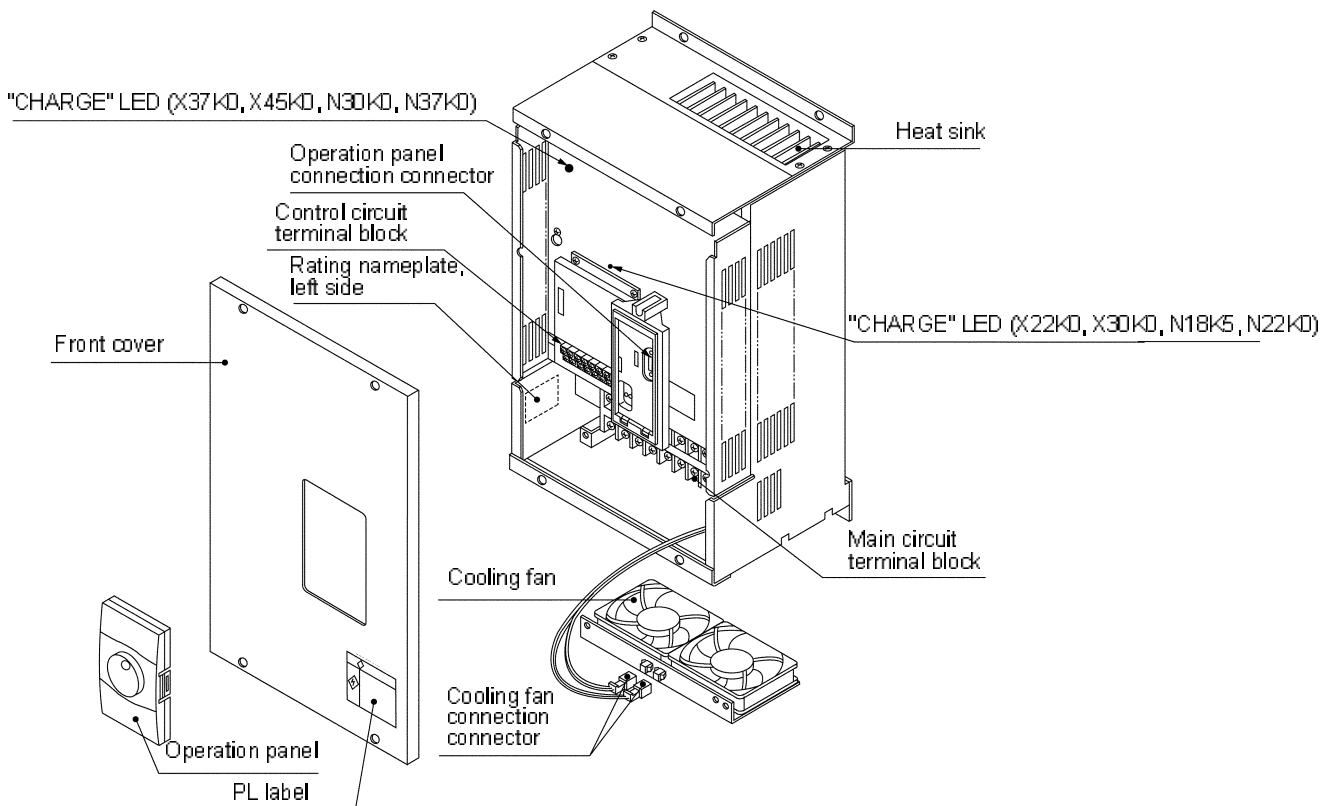

### For U2KN18K5S to U2KN37K0S and U2KX22K0S or larger

## Chapter 1 Delivery Inspection and Storage

### 1-1 Delivery Inspection and Storage

- 1) Remove the inverter from the packaging, and check the details on the rating nameplate to confirm that the inverter is as ordered. The rating nameplate is on the left side of the unit.
- 2) Confirm that the product has not been damaged.
- 3) If the inverter is not to be used for a while after purchasing, store it in a place with no humidity or vibration in the packaged state.
- 4) Always inspect the inverter before using after storing for a long period. (Refer to 8-1.)

### 1-2 Details of Rating Nameplate and catalogue numbers

- 1) The following details are listed on the rating nameplate.

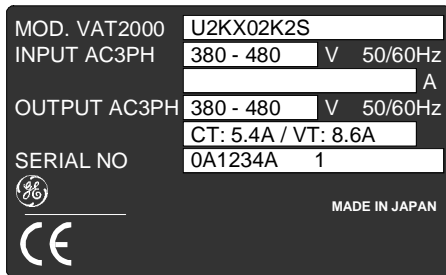

#### CAUTION

**CT:** Rating for standard applications (Constant Torque)

**VT:** Rating only for Fans and Pumps (Variable Torque)

**CT/VT settings are described on chapter 6-6**

- 2) Using the above type as an example, the type is displayed as follows:

**U2K X02K2 S**

#### Source voltage and capacity

NxxKx: 200V Series

XxxKx: 400V Series

Refer to Appendix for more details

#### Indicates main circuit options

S: Standard (AC Supply)

D: DC Supply

Refer to chapter 7 (Main Options)

The VAT2000 can be performed by the user with various optional interface plug-in cards. Refer to Chapter 7 (PCB Options)

## Chapter 2 Installation and Wiring

### CAUTION

- Always transport the product with an appropriate amount according to the products weight.  
Failure to observe this could lead to injuries.
- Install the inverter, dynamic braking unit and resistor, and other peripheral devices on non-combustible material such as metal.  
Failure to observe this could lead to fires.
- Do not place the product near inflammable items.  
Failure to observe this could lead to fires.
- Do not hold the front cover while transporting the product.  
Failure to observe this could lead to injuries from dropping.
- Do not let conductive materials such as screws or metal pieces and inflammable materials such as oil enter the product.  
Failure to observe this could lead to fires.
- Install the product in a place that can withstand the weight of the product, and follow the instruction manual.  
Failure to do so could lead to injuries from dropping.
- Do not install and operate an inverter that is damaged or that is missing parts.  
Failure to observe this could lead to injuries.
- Always observe the conditions described in the instruction manual for the installation environment.  
Failure to observe this could lead to faults.

### 2-1 Installation Environment

Observe the following points when installing the inverter.

- 1) Install the inverter vertically so that the wire lead-in holes face downward.
- 2) Make sure that the ambient temperature is  $-10^{\circ}\text{C}$  to  $50^{\circ}\text{C}$ .
- 3) Avoid installation in the following environment.
  - Places subject to direct sunlight
  - Places with oil mist, dust or cotton lint, or subject to salty winds
  - Places with corrosive gas, explosive gas or high humidity levels
  - Places near vibration sources such as dollies or press machines
  - Places made of flammable materials such as wood, or places that are not heat resistant
- 4) Ensure ventilation space around the inverter.

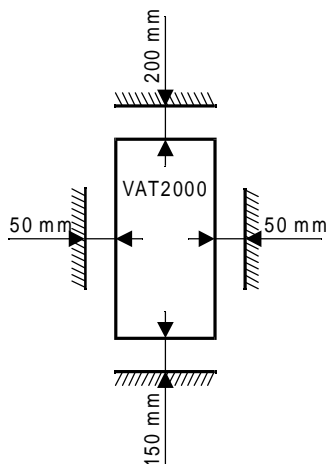

For N15K0, X18K5 and smaller

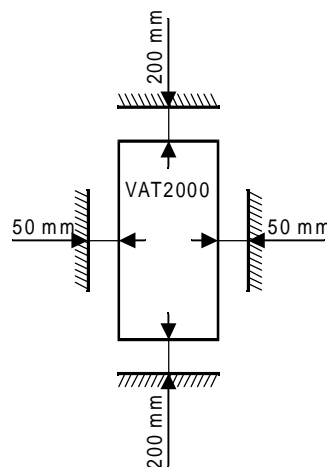

For N18K5, X22K0 and larger

### 2-2 Installation

Installation and wiring for the N15K0, H18K5 and smaller drives, and wiring for the N18K5 and X22K0 and larger drives are carried out with the front cover removed.

Before removing the front cover, always remove the operation panel from the unit. If the front cover is removed without removing the operation panel, the unit could drop off the operation panel and be damaged. To remove the operation panel, press in the left and right latches inward and pull off the panel as shown on the right.

When the installation and wiring work are completed, install the front cover, and then install the operation panel. At that time, make sure that the latches on the left and right of the operation panel are securely caught.

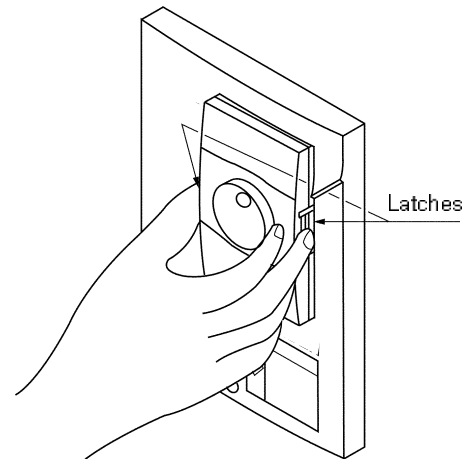

#### (1) N15K0, X18K5 and smaller (Fig. 2.2)

Fix the VAT2000 on the four corners, note that the lower two mounting holes are notched. Remove the front cover, and wire to the main circuit and control terminal block.

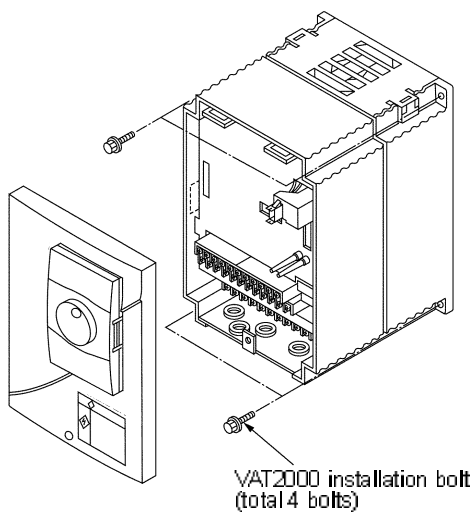

Fig 2.2

#### (2) N18K5, X22K0 and larger (Fig. 2.3)

Fix the VAT2000 on the four corners, note that the lower two mounting holes are notched. These frames weigh more than 25kg, so installation by two workers is recommended.

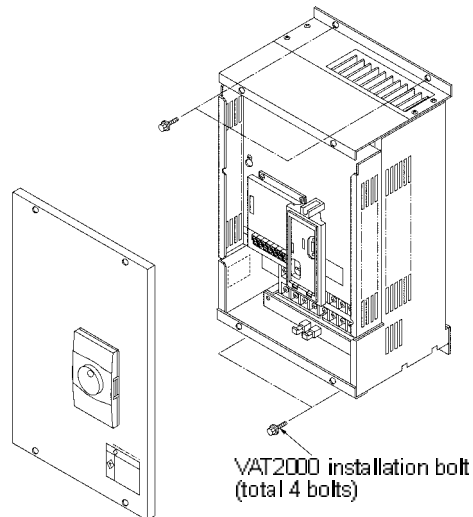

Fig 2.3

### 2-3 Precautions for Power Supply and Motor Wiring

#### DANGER

- Always turn the device's input power OFF before starting wiring.  
Failure to do so could lead to electrical shocks or fires.
- Carry out grounding that complies with the standards of the country where the inverter is being installed.  
Failure to do so could lead to electrical shocks or fires.
- Wiring must always be done by a qualified electrician.  
Failure to observe this could lead to electrical shocks or fires.
- Always install the device before starting wiring.  
Failure to do so could lead to electrical shocks or injuries.
- Prepare a breaker such as an MCCB or fuses that matches the capacity for the inverter's power supply side.  
Failure to do so could lead to fires.

#### CAUTION

- Do not connect an AC power supply to the output terminals (U, V, W).  
Failure to observe this could lead to injuries or fires.
- Confirm that the product's rated voltage and frequency match the power supply voltage and frequency.  
Failure to do so could lead to injuries or fires.
- Install an overheating protection device on the dynamic braking resistor, and shut off the power with an error signal.  
Failure to do so could lead to fires in the event of abnormal overheating.
- Do not directly connect a resistor to the DC terminals (between L+1, L+2 and L-).  
Failure to observe this could lead to fires.
- Tighten the terminal screws with the designated tightening torque.  
Failure to do so could lead to fires.
- Correct connect the output side (U, V, W).  
Failure to do so could cause the motor to rotate in reverse and the machine to be damaged.

Refer to Fig. 2-4 and wire the main circuits for the power supply and motor, etc.  
Always observe the following precautions for wiring.

#### CAUTION

There is a risk of electrical shocks.  
The VAT2000 has a built-in electrolytic capacitor, so a charge will remain even when the inverter power is turned OFF. Always observe the following times before carrying out wiring work.

- Wait at least 20 minutes after turning the power OFF before starting work. Make sure that the displays on the operation panel have gone out before removing the cover.
- After removing the cover, confirm that the "CHARGE" LED at the following position has gone out. Also check that the voltage between terminals L+1 or L+2 and L- is 15V or less before starting the inspections. (Check with the "CHARGE" LED if the unit is not provided with the L- terminal.)

## 2. Installation and Wiring

### Main circuit wiring

a) U2KN07K5S, U2KX07K5S and smaller units. For DC Drives (main option "D"), check Chapter 7-2.

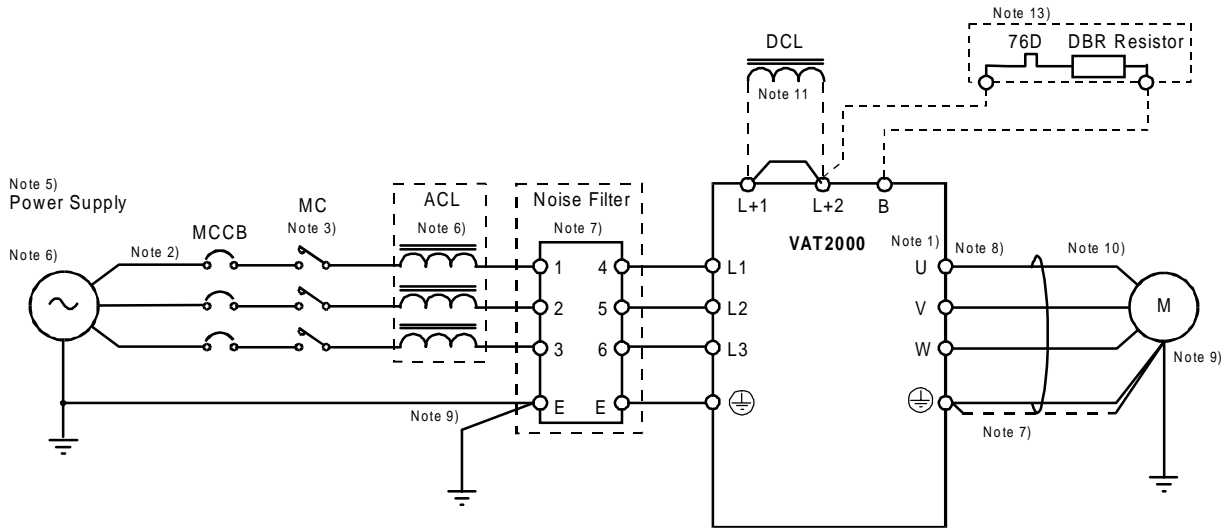

b) From U2KN11K0S, and U2KX11K0S to U2KX37K0S. For DC Drives (main option "D"), check Chapter 7-2.

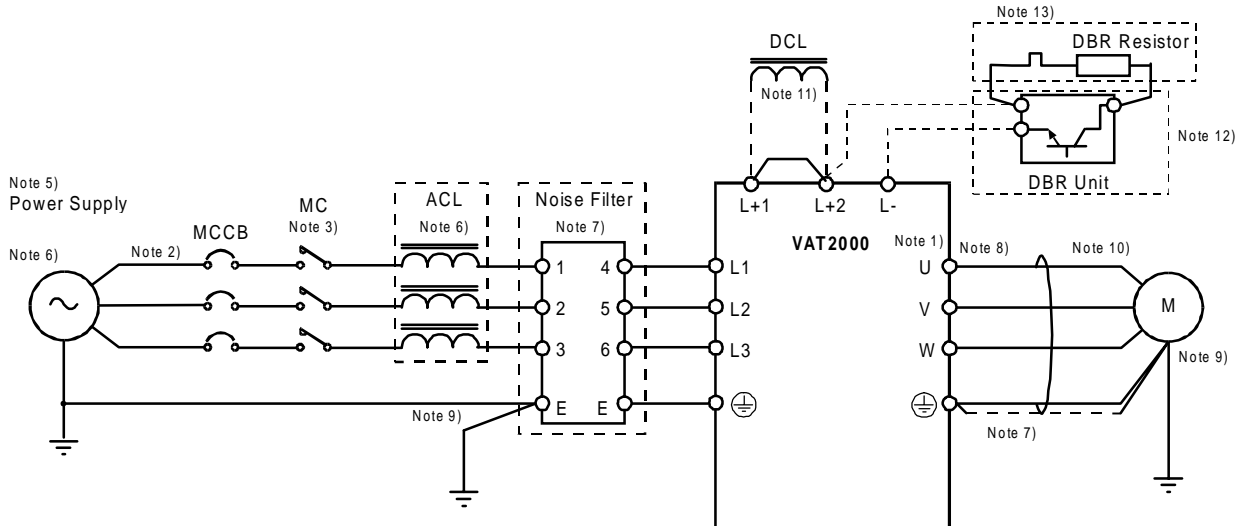

c) U2KX45K5S and larger units. For DC Drives (main option "D"), check Chapter 7-2.

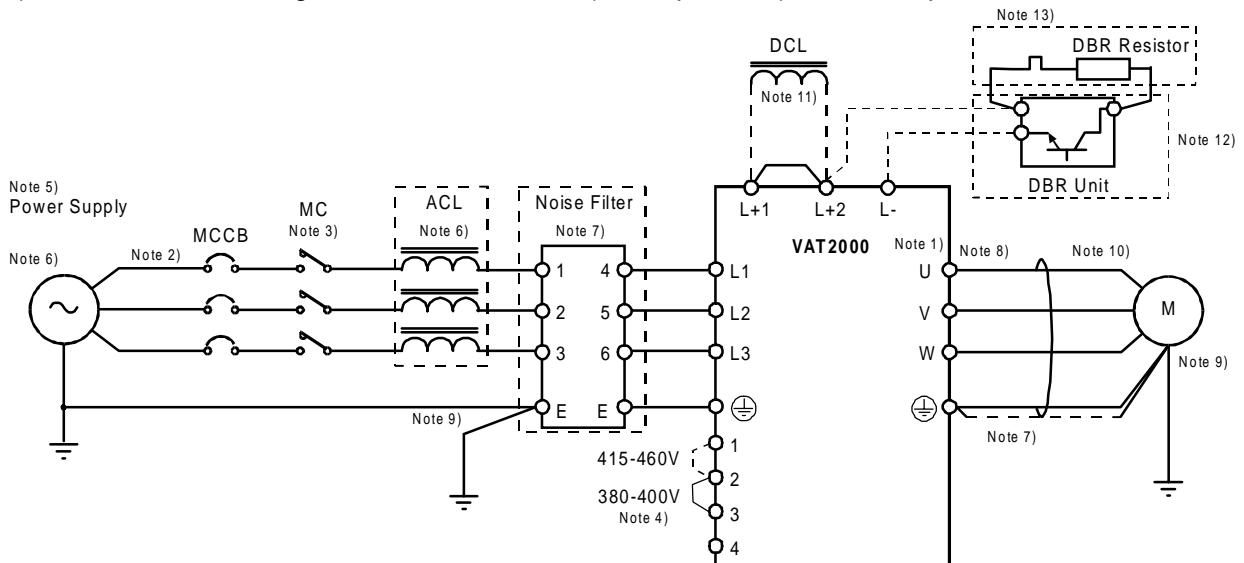

**Fig. 2.4 Example of main circuit wiring**

## 2. Installation and Wiring

**Note 1) Inverter Input / Output terminals**

The inverter input terminals are L1, L2 and L3. The output terminals to the motor are U, V and W. Do not connect the power supply to the U, V, W terminals. incorrect wiring will cause to inverter damage or fires.

**Note 2) Wire size**

For the main circuit wiring shown in Fig. 2-4, use wires recommended in Table 2-1, including wire size range, ring terminal and tightening torque. The applicable wire given in Table 2-1 is for using in constant torque ratings; for variable torque, select the wire given for one higher rating, shifting one column to the right.

**Example:** For the X45K0 drive variable torque, use the column of N30K0 drive (for the N37K0 variable torque, use the N37K0 column however)

**Table 2-1 Applicable wire sizes and terminals**

**a) Power supply and motor wiring (L1, L2, L3, U, V, W, L+1, L+2, L-)**

Inverter type VAT2000	200V Series	~02K2	04K0	05K5	07K5		11K0	15K0		18K5 22K0	30K0	37K0
	400V Series	~04K0	05K5 07K5	11K0	15K0	18K5	22K0		30K0	37K0 45K0		
<b>Applicable wire</b>	mm <sup>2</sup>	2.5	4	6.3	8	16		25		35	60	100
<b>Max. ring terminal (mm)</b>		<b>d1</b>	8.5	9.5	12		16.5		22		28.5	
		<b>d2</b>	4.3		5.3		6.4		8.4		10.5	
<b>Terminal screw</b>		M4		M5		M6		M8		M10		
<b>Tightening torque [N•m]</b>		1.2		2		4.5		9		18		

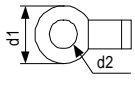
Inverter type VAT2000	400V Series	55K0 75K0	90K0 110K	123K 160K	200K	250K 315K	
<b>Applicable wire</b>	mm <sup>2</sup>	100	150	100x2p	150x2p	200x2p	
<b>Max. ring terminal (mm)</b>		<b>d1</b>	28.5	36	28.5	36	44
		<b>d2</b>	10.5			17	
<b>Terminal screw</b>		M10			M16		
<b>Tightening torque [N•m]</b>		28.9			125		

**Note 1)** 2p refers to two parallel connections

## 2. Installation and Wiring

### b) DBR wiring (N07K5, X07K5 and smaller L+2, B) (N11K0, X11K0 and larger L+2, L-)

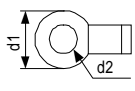
Inverter type VAT2000	200V Series	~02K2	04K0	05K5	07K5		11K0	15K0	18K5 22K0	30K0	37K0
	400V Series	~04K0	05K5 07K5	11K0	15K0	18K5		22K0	30K0	37K0 45K0	
Applicable wire	mm <sup>2</sup>	2.5					4	6.3	16		
Max. ring terminal (mm) 	d1	8.5		9.5		12		15		28.5	
	d2	4.3		5.3		6.4		8.4		10.5	
Terminal screw		M4		M5		M6		M8		M10	
Tightening torque [N•m]		1.2		2		4.5		9		18	

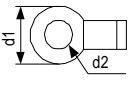
Inverter type VAT2000	400V Series	55K0 75K0	90K0 110K	123K 160K	200K	250K 315K
Applicable wire	mm <sup>2</sup>	16			25	
Max. ring terminal (mm) 	d1	16			30	
	d2	10.5			17	
Terminal screw		M10			M16	
Tightening torque [N•m]		28.9			125	

**Note 3) Circuit Breaker for wiring**

Install an MCCB or Fuse and MC on the power supply side of the inverter. Refer to Table 7.2 and select the MCCB or fuses. UL is meet using right fuse only

**Note 4) Rated voltage for auxiliary equipment supply**

For the 400 Series(X45K0 and larger), wire the link in power supply terminal (TBA) according to the rated voltage of the power supply being used.

For 380 to 400V, link across 2-3 (factory setting state)

For 415 to 460V, link across 1-2

**Note 5) Refer to the appendix 1 for the power supply voltage and frequency, and prepare a power supply suitable for the unit.**

**Note 6) Power supply capacity**

Make sure that capacity of the transformer used as the inverter's power supply is within the following range (For 4% impedance transformer)

a) Constant torque (U2KX45K0S and smaller): 500kVA or less

(U2KX55K0S and larger): Capacity is 10 times or less inverter capacity

b) Variable torque: Capacity that is 10-times or less inverter capacity

If the above values are exceeded, install an AC Reactor on the inverter's input side or a DC Reactor in the DC stage. (Refer to chapter 7-5).

## 2. Installation and Wiring

---

### Note 7) Noise measures

The inverter will generate high harmonic electromagnetic noise, so using the following noise measures is recommended. This must be followed for EMC (CE compliance)

- a) Insert a noise filter on the input side of the inverter. Refer to Table 7-2 and select the noise filter.
- b) Keep the wiring length between the noise filter and inverter to 30cm or less for the N00K4 to N22K0, X00K4 to X30K0, and 50cm or less for the U2KN30K0S, U2KX37K0S or larger.
- c) Use a shield cable for the inverter and motor wiring, and connect the screen to the inverter's ground terminal and motor grounding terminal.
- d) When both control circuit wiring and main circuit are wired in parallel, keep distance of 30cm or more, or pass each of the wiring through metal conduits. If the control circuit wiring and main circuit wiring intersect, make sure that they intersect at a right angle.

### Note 8) Inverter output

- a) Do not insert a power factor improvement capacitor on the output side of the inverter.
- b) When inserting a magnetic contactor on the output side of the inverter, prepare a sequence control circuit so that the magnetic contactor will open and close after the inverter stops.
- c) Connect only the motor to the inverter output. Do not connect through transformer etc.

### Note 9) Grounding

Always wire the inverter's ground terminal. The ground must be according to the regulations of the Country where the inverter is being used .

### Note 10) Inverter output surge voltage (For 400V Series)

The surge voltage applied on the motor side increases depending the output cable length, If this wiring between motor and drive exceeds in 30mts, connect a surge absorber exclusive for the inverter output.

### Note 11) DCL

Always short circuit across L+1 and L+2 when not using the DCL. (Factory setting state)

When connecting the optional DCL, connect it to L+1 and L+2.

Twist the wiring to the DCL, and keep the wiring length to 5m or less.

### Note 12) DB unit

When connecting the optional DB unit, follow Fig. 2-4 (2) and connect the L+2 and L- for 011L, 011H and larger.

The DB unit and inverter unit will both be damaged if the connection is incorrect.

Twist the wiring to the DBR unit, and keep the wiring length to 3m or less.

Refer to Section 7-4 for details.

### Note 13) DB protection

When using the optional DB unit, use the DB's overload detection relay or insert a thermal relay (76D) to protect the DBR resistor and inverter. Prepare a sequence control circuit to turn OFF the magnetic contactor (MC) on the input side of the inverter or trip the wiring breaker (MCCB) with trip coil using the contact of the DBR unit's overload detection relay or it's thermal relay (76D).

### Note 14) Contactor's coils

Install a surge absorber on the magnetic contactor or relay coils installed near the inverter.

## 2. Installation and Wiring

(a) U2KN00K4S - U2KN04K0S  
U2KX00K4S - U2KX04K0S

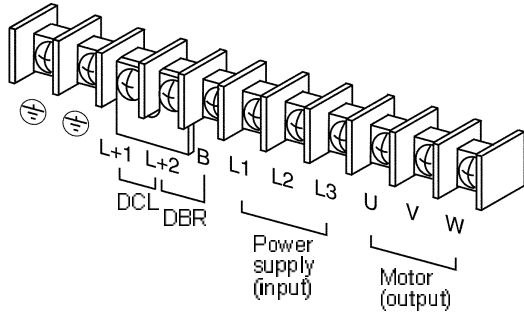

(b) U2KN05K5S - U2KN07K5S  
U2KX05K5S - U2KX07K5S

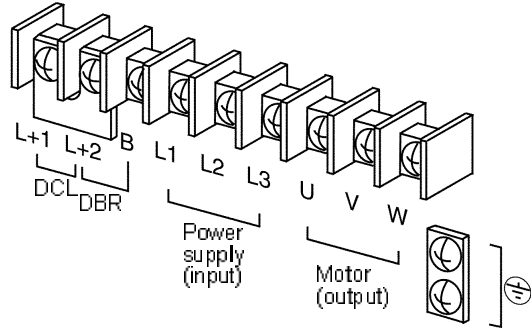

(c) U2KN11K0S - U2KN15K0S  
U2KX11K0S - U2KX18K0S

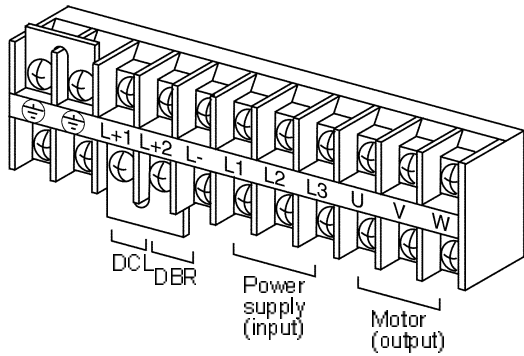

(d) U2KX22K0S

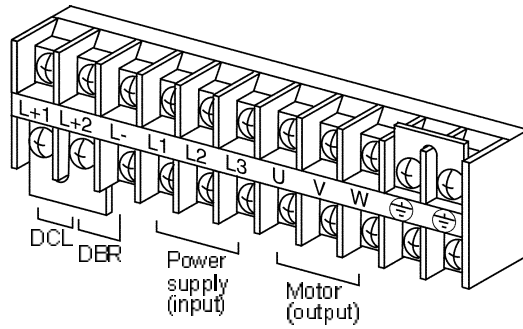

(e) U2KN18K5S - U2KN37K0S  
U2KX30K0S - U2KX45K0S

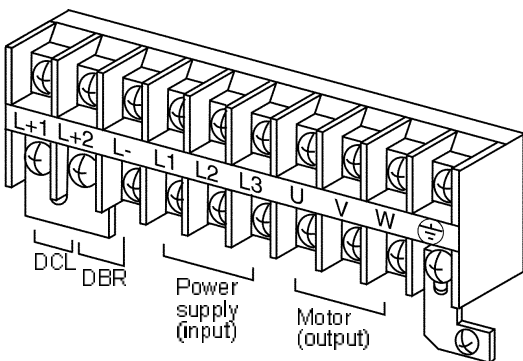

## 2. Installation and Wiring

(f) U2KX55K0S, U2KX75K0S, U2KX90K0S, U2KX110KS

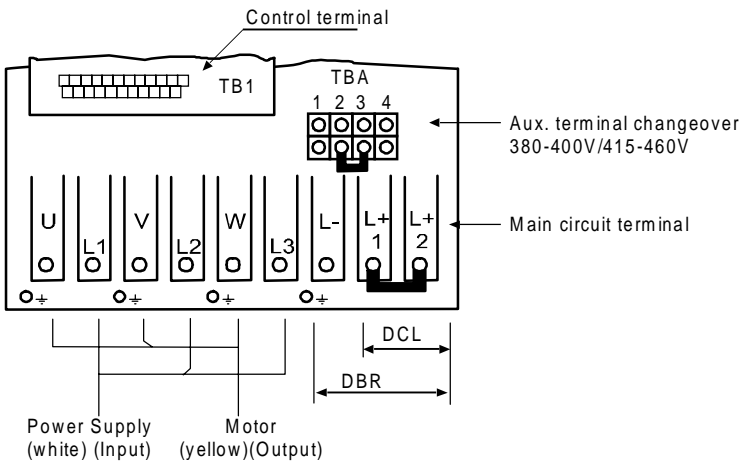

(g) U2KX132KS, U2KX160KS

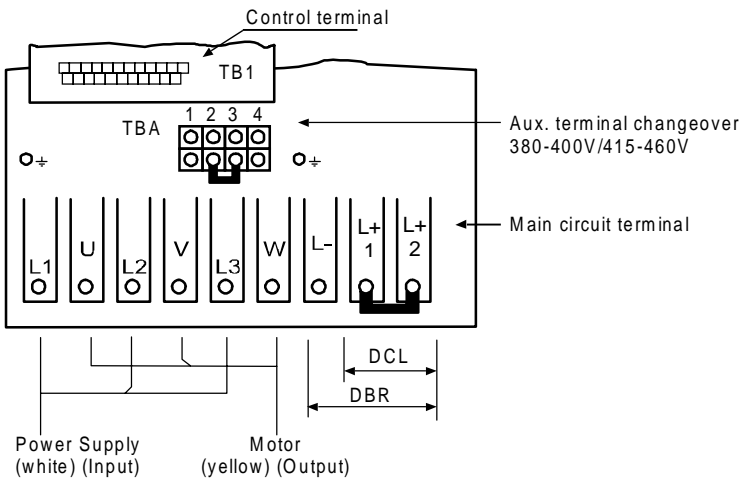

(h) U2KX200KS

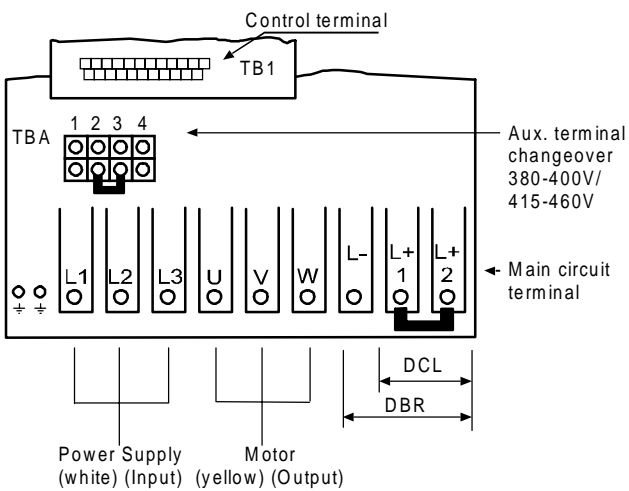

(i) U2KX250KS, U2KX300KS

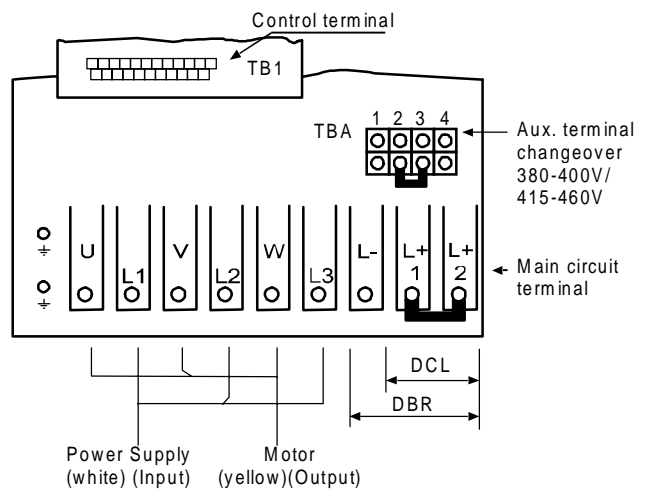

2-4 Precautions for Wiring to the Control Signal

- 1) Separate the main circuit wiring (to terminals L1, L2, L3, L+1, L+2, L-, B, U, V, W) from the other drive wires and power wires.
- 2) Use a 0.25 to 0.75mm<sup>2</sup> wire for wiring to the control circuit. The tightening torque must be 0.6Nm.
- 3) Use a twisted pair wire or twisted pair shield wire for wiring the analog signals (as the setters and meter). (Fig. 2-6.) Connect the shield wire to the TB2 COM terminal of the VAT2000. The wire length must be 30m or less.
- 4) The analog output is dedicated for metering only, such as the speed-meter and ammeter. It cannot be used for control signals such as the feedback control.
- 5) The length of the sequence input/output contact wire must be 50m or less.
- 6) The sequence input (digital I/Os), can be selected either sink logic or source logic method by the short pin (W1). Refer to Table 5-2.
- 7) Observe the precautions listed in "Table 5-2 Control input/output circuit".
- 8) An example of the control circuit wiring is given in Fig. 2-6.
- 9) The layout of the control circuit terminal block is shown in Fig. 2-7; functions are in Table 5-1. Terminals with the same terminal symbol are internally connected.
- 10) After wiring, always check the wiring. Do not test control wirings using a megger or buzzer

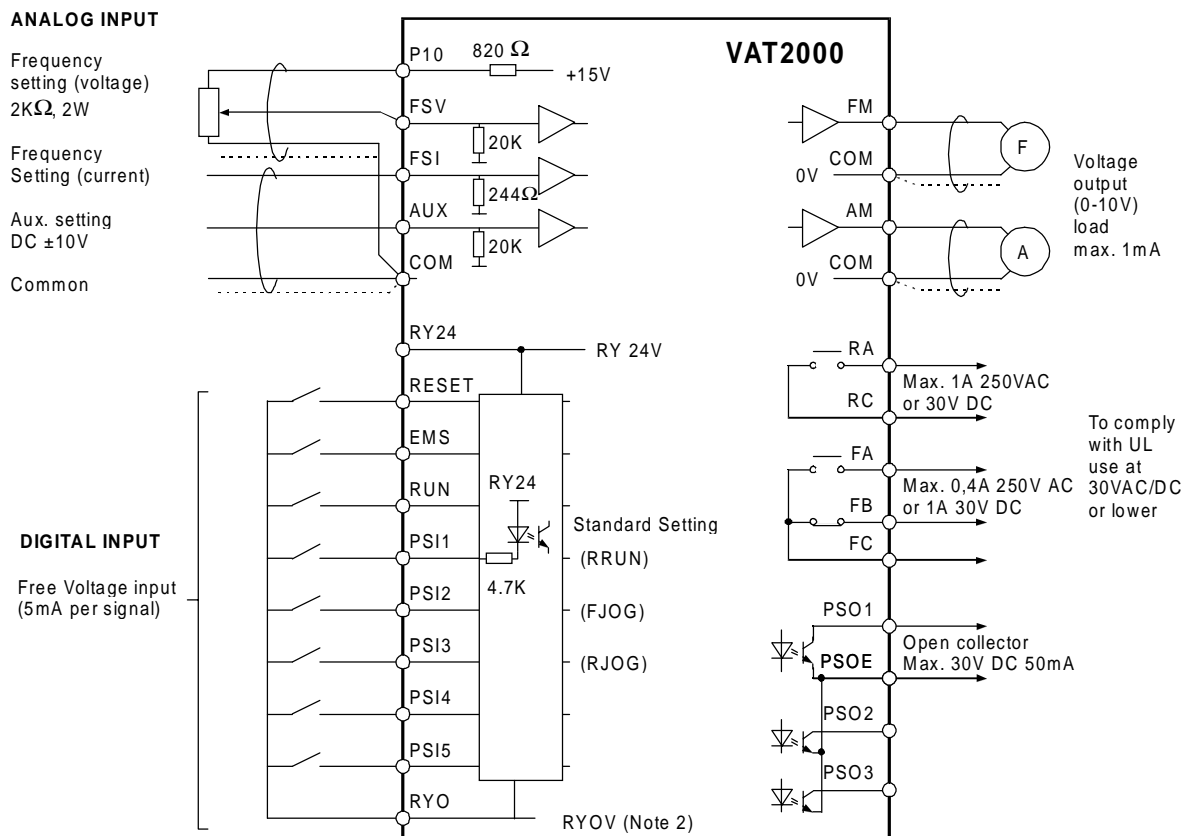

- (Notes)
1. Three COM terminals are internally connected.
  2. No connection shall be made between RY0 and COM since this section is insulated.
  3. This diagram is an example of the sink logic connection. (Refer to Table 5-2.)

Fig. 2-6

• Control terminal (The terminal block is laid out in two rows.)

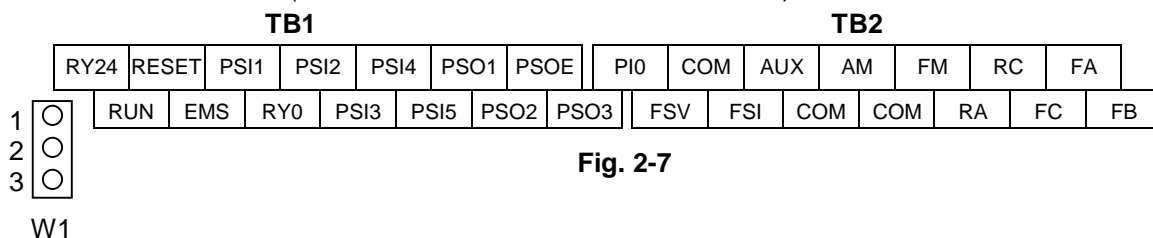

Fig. 2-7

## Chapter 3 Test Operation and Adjustment

### DANGER

- Always install the front cover before turning the input power ON. Never remove the cover while the power is ON. There are sections in the front PCB that are charged with high voltages.  
Failure to observe this could lead to electrical shocks.
- Never touch the switches with wet hands.  
Failure to observe this could lead to electrical shocks.
- Never touch the inverter's terminals while the inverter power is ON even if the operation is stopped.  
Failure to observe this could lead to electrical shocks.
- Selection of the retry function could lead to unexpected restarting when a fault occurs. The machine may start suddenly if the power is turned ON when the automatic start function is selected. Do not go near the machine.  
(Design the machine so that physical safety can be ensured even if the machine restarts.)  
Failure to do so could lead to injuries.
- The machine may not stop when a stop command is issued if the deceleration stop function is selected and the overvoltage / overcurrent limit function is activated. Prepare a separate emergency stop switch.  
Failure to do so could lead to injuries.
- Resetting of a fault while the run signal is input could lead to unexpected restarting. Always confirm that the run signal is OFF before resetting the alarm.  
Failure to do so could lead to injuries.

### CAUTION

- The heat sink and resistor are heated to high temperatures, so never touch them.  
Failure to observe this could lead to burns.
- Do not block the inverter's ventilation holes.  
Failure to observe this could lead to fires.
- The inverter operation can easily be set from low speeds to high speeds, so confirm that the operation is within the tolerable range for the motor or machine before making settings.  
Failure to do so could lead to injuries.
- Prepare holding brakes when necessary. Holding is not possible with the inverter's brake functions.  
Failure to do so could lead to injuries.
- Confirm the operation of the motor as a single unit before operating the machine.  
Failure to do so could lead to injuries or machine damage due to unforeseen movements.  
Always prepare a safety backup device so that the machine is not placed in a hazardous situation when an error occurs in the inverter.  
Failure to do so could lead to injuries or machine damage or fires.

### 3. Test Operation and Adjustment

The VAT2000 has several modes of control. Some of these include settings that must be made according to the power supply and motor constants before actually starting operation. The method to set VAT2000 basic operation is explained in this section.

#### 3-1 Control selection

The VAT2000 has five modes of control, which can be selected with the parameter (C30-0). Refer to Appendix 1 Control Specifications Table for details.



- (1) V/f control (constant torque) (C30-0 = 1) : **(Note 1)**  
V/f control (voltage – frequency control in constant ratio)
- (2) V/f control (variable torque) (C30-0 = 2) : **(Note 1)**  
V/f control (voltage-frequency control in quadratic ratio respect to a variable torque load, such as a fan or pump)
- (3) Speed sensor-less vector control for standard Induction Motors (C30-0 = 3)  
Speed or torque vector control of the IM is achieved without sensor
- (4) Speed sensor vector control for standard Induction Motors (C30-0 = 4) : **(Note 2)**  
Speed or torque vector control of the IM is achieved without sensor.  
This is used when a high speed accuracy or fast torque response is required.
- (5) Permanent Magnet drive control (C30-5 = 5) : **(Note 3)**  
Speed vector control for permanent magnet motors (brush-less type motors).  
The PM motors allow high-efficiency operation in respect to the standard Induction Motors

**(Note 1)** The operation panel only displays the parameters required for each type control. For example, when the V/f control is enabled (C30-0 = 1 or 2) the drive will not display the dedicated parameters for vector control

**(Note 2)** An optional PCB (U2KV23DN1 or DN2) for IM speed detection is necessary. (Table 7-1.)

**(Note 3)** An optional PCB (U2KV23DN3) for PM speed detection is necessary. (Refer to Table 7-1.)

#### 3-2 Selection of operation mode

The VAT2000 operates in both “Local” (from the operation panel) and “Remote” (from I/O terminals) modes. These modes can be changed with the  +  keys while the motor is stopped. The selected mode is confirmed by the LCL LED on the operation panel. Refer to Section 4-1 for details.

For Local Mode : LCL LED ON  
Operation is carried out from the operation panel.

For Remote Mode : LCL LED OFF  
Operation is carried out with the terminal block TB1 input terminals.

#### CAUTION

Make sure that there is no abnormal noise, smoke or odours at this time.  
If any abnormality is found, turn the power OFF immediately.

#### 3-3 Flow of Test Operation

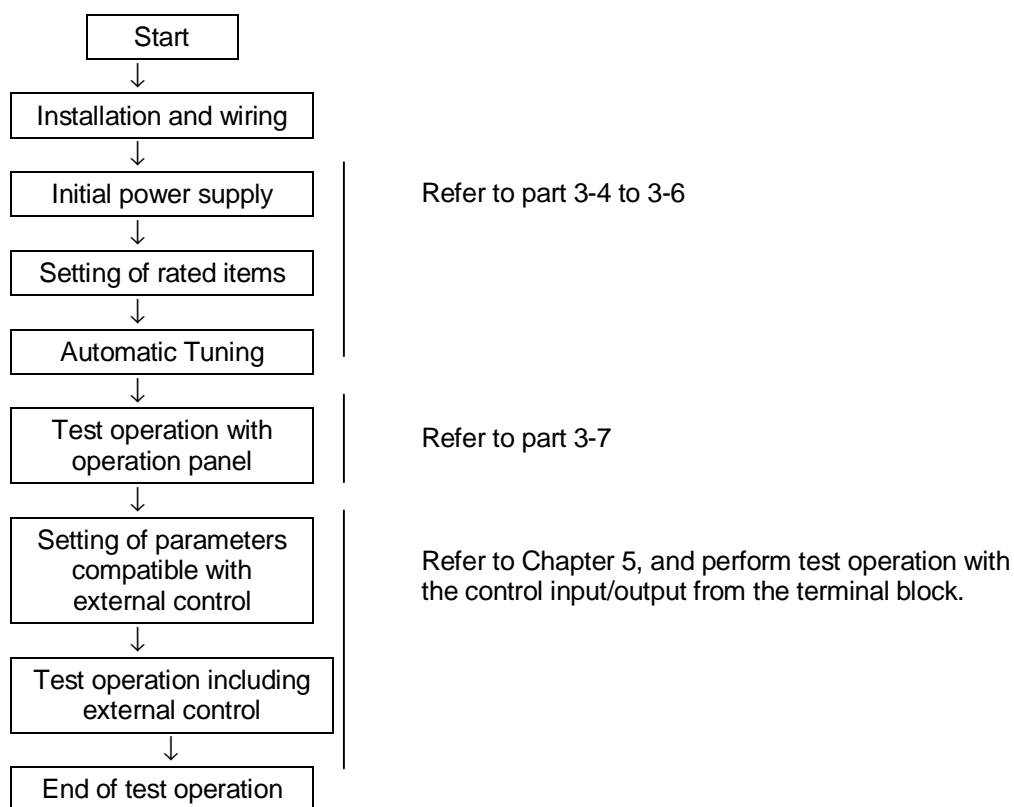

Fig. 3.1 Test operation procedure

#### CAUTION

1. Check that the wiring is correct.
2. The power supply must always be kept in the tolerable range.
3. Always check that the inverter rating and motor rating match.
4. Always correctly install the front cover before turning the power on.
5. Assign one worker to operate the switches, etc.
6. Refer to the Chapter 6 and observe the precautions when changing the set values such as torque boost A02-0.

#### 3-4 Preparation for operation

Always confirm the following points before turning ON the power after completing wire.

- (1) Remove the coupling and belt coupling the motor and machine, so that the machine can be run as a single unit.
- (2) Confirm that the power supply wire is correctly wired to the input terminals (L1, L2, L3).
- (3) When using the 400V Series (X45K0S), confirm that the auxiliary power supply terminal (TBA) short right terminals to match the power supply voltage.  
For 380 to 400V : Link between 2-3 (factory setting)  
For 415 to 480V : Link between 1-2
- (4) Make sure that the power supply is within the tolerable range.
- (5) Make sure that motor is connected with the correct phase order.
- (6) Fix the motor with the specified method.
- (7) Make sure that none of the terminal board screws are loose.
- (8) Make sure that there is no short circuit state in the terminals caused by wire scraps, etc.
- (9) Always correctly install the front cover and outer cover before turning the power ON.
- (10) Assign an operator, and make sure that the operator operates the switches.

#### 3-5 Settings of data before operation

- (1) Turn ON the MCCB, and then turn ON the inverter power.  
All LEDs will light momentarily on the indicator, and then "-----", "□□□-□" will display before displaying "OFF".  
The "LCL" and "Hz" LED will also light.
- (2) Refer to Section 4-5, and confirm the rating parameters.



#### 3-6 Automatic tuning

Automatic tuning measures the constants of the connected motor, and automatically adjusts the parameters so that the system is used to their maximum performance.

VAT2000 automatic tuning can be carried out independently for each of the following types of control.

- V/f control (constant torque) (C30-0 = 1)
- V/f control (variable torque) (C30-0 = 2)
- IM speed sensor-less vector control (C30-0 = 3)
- IM vector control with speed sensor (C30-0 = 4)

**(Note 1)** All parameters belong blocks "B" and "C" -like parameter C30-0- are not displayed as default.  
Check setting in parameter A05-2 prior set parameter C30-0

**(Note 2)** The PM motor control, does not have a specific Automatic tuning. Refer to 6-8 for details

### 3. Test Operation and Adjustment

---

#### 3-6-1 V/f control (constant torque) (C30-0 = 1), V/f control (variable torque) (C30-0 = 2) automatic tuning

##### (1) Automatic tuning

The Auto-tuning for V/f control (constant torque) or V/f control (variable torque) can be performed in two modes, basic or extended. The mode selection is allowed by parameter (B19-0). **(Note 1, 2)**

- 1) B19-0 = 1: Mode 1: V/f control basic adjustment mode (Execution time: approx. 10 seconds).

The drive automatically adjusts basic parameters, such as boost voltage and brake voltage. In this phase the motor does not rotate.

The following parameters are automatically adjusted by executing Mode 1.

**Table 3-6-1**

Parameter No.	Name
A02-2	Manual torque boost setting
A03-0	DC brake voltage
B02-0, 1	R1: Primary resistance

- 2) B19-0 = 2: Mode 2: V/f control extended adjustment mode (Execution time: approx. 1min.). Use this method if the motor is completely unloaded only. (No load at motor shaft)

The drive automatically adjusts parameters related to the slip compensation and max. torque boost. In this phase the motor rotate.

The following parameters are automatically adjusted by executing Mode 2.

**Table 3-6-2**

Parameter No.	Name
A02-2	Manual torque boost setting
A03-0	DC brake voltage
B02-0, 1	R1: Primary resistance
A02-5	Slip compensation gain
A02-6	Max. torque boost gain

**(Note 1)** The automatic tuning function (B19-0) cannot be used in modes other than control selected with the parameter (C30-0). When C30-0 is set to 1 or 2, the following cannot be selected.

B19-0 = 3: Mode 3: Vector control basic adjustment mode

B19-0 = 4: Mode 4: Vector control extended adjustment mode

**(Note 2)** If the base frequency of the motor is applied on a motor exceeding 120Hz, select Mode 1 (B19-0 = 1). Adjust the slip compensation gain (A02-5) and max. torque boost gain (A02-6) manually.

#### CAUTION

##### Precautions for executing V/f control (constant torque) V/f control (variable torque) automatic tuning

- During automatic tuning, the motor may rotate, so always confirm safety before starting automatic tuning.
- Separate the motor from the load and machine, etc., and run the motor as a stand alone unit during automatic tuning.
- Even when Mode 1 is executed, the motor may rotate due to vibration, etc.  
If the vibration is large, turn the  key immediately to stop operation.
- Always check the safety on the load side before executing automatic tuning, regardless of the Mode 1 or 2 setting.  
With Mode 2, the motor will automatically start rotating.
- If the automatic tuning function does not end correctly, always turn the inverter power OFF before investigating or confirming the operation.
- Automatic tuning can be carried out only in the Local Mode.
- If the motor has an unstable frequency band, automatic tuning may not end normally. In this case, the maximum torque boost function cannot be used.
- Always ground the motor and inverter.
- If the load is less than 30% and the fluctuation does not occur, automatic tuning can be carried out with the load and machine connected. However, the performance may not be complete.
- Always carry out automatic tuning before using the maximum torque boost function.
- The contact output FLT will function if the automatic tuning does not end correctly. In equipment that uses this contact, keep the operation of the related devices in mind.

**(2) Automatic tuning operation procedures**

The automatic tuning is carried out according the following procedure.

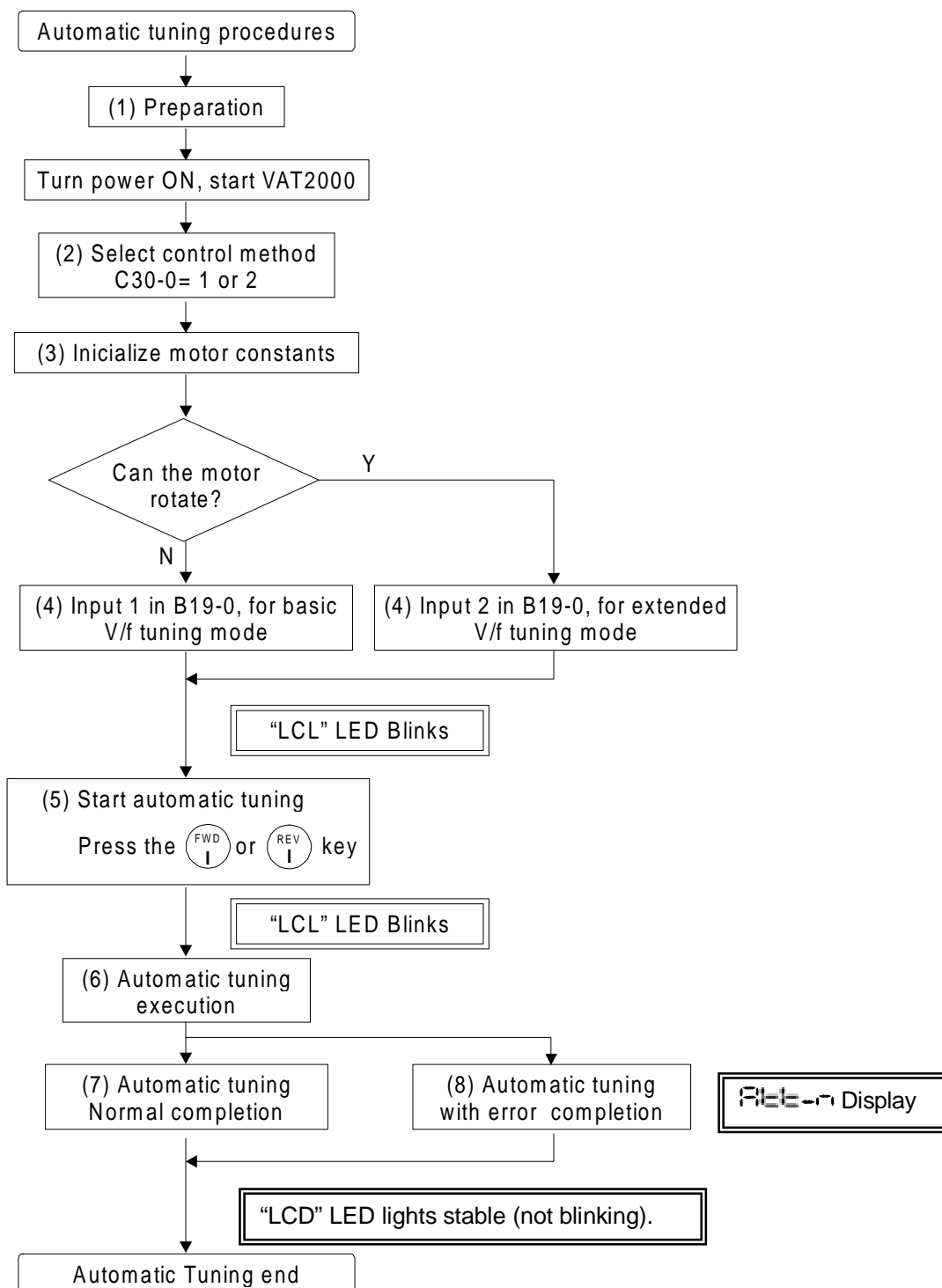

**Fig. 3-2 Auto-tuning procedure for V/f control (Constant Torque and Variable Torque)**

### 3. Test Operation and Adjustment

#### 1) Preparation

Separate the motor and load, machine, etc., and confirm the safety on the load side.

#### 2) Selection of control method

- Set A05-2 to 1. (enables parameter display)
- By parameter (C30-0), select V/f control according the load conditions
  - V/f control (constant torque) (C30-0 = 1) ( Default value)
  - V/f control (variable torque) (C30-0 = 2)

#### 3) Initialisation of motor constants



Input the motor rating nameplate value parameters. Automatic tuning will automatically change the parameters shown in table 3-6-1 or table 3-6-2.

**Table 3-6-3**



Parameter No.	Name	
B00-0	Rated input voltage setting	[V]
B00-1	Max/base frequency simple setting	[Hz]
B00-2	Motor rated output	[kW]
B00-3	Rated output voltage	[V]
B00-4	Max. frequency	[Hz]
B00-5	Base frequency	[Hz]
B00-6	Motor rated current	[A]
B00-7	Carrier frequency	[kHz]



\* The max. frequency cannot be set below the base frequency, and the base frequency cannot be set above the max. frequency.

#### 4) Selection of automatic tuning function

- Set A05-0 to 1. (enables parameter display)
- By parameter (B19-0), select the automatic tuning mode according working conditions. Refer to section 3-6-1 for details.
- The automatic tuning will star when the  key is pressed.
- During the automatic tuning state, the LCL LED will blink.
- To abort the automatic tuning, press the  key.

#### 5) Starting automatic tuning

Automatic tuning will start when either the  key or  key is pressed according to the required rotation direction. A message indicating starting will appear on the operation panel. To stop, press the  key or input the emergency stop signal (EMS) from the terminal block.

\* Keys other than  and  are disabled during automatic tuning.

#### 6) During automatic tuning execution

The progression state can be shown by parameter display D22-0. Refer to section 3-6-4 for details.

#### 7) Normal completion of automatic tuning

The "LCL" LED will end blinking, lighting stable, and a message indicating the end will be displayed. Refer to section 3-6-1 for the adjustment details.

#### 8) Abnormal completion of automatic tuning

If the automatic tuning ends abnormally, a error message will appear. Check according to the error codes. Refer to section 3-6-3 for details.

### 3. Test Operation and Adjustment

#### 3-6-2 IM speed sensor-less vector control (C30-0 = 3) and IM vector control with speed sensor (C30-0 = 4) automatic tuning

##### (1) Automatic tuning

The Auto-tuning for the IM speed sensor-less vector control or IM vector control with speed sensor can be performed in two modes, basic or extended. The mode selection is allowed by parameter (B19-0). **(Note 1)**

- 1) B19-0 = 3: Mode 3: Vector control basic adjustment mode (Execution time: approx. 30 seconds)

The drive automatically adjusts basic parameters for vector control.

The following parameters are automatically adjusted by executing Mode 3.

**Table 3-6-4**

Parameter No.	Name
B01-8	No-load output voltage
B02-0, 1	R1 : Primary resistance
B02-2, 3	R2 : Secondary resistance
B02-4, 5	$L\sigma$ : Leakage inductance
B02-6, 7	$M'$ : Excitation inductance

- 2) B19-0 = 4: Mode 4: Vector control expanded adjustment mode (Execution time: approx. 1 minute)

This mode is selected for constant power range operation only. **(Note 2)**

The following parameters are automatically adjusted by executing Mode 4.

**Table 3-6-5**

Parameter No.	Name
B01-9	No-load output voltage
B02-0, 1	R1 : Primary resistance
B02-2, 3	R2 : Secondary resistance
B02-4, 5	$L\sigma$ : Leakage inductance
B02-6, 7	$M'$ : Excitation inductance
B34-0 to 7	M variable compensation table

**(Note 1)** The automatic tuning function (B19-0) cannot be used in modes other than control selected with the parameter (C30-0). When C30-0 is set to 3 or 4, the following cannot be selected.

B19-0 = 1: Mode 1: V/f control basic adjustment mode

B19-0 = 2: Mode 2: V/f control extended adjustment mode

**(Note 2)** When the motor works under constant power operation, the excitation inductance fluctuation must be compensated.

Assign the operation range to the reference speed table in B33-0 to 7.

Note that the motor will rotate to the max. speed in this case, so take special care to safety.

- 3) B19-0 = 5: Mode 5: Vector control adjustment mode when load exceed of 10%

When the load is higher than 10% or there are fluctuations, is possible to perform Autotuning following procedure shown below,

- 1 Adjust manually motor equivalent data parameters B02-0 to 9. R1: primary resistance, R2': Secondary resistance,  $L\sigma$ : Leakage inductance,  $M'$ : Excitation inductance.
- 2 Execute Autotuning procedure shown in page 3-11, but entering 5 in parameter B19-0.

Autotuning adjust the no load voltage parameter, improving Vector performance from manual adjustment

### 3. Test Operation and Adjustment

#### CAUTION

##### **Precautions for executing IM speed sensor-less vector control or IM vector control with speed sensor automatic tuning**

- During automatic tuning, the motor may rotate, so always confirm safety before starting automatic tuning.
- Separate the motor from the load and machine, etc., and run the motor as a stand alone unit during automatic tuning.
- The motor may vibrate and rotate during automatic tuning.  
If the vibration is large, turn the  key immediately to stop operation.
- Always check the safety on the load side before executing automatic tuning. The motor will automatically start rotating during automatic tuning.
- If the automatic tuning function does not end correctly, always turn the inverter power OFF before investigating or confirming the operation.
- Automatic tuning can be carried out only in the Local Mode.
- Always ground the motor and inverter.
- If the load is less than 10% and the fluctuation does not occur, automatic tuning can be carried out with the load and machine connected. However, the performance may not be complete.
- If the load is higher than 10% or the fluctuation occur, automatic tuning can be carried out entering motor data manually and setting B19-0=5. Chek section 3-6-2
- The contact output FLT will function if the automatic tuning does not end correctly. In equipment that uses this contact, keep the operation of the related devices in mind.

(2) Automatic tuning operation procedures

The automatic tuning is carried out according the following procedure.

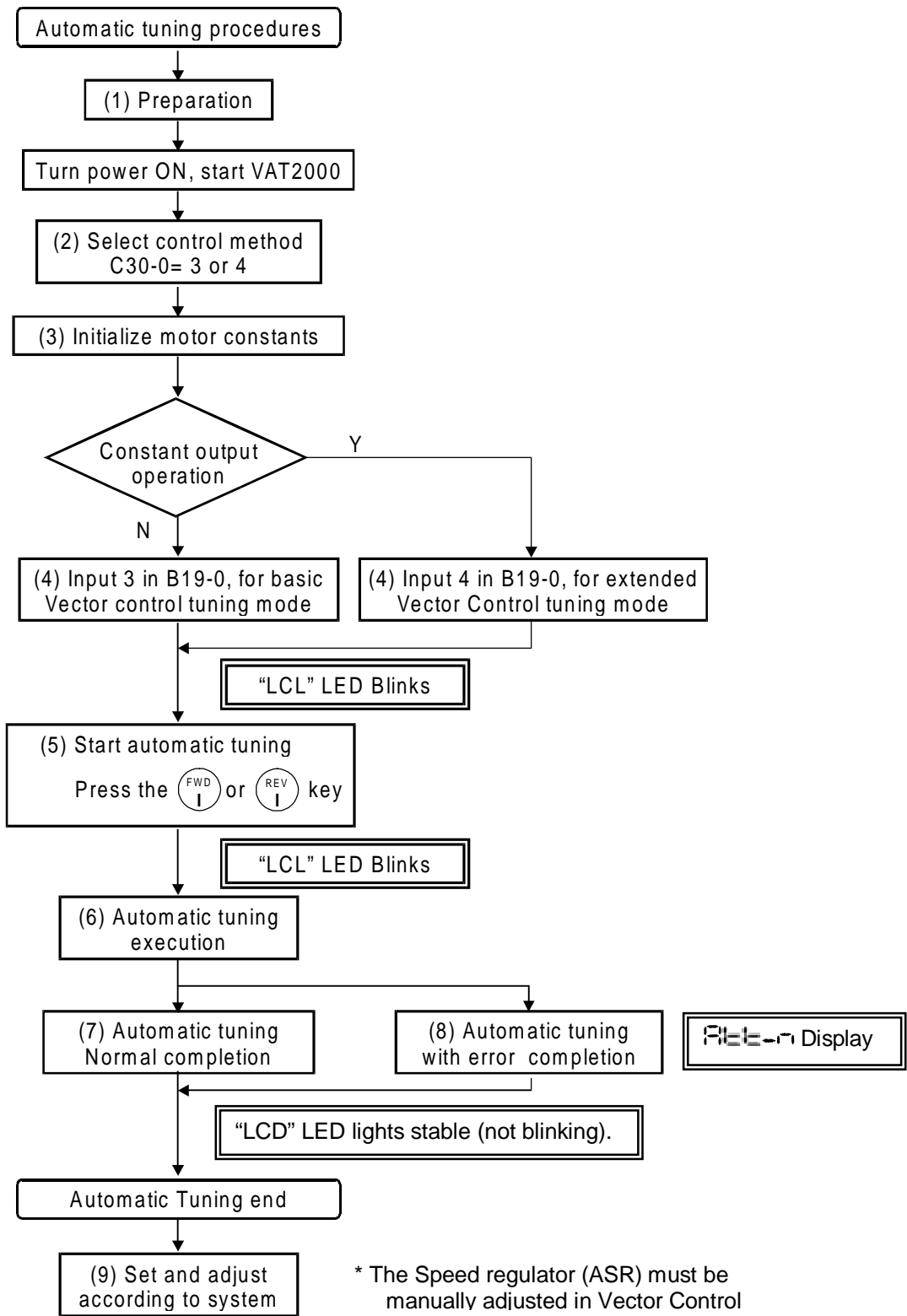

Fig. 3-3 Automatic tuning procedures for sensor or sensorless vector control (for Induction motors)

### 3. Test Operation and Adjustment

#### 1) Preparation

Separate the motor and load, machine, etc., and confirm the safety on the load side.

#### 2) Selection of control method

- Set A05-2 to 1. (enables parameter display)
- By parameter (C30-0), select V/f control according the load conditions

IM speed sensor-less vector control (C30-0 = 3), ( Default value)

IM vector control with speed sensor (C30-0 = 4)

\* The default value is V/f control (constant torque) (C30-0 = 1).

#### 3) Initialisation of motor constants

Input the motor rating nameplate value parameters. Automatic tuning will automatically change the parameters, so it is recommended to write down the values set in table 3-6-4 or table 3-6-5.

Table 3-6-6

Parameter No.	Name	
B01-0	Rated input voltage setting	[V]
B01-1	Motor rated output	[kW]
B01-2	No. of motor poles	[Pole]
B01-3	Rated output voltage	[V]
B01-4	Max. speed	[min <sup>-1</sup> ]
B01-5	Base speed	[min <sup>-1</sup> ]
B01-6	Motor rated current	[A]
B01-7	Carrier frequency	[kHz] : <b>(Note 1)</b>
B01-8	No. of encoder pulses	[P/R] : <b>(Note 2)</b>

\* When the motor works under constant power operation, the excitation inductance fluctuation must be compensated.

Assign the operation range to the table reference speed in B33-0 to 7.

Note that the motor will rotate to the max. speed in this case, so take special care to safety.

\* The max. speed cannot be set below the base speed, and the base speed cannot be set above the max. speed.

**(Note 1)** During IM speed sensor-less vector control (C30-0 = 3), it is recommended to set the carrier frequency to 10KHz to improve the current detection accuracy.

**(Note 2)** Always enter encoder pulse numbers when using the speed sensor.

#### 4) Selection of automatic tuning function

- Set A05-0 to 1. (enables parameter display)
- By parameter (B19-0), select the automatic tuning mode according working conditions. Refer to section 3-6-2 for details.



• The automatic tuning will star when the  key is pressed.

• During the automatic tuning state, the LCL LED will blink.



• To abort the automatic tuning standby state, press the  key.

### 3. Test Operation and Adjustment

#### 5) Starting automatic tuning

Automatic tuning will start when the  key or  key is pressed according to the required rotation direction. A message indicating starting will appear on the operation panel.

To stop, press the  key or input the emergency stop signal (EMS) from the terminal block.

\* Keys other than  and  are disabled during automatic tuning.

#### 6) During automatic tuning execution

The progression state can be confirmed with D22-0.  
Refer to section 3-6-4 for details.

#### 7) Normal completion of automatic tuning

The "LCL" LED will end blinking, lighting stable, and a message indicating the end will be displayed. Refer to section 3-6-2 for the adjustment items.

#### 8) Abnormal completion of automatic tuning

If the automatic tuning ends abnormally, a message will appear. Investigate and check according to the error codes. Refer to section 3-6-3 for details on the error codes.

#### 9) Additional settings and adjustments

There are some parameter related to load condition or required response control which should be adjusted manually. The main parameters are shown below.

- A10-0: ASR response : Set the speed control response in [rad/s] unit.  
If the speed tracking is slow, increase this value.  
Note that if this value is too high, hunting may occur.
- A10-1: Machine time constant 1 : Set the time required to accelerate from zero to the base speed with the rated torque.

$$T_m [\text{msec}] = 10.968 \times J [\text{kgm}^2] \times N_{\text{base}} [\text{rpm}] / \text{Power} [\text{W}]$$

J : Total inertia [kgm<sup>2</sup>]  
N base : Base speed [rpm]

- A10-2: Integral time constant compensation coefficient:  
Increase the compensation coefficient if the overshooting is high during speed control.
- A10-3: ASR drive torque limit : Increase if a higher drive torque is required.
- A10-4: ASR regenerative torque limit : Increase if a higher regenerative torque is required.

#### 9) Adjustment for Induction Motor, sensorless vector control

Adjust the following items, to improve accuracy

##### • Fine adjustment of primary resistance

With motor unloaded, run the motor at the minimum speed to be used, and finely adjust the primary resistance (B02-0,1). For Forward run, adjust so that D11-4 (ASR output) is near zero on the positive side. (Note that B02-0 can be set during run but B02-1 can not)  
Make sure that the D11-4 does not reach the negative side during forward run.

##### • Adjustment of estimated speed integral gain

Confirm that D00-3 (motor speed on % units) is stable ( $\pm 1\%$  or less) during trial operation. If not decrease (approx. half) the speed estimated proportional gain (B31-1)

### 3. Test Operation and Adjustment

#### 3-6-3 Automatic tuning error messages

If automatic tuning ends abnormally, the drive will display an error code,  $\text{P}18\text{-}n$ . The error codes “n” are defined in the below table.

Code	Cause and remedy
n=1	1. The motor may not be connected correctly. Check motor connections. 2. The B00 or B01 parameters may not be set correctly Check the parameter setting.
n=2	1. The B00 or B01 parameters may not be set correctly Check the parameter setting..
n=3	1. The motor may not be separated from the load. Separate the motor from the load 2. Increase the acceleration ramp time (A01-0) 3. Decrease the acceleration ramp time (A01-1) 4. If the motor vibrates, increase the torque stabilising gain (B18-2)
n=4	1. The motor may not be separated from the load. Separate the motor from the load 2. If the motor vibrates, increase the torque stabilising gain (B18-2)
n=5	<u>When the motor does not stop:</u> 1. Increase the acceleration/deceleration ramp time A01-0, A01-1 <u>When the motor stops:</u> 1. The B00 or B01 parameters may not be set correctly Check the parameter setting.
n=6	1. The B00 or B01 parameters may not be set correctly Check the parameter setting.

#### 3-6-4 Automatic tuning progression state display

Details on the progression state of automatic tuning can be confirmed with the monitor parameter: D22-0 display.

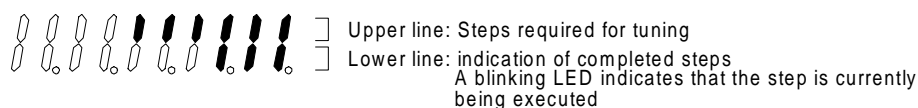

#### 3-7 Test operation with operation panel

The test operation with the operation panel is performed with the following procedure.

#### CAUTION

Make sure that input signals to digital Inputs, RUN, EMS, PSI1 ~ 5 terminals are OFF

- (1) Turn ON the power supply.  
 All LEDs will light momentarily on the display, and then "•••••", "A00-0" and "0FF". will be sequentially displayed.  
 The "LCL" and "Hz" LED will also light.  
 Set the parameter C02-0 to 3 (panel fixed); it will enable the speed setting from the operation panel. Refer to section 4-5 for details on changing the parameters.







#### CAUTION

The motor will run. Confirm the safety around the motor before start



- (2) Press the  key.  
 The "FDW" LED will light and the display will change from "0FF" to "10.00". This is because the local setting frequency (A00-0) is set to 10Hz as the default setting.

#### CHECK



1. Did the motor run?  
 2. Is the run direction correct? Check the wiring and operation if abnormal.  
 3. Is the rotation smooth?

- (3) Press the  key and confirm that the motor runs in reverse.
- (4) Press the  key and stop the motor.
- (5) Press the  key. The motor will forward run at 10Hz.
- (6) Press the  key once. The display will alternate between "A00-0" and "10.00".
- (7) Press the  key once.

The display will stop at "10.00", and the last digit will blink. Now the value set in parameter A00-0 may be changed.



The digit to change can be selected with the  key. The output frequency (digit value) can be increased / decreased with the  knob.

### 3. Test Operation and Adjustment

- (8) Move the digit with the  key, and using the  knob, raise the frequency to 50Hz. Then, press the  key. The new value is stored and output frequency will rise to 50Hz.

#### CAUTION

A 10-second acceleration and 20-second deceleration ramp time are set as defaults. The motor will slowly increase its speed to the set value. Increase the speed by approx. 10Hz steps at a time with the  knob.

- (9) Press the  key when the motor speed reaches 50Hz. The display will decrease to 0.00 in 20 seconds. The "FWD" or "REV" LED will blink for two seconds while the DC-brake is applied and the motor will stop.
- (10) Press the  key to test the reverse run.

This completes the test operation with the operation panel.  
Refer to Chapter 4 and make the adjustments according to the user application.

## Chapter 4 Operation Panel

### 4-1 Details of operation panel

The configuration of the operation panel is shown in Fig. 4-1.

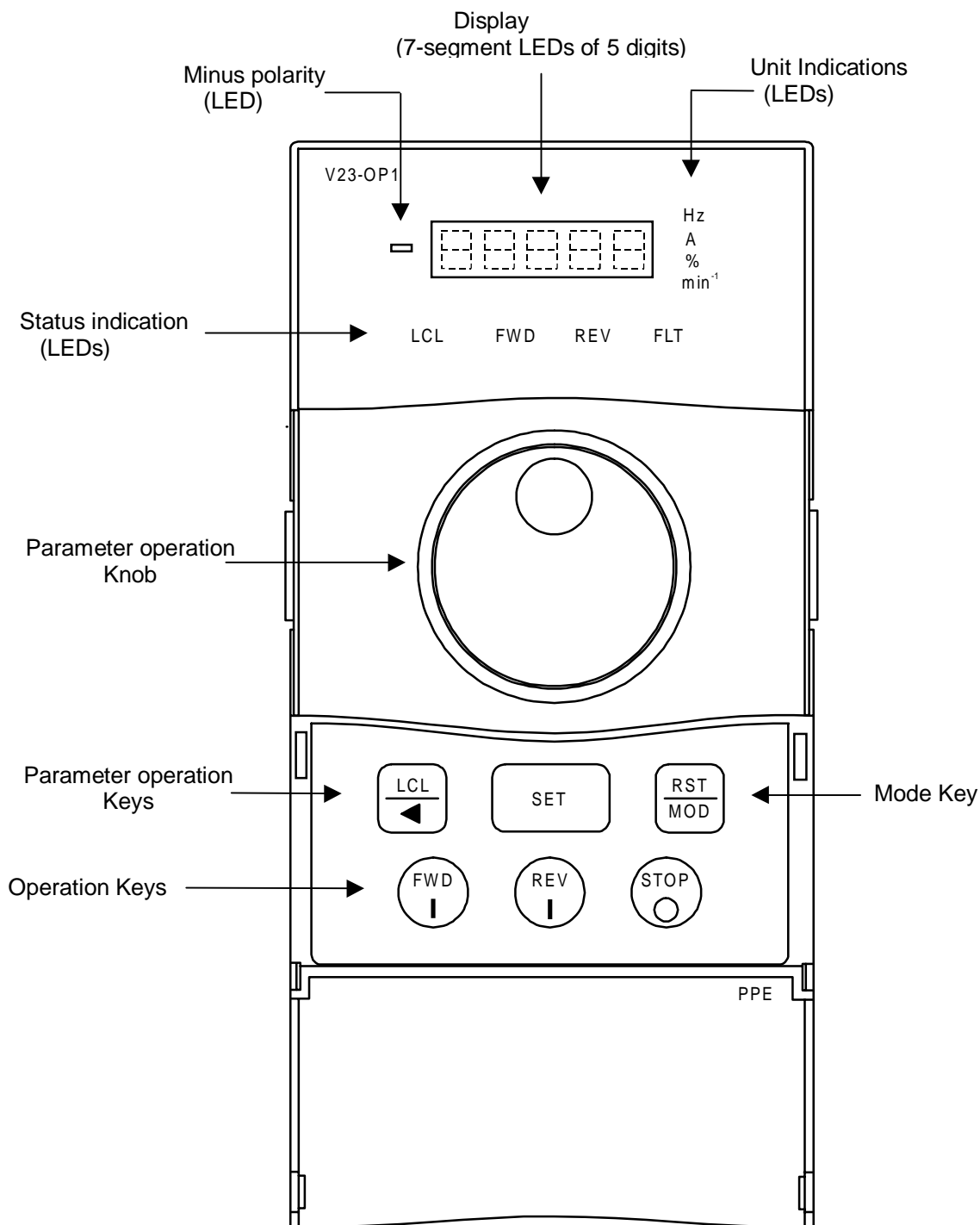

Fig. 4-1

## 4. Operation Panel (Keypad)

The functions of each section are shown in Table 4-1.

**Table 4-1 Functions of operation panel**

Status indications LEDs		
<b>FWD (Forward)</b>	The drive is running in the forward direction.	When both LED's blink simultaneously, it indicates that DC Brake or pre-excitation is in action. If only the "FWD" or "REV" LED blinks, this indicates that a command in the reverse direction has been received, and the drive is decelerating.
<b>REV (Reverse)</b>	The drive is running in the reverse direction.	
<b>FLT (Fault)</b>	The drive has detected a fault and has stopped. The drive can be reset from the Operation Panel (STOP + RST/MOD) or from the terminal block (RESET signal).	
<b>LCL (Local)</b>	The drive is in the Local Mode and can be operated from the Operation Panel (FWD, REV and STOP only). When "LCL" LED is off, the drive is in the Remote Mode and can be controlled from the terminal block (sequence input signals). To change Modes between Local and Remote, press  + .	
Unit indication LEDs		
<b>HzA%min<sup>-1</sup></b>	Indicates the unit of the parameter value shown on the display.	
Minus polarity indication LED		
—	Lights for negative numbers.	
Operation keys		
	Starts the drive in the forward direction. (in Local Mode only)	
	Starts the drive in the reverse direction. (in Local Mode only)	
	Stops the drive. The motor will either coast to a stop or ramp down to a stop as selected on C00-1.	
	Changes control Modes from Local to Remote, or vice-versa. When the drive is in Local Mode, "LCL" LED is on. <b>(Note)</b>	
	Resets a fault, FLT LED changes to OFF.	
Parameter operation keys Parameter operation knob		
(Mode)	Changes display blocks sequentially in the following order. Monitor, Parameter-A, Parameter-B, Parameter-C, Utility mode-U	
	Fixes Parameter number or set its values.	
	Increases Parameter Block. Increases Parameter Number or its values.	
	Decreases Parameter Block. Decreases Parameter Number or its values.	
	Param. select	Changes Parameter Block for the desired Parameter. To change to the next Block up, turn  first. For the next Block down, turn  first.
	Value change	Moves the cursor to the desired digit for adjustment. The cursor is on the blinking digit.

**(Note)** As default the drive is set so that a Local/Remote selection is disabled while the drive is running. Even while the drive is at a stop, changeover cannot be made if operating commands such as RUN, JOG, etc., are ON at the terminal board. This lock can be released by parameter C09-2.

4-2 Modes and parameters

The parameters to be used differ depending of the control mode (C30-0). The parameters included are for the V/f control (constant torque and variable torque), IM vector control (sensor-less and with sensor for induction motors) and PM vector control (for PM motors).

These parameters are grouped into Modes and Blocks according to their functions and frequency of usage.

4-2-1 V/f control (constant torque) and V/f control (variable torque)

The configuration of the parameters is shown in Fig. 4-2.

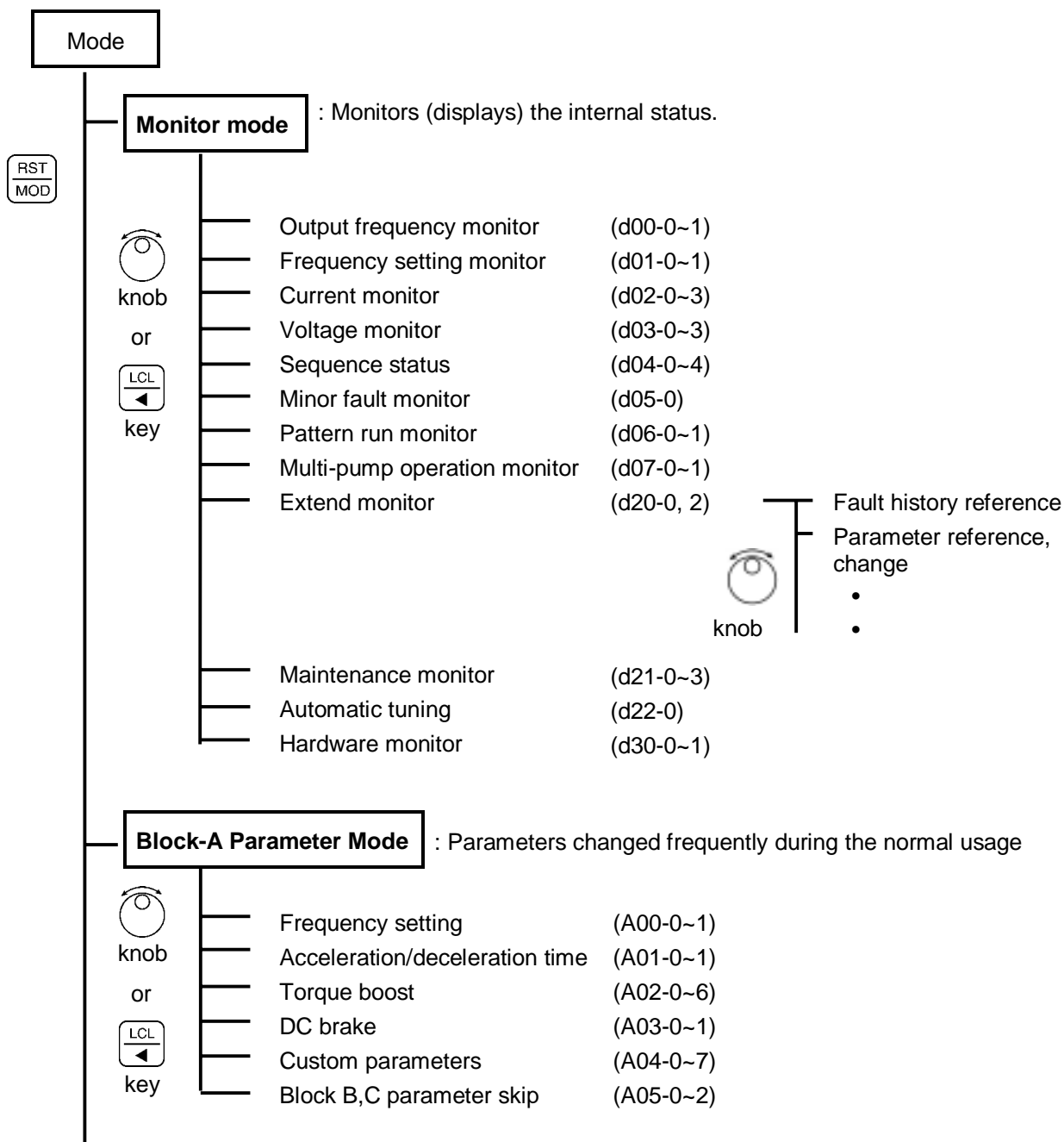

(Continued on next page)

Fig. 4-2 (1) Parameter configuration

## 4. Operation Panel (Keypad)

(Continued from previous page)

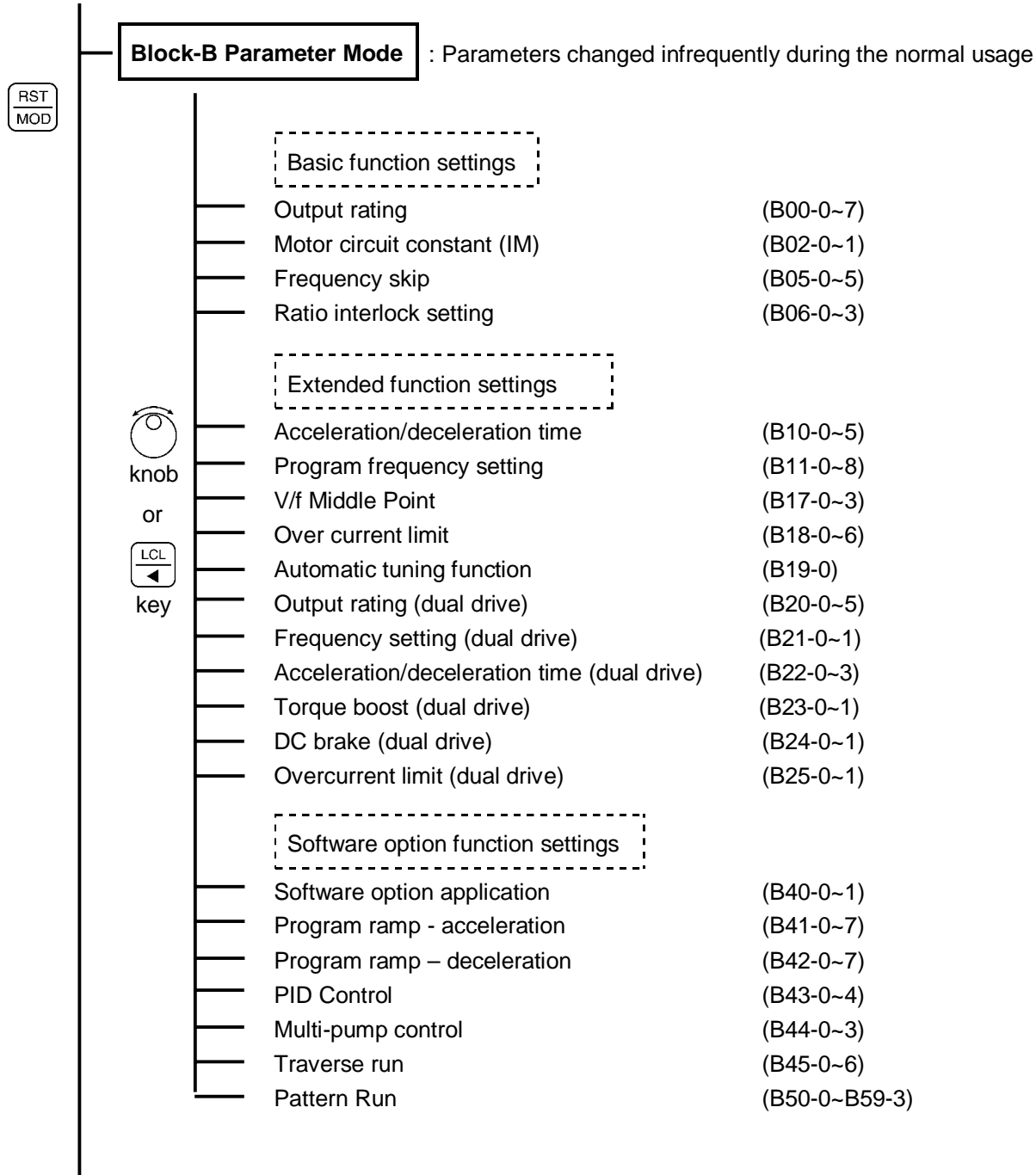

(Continued on next page)

**Fig. 4-2 (2) Parameter configuration**

## 4. Operation Panel (Keypad)

(Continued from previous page)

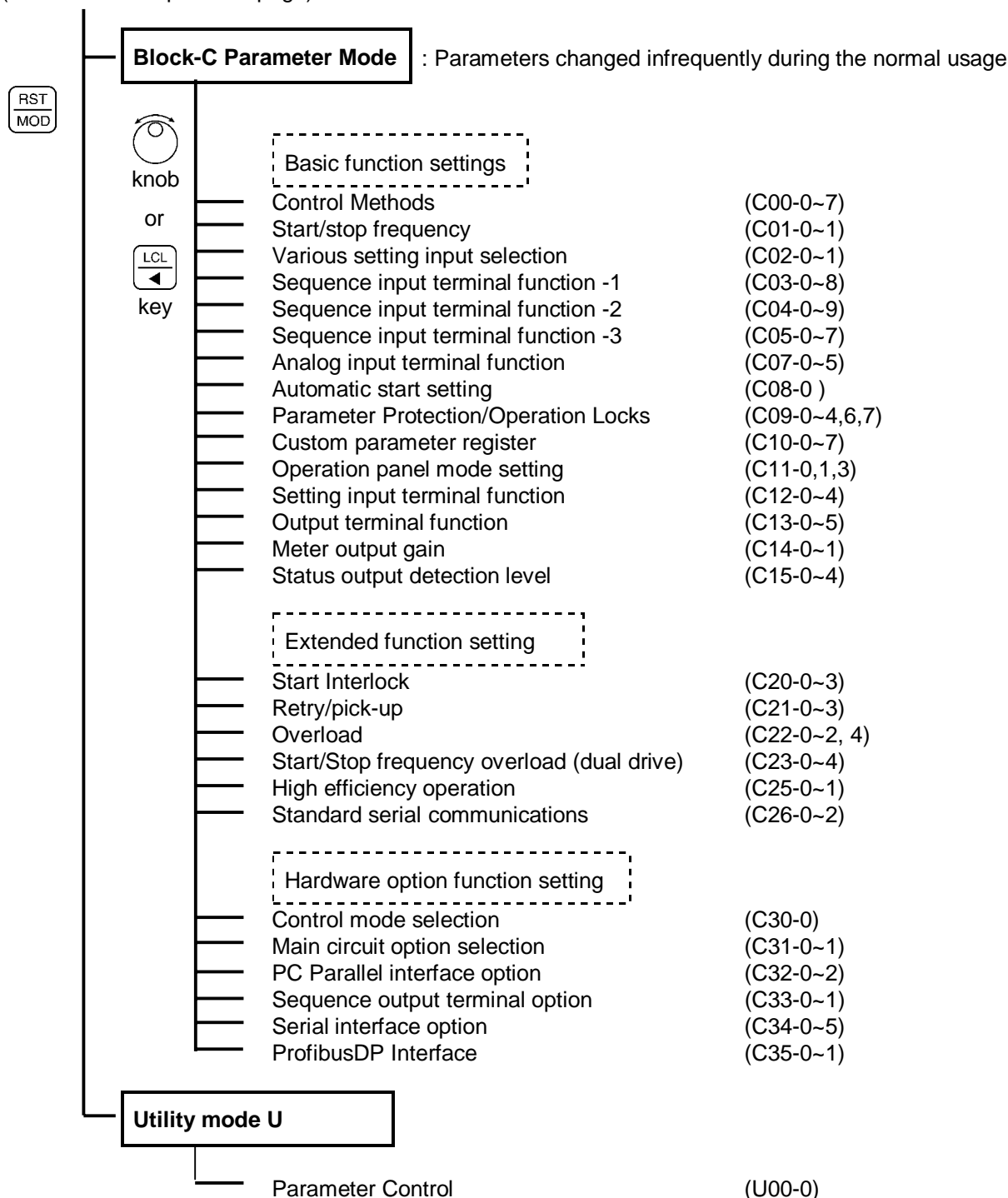

**(Note)** At the default setting, only the basic functions are displayed, but the extended function, software option function, hardware option function parameters are skipped. Thus, to display these parameters, change parameter A05-0 to 3 (parameter B, C block skip setting), so that the target parameters are displayed.

**Fig. 4-2 (3) Parameter configuration**

4-2-2 Speed sensorless vector control, and vector control with speed sensor (IM)

The configuration of the parameters is shown in Fig. 4-3.

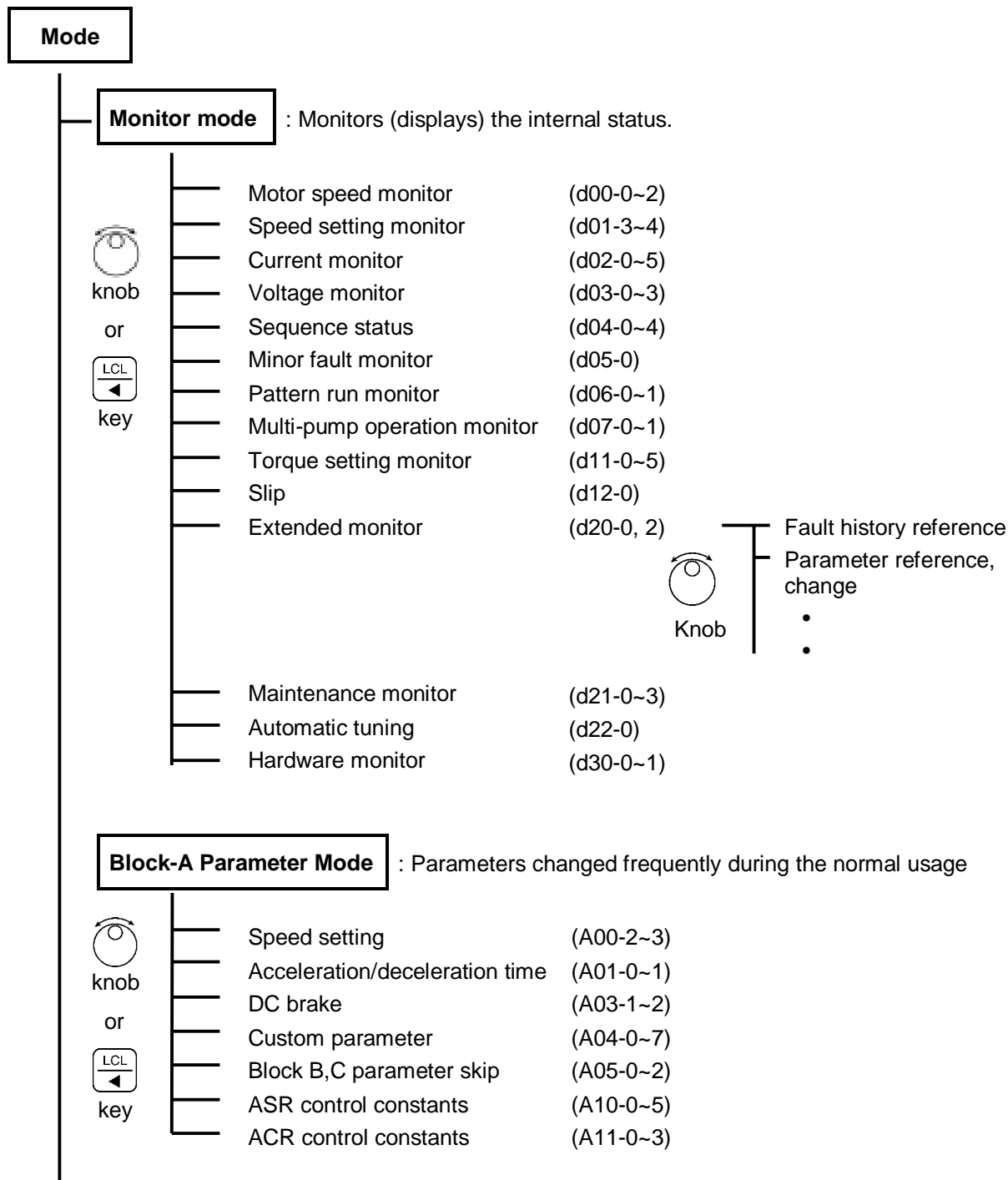

(Continued on next page)

Fig. 4-3 (1) Parameter configuration

## 4. Operation Panel (Keypad)

(Continued from previous page)

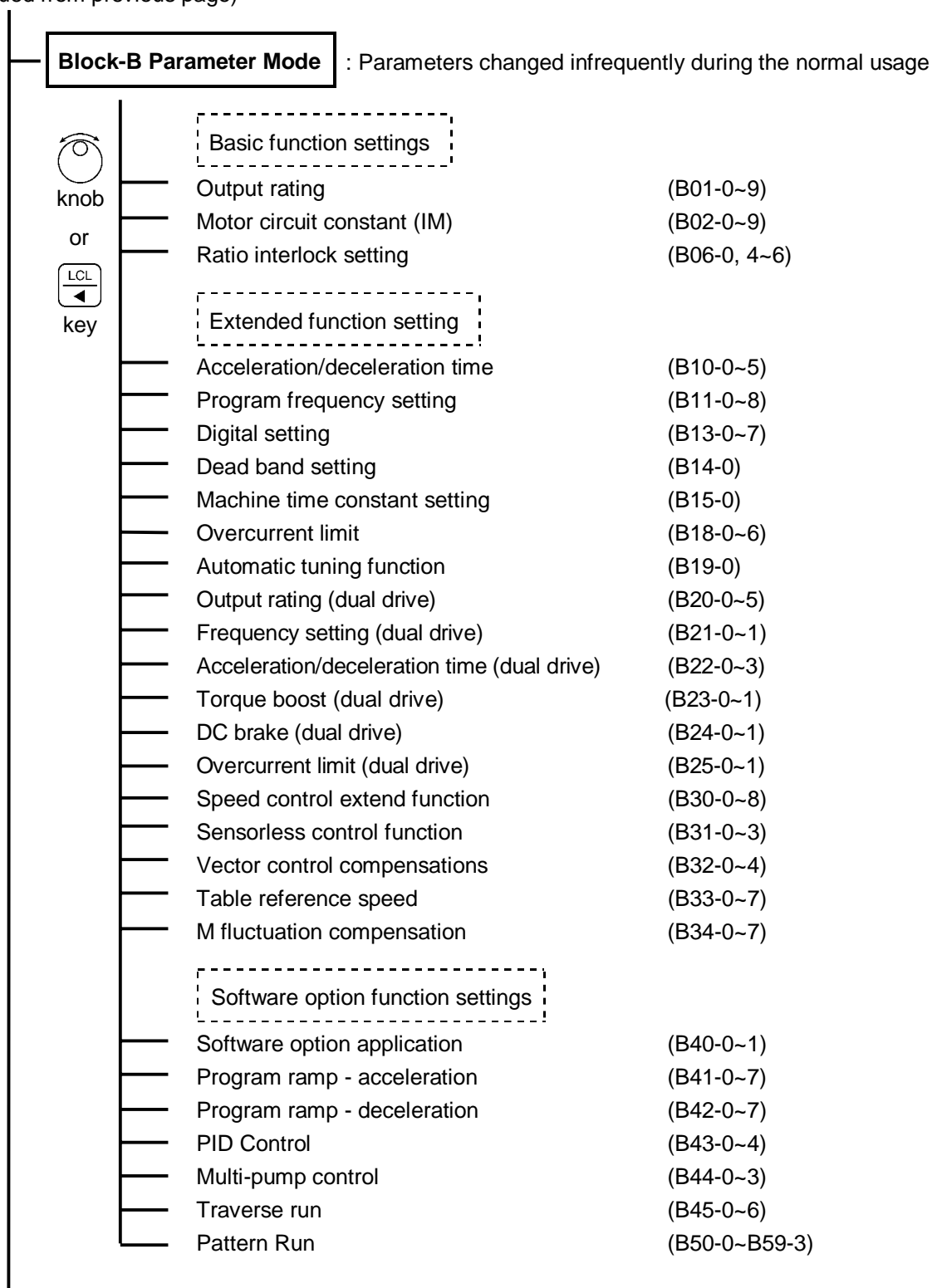

(Continued on next page)

**Fig. 4-3 (2) Parameter configuration**

## 4. Operation Panel (Keypad)

(Continued from previous page)

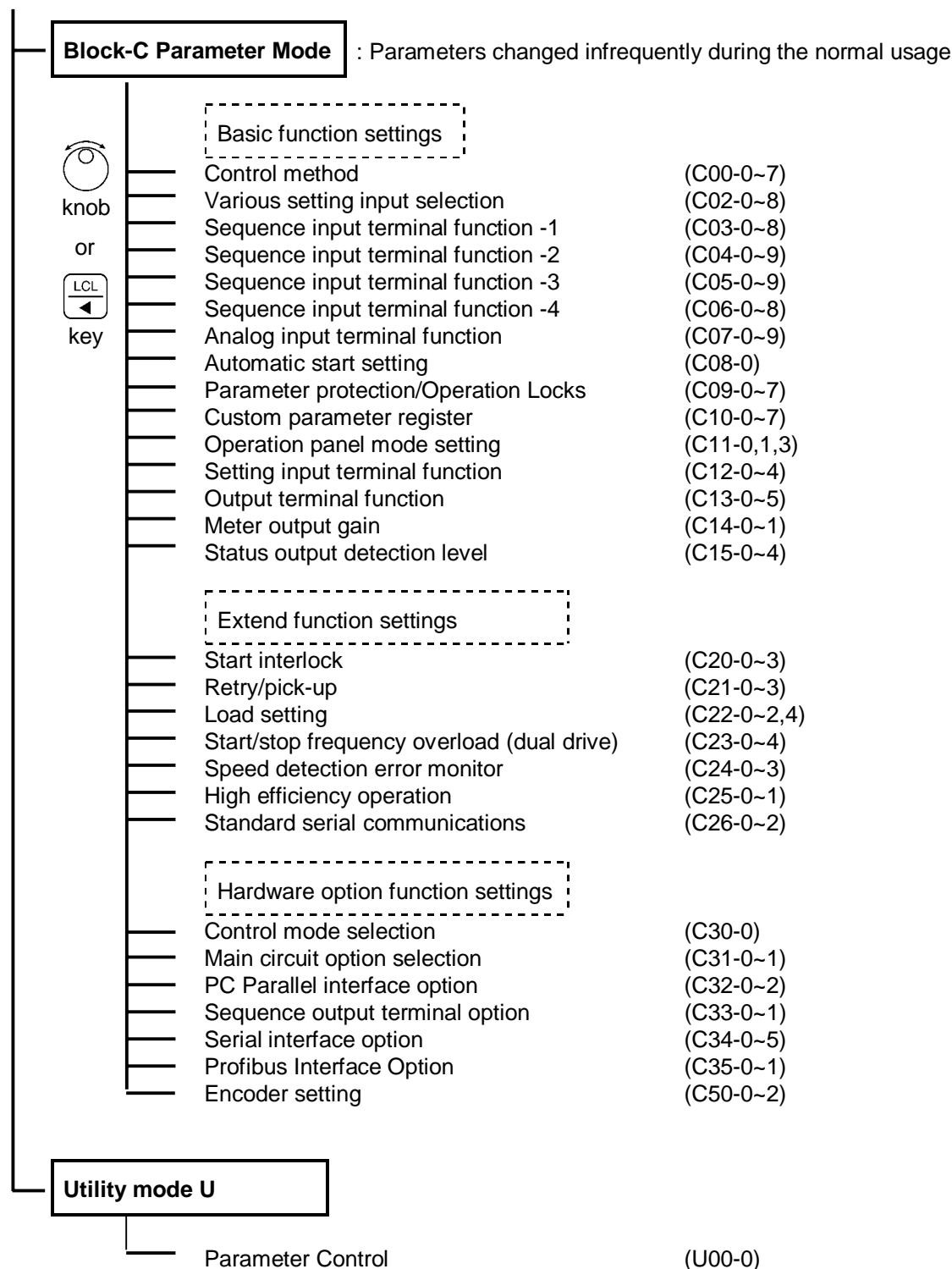

**(Note)** At the default setting, only the basic functions are displayed. The extended function, software option function, hardware option function parameters are skipped. Thus, to change these parameters, change parameter A05-0 to 3 (parameter B, C block skip setting), so that the target parameters are displayed.

**Fig. 4-3 (3) Parameter configuration**

4-2-3 PM Motor control mode

The configuration of the parameters is shown in Fig. 4-4.

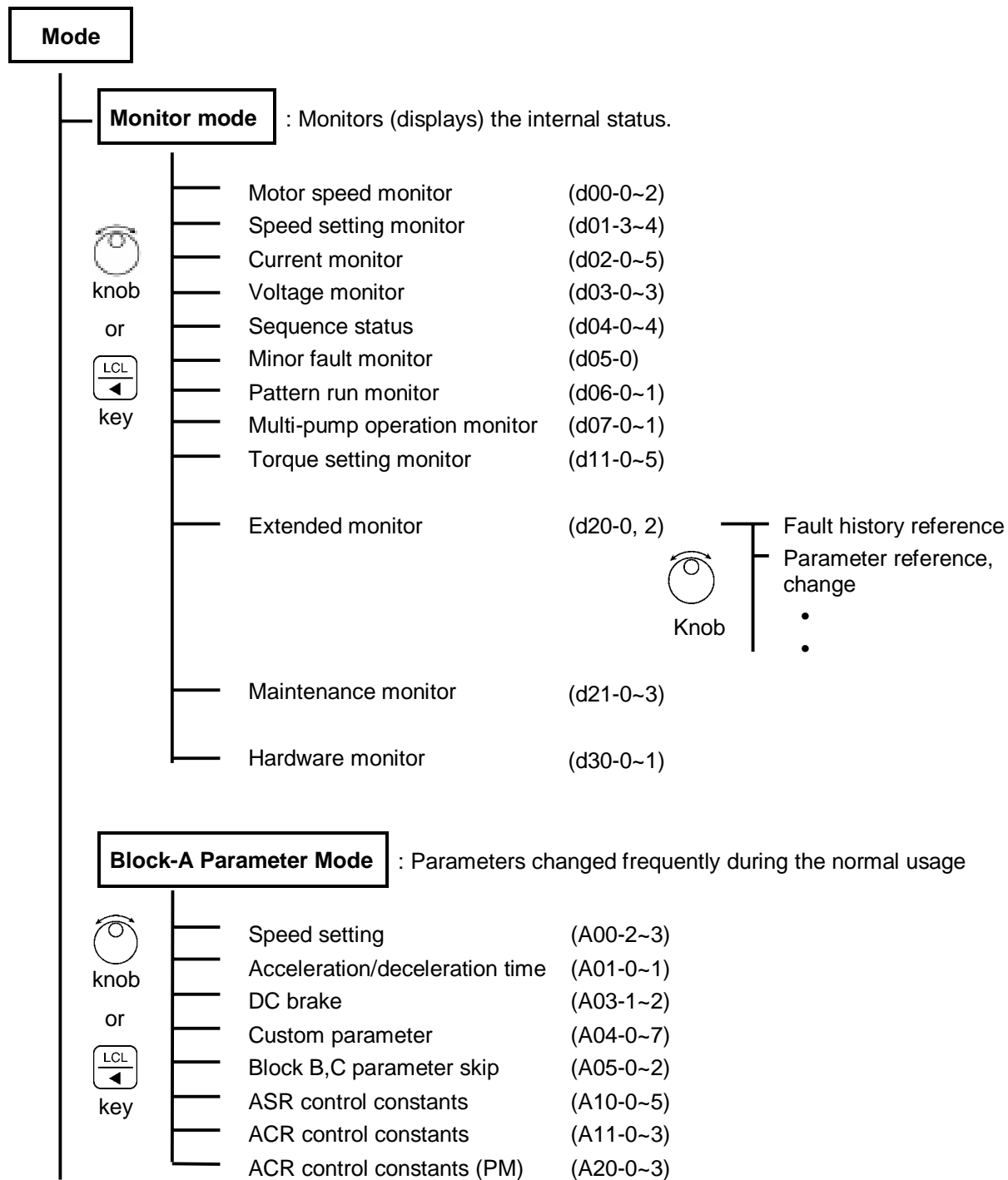

(Continued on next page)

Fig. 4-4 (1) Parameter configuration

## 4. Operation Panel (Keypad)

(Continued from previous page)

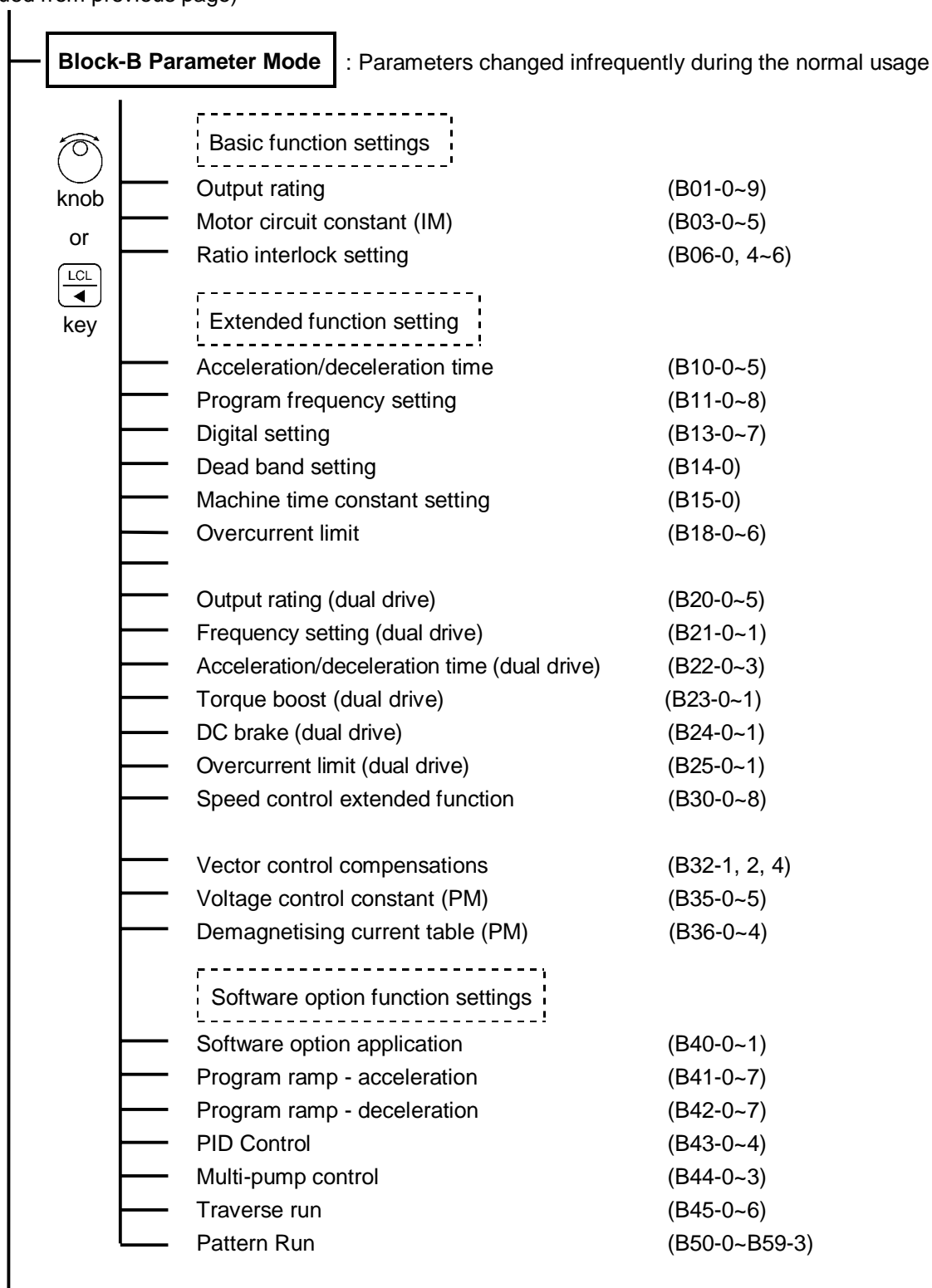

(Continued on next page)

**Fig. 4-4 (2) Parameter configuration**

## 4. Operation Panel (Keypad)

(Continued from previous page)

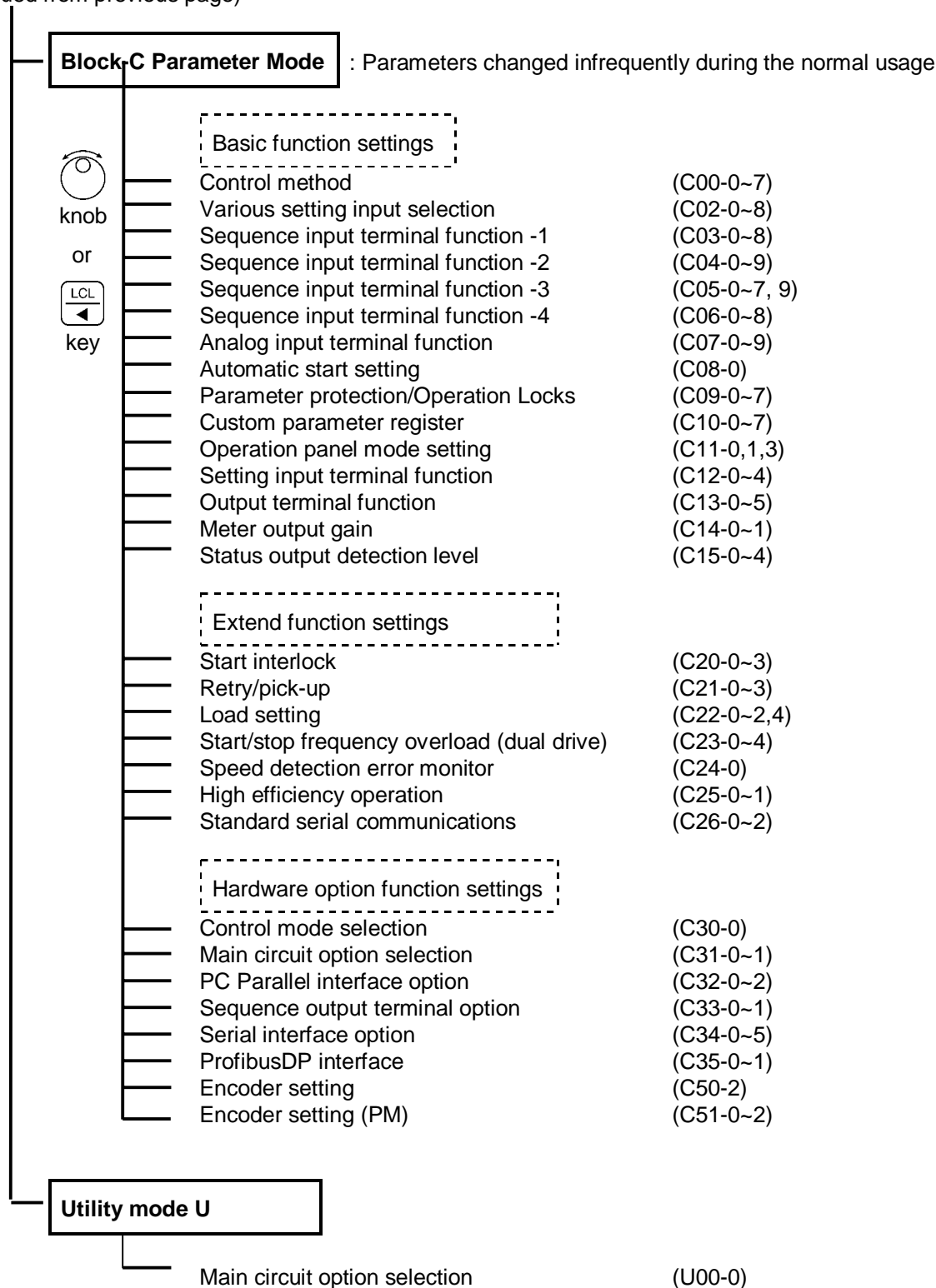

**(Note)** At the default setting, only the basic functions are displayed. The extended function, software option function, hardware option function parameters are skipped. Thus, to change these parameters, change parameter A05-0 to 3 (parameter B, C block skip setting), so that the target parameters are displayed.

**Fig. 4-4 (3) Parameter configuration**

### 4-3 Changing modes (block parameters)

There are five modes of display on the operation panel. The mode (or block) displayed will change each time when the  key is pressed.

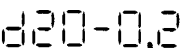
The monitor mode parameters ,  are the entries into the Extended Monitor Mode.

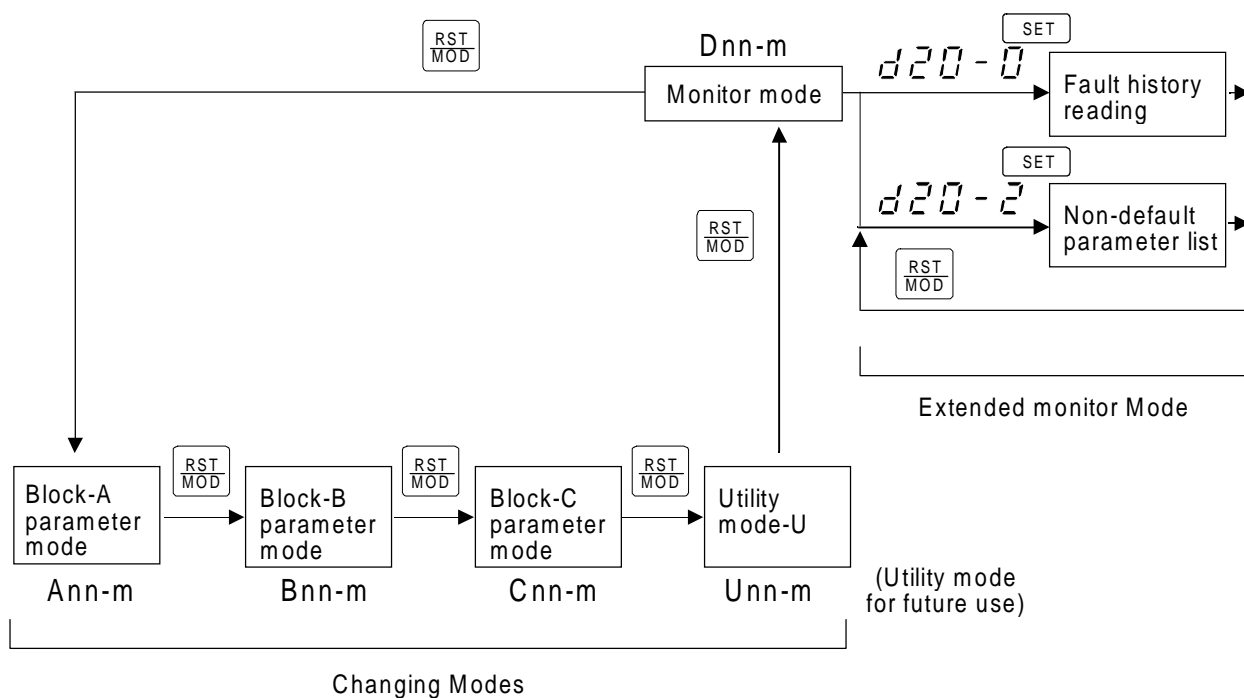
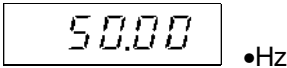

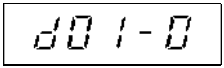

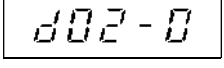

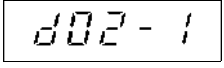
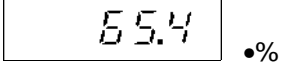

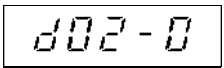

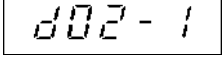

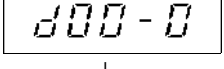
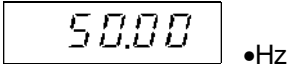



Fig. 4-4 Parameter mode changeover

4-4 Reading parameters in monitor mode

- 1) Refer to section 6.1 for the Parameters that can be read in Monitor Mode. Note this is for the case of V/f control (default setting C30-0=1).
- 2) The following is an example for reading the output current as a percentage and then showing the output frequency as Hz.

Keys	Display	Explanation
(1)		d00-0 : Output frequency
(2) 		Parameter block changes to d01 block.
(3) 		Parameter block changes to d02 block.
(4) 		Parameter number increases.
(5)		After one second, the display will show the output current as a percentage.
(6) 		Parameter number decreases.
(7) 		Parameter block number decreases.
(8) 		Parameter block number decreases again.
(9)		After one second, the display will show the output frequency as Hz.

- 4) Press  to show the Parameter Number on the display while monitoring.
- 5) Press  repeatedly to return to d00-0 from (5) as shown in the right sequence.

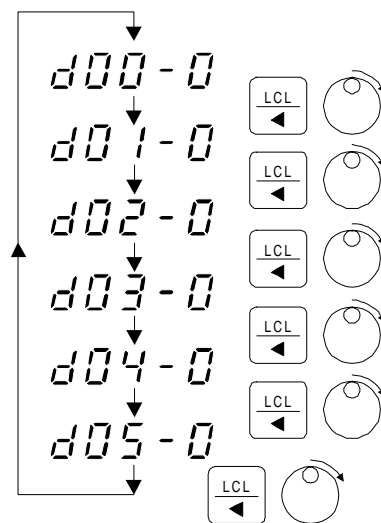











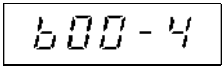

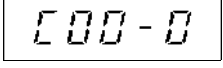

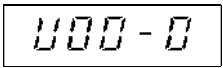

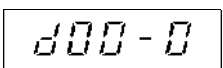

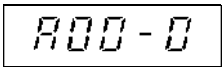

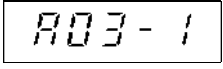

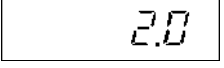
4-5 Reading and adjusting block-A & B & C parameters

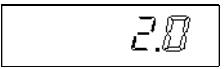
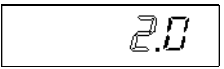

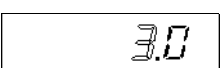
- 1) Refer to Sections 6-2 to 6-5, for the details of the Block-A, B and C parameters.
- 2) The below shown example is valid if the V/f control (constant torque) is enabled, (C30-0=1).

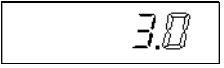
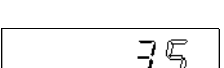

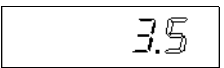
This example is for changing "maximum output frequency (Fmax) (P00 - 14)" in Block-B parameters, and then for changing "DC Breaking Time (P00 3 - 1)" in Block-A parameters

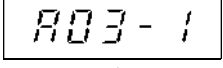
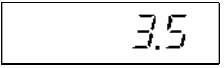
Keys	Display	Explanation
Change the Parameter: B00-4 (maximum output frequency (Fmax) from 50.0 (default value) to 60.0		
	50.00 •Hz	(In Monitor Mode)
(1)	P00-0	Changes to the Block-A Parameter setting Mode.
(2)	B00-0	Changes to the Block-B Parameter setting Mode.
(3)	B00-4	Increase the parameter No. from parameter B00-0 to B00-4.
	↓ ↑	
(4)	50.0	The display will alternate between Parameter Number B00-4 and the present setting value 50.0.
(Note 2)		Enable the value to be changed.
	50.0	The preset setting value will display.
(5)  2 times	50.0	Press  two times to move the flicker to the digit that is to be changed.
		(Note: Parameter B00-4 cannot be changed while the inverter is running.)
(6)	60.0	Change the flicker digit from 5 to 6.
		Fix the data.
(7)	B00-4	The change of Parameter B00-4 to 60.0 will be completed.
	↓ ↑	
	60.0	The display will alternate between the Parameter Number B00-4 and the present value. (Parameter Number Changing Mode.)

#### 4. Operation Panel (Keypad)











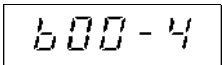

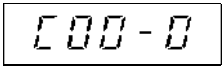

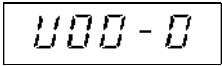

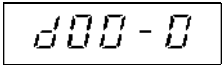
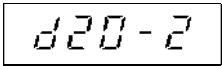

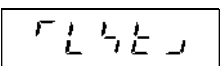

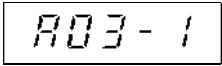

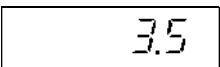
Keys	Display	Explanation
Change the parameter A03-1 (DC Breaking Time) from 2.0 (default value) to 3.5.		
(8) 		(In Block-B Parameter Setting Mode)
(9) 		Changes to the Block-C Parameter Setting Mode.
(10) 		Changes to the Utility Mode. (For future use)
(11) 		Changes to the Monitor Mode.
(12)  3 times <b>(Note 1)</b>		Changes to the Block-A Parameter Setting Mode.
(13) 	 ↓ ↑	Increase the Parameter Block Number from A00 to A03.
(14)  <b>(Note 2)</b>		The display will alternate between Parameter Number A03-1 and the present value 2.0.
(15) 	 	Enable the value to be changed. The preset setting value will display. Press  once to move the flicker to the digit that is to be changed.
(16) 		Change the flicker digit from 2 to 3.
(17)  2 times	 	Move the flickering digit to the digit to be changed Change the flicker digit from 0 to 5.
(18) 		Fix the data. Changing of parameter A03-1 to 3.5 will be completed.
(19) 	 ↓ ↑ 	The display will alternate between the Parameter Number A03-1 and the present value. (Parameter Number Changing Mode.)

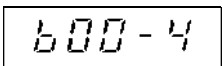
**(Note 1)** When the Block Number is changed by  , it will change to the next Block Number either up or down according to  ,  turned immediately before.

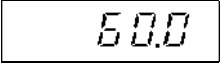
**(Note 2)** If  (RUN) displays while the parameter is being set in (4) and (14), the parameter is one of those that can only be changed while the inverter is stopped. In this case, stop the motor first, and then press  again.

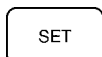
4-6 Reading the changed parameters (Non-default value parameter list)

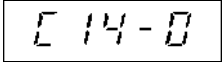

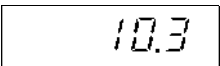
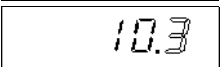





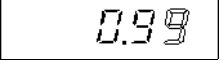

- 1) The Monitor Parameter d20-2 is the entry into the Block-A, B and C Non-Default Value Parameter Listing Mode.
- 2) In this Non-Default Value Parameter Listing Mode, the display will show the Block-A, B and C Parameters that have different values from their default values. These Parameter values can also be read and changed in this mode.
- 3) The below shown example is valid if the V/f control (constant torque) is enabled, (C30-0=1). This is an example for reading C14-0 (FM output gain) and changing its value.

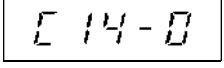
Keys	Display	Explanation
(1) 		(In Block-B Parameter Setting Mode)
(2) 		Change to Block-C Parameter Setting Mode.
(3) 		Change to the Utility Mode (For future use)
(4)  6 times	 	Change to the Monitor Mode.
(5) 		Increase the Parameter Block Number from d00 to d20. Increase the parameter number. Go to d20-2 (Non-Default Value Parameter List Mode Entry).
(6) 		After one second, [LST] will display. Enter the Non-Default Value Parameter List Mode.
(7) 	 	The display will alternate between the Parameter No. of the parameter (A03-1) changed first from the default value and the present setting value.
(8) 	   	The next Non-default Value Parameter Number will display. If  is turned, the next Non-Default Value Parameter Number will increment or decrement and display.
(9) 	    	The Parameter C14-0 (FM Output Gain) will display.  Select parameter C14-0. The setting value change state will be entered.

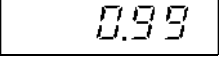
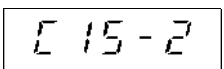
(Continued on next page)

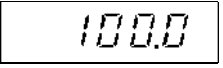
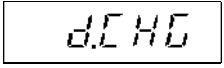
#### 4. Operation Panel (Keypad)

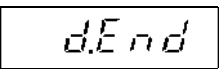
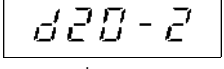
(Continued from previous page)

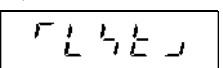
(10) 		Change the setting value from 1.03 to 0.99.
(11) 	 ↓ ↑	This completes changing of the setting value.
(12) 	  ↓ ↑	The next Non-Default Parameter Number will display.
(13) 	  ↓ ↑	The display will alternate between d. CHG and d.END to indicate the end of the Non-Default Value Parameter List.
(14) 	  ↓	If  is pressed after this, the Non-Default Value Parameter List will display again from the first.
		End the Non-Default Value Parameter List Mode. The Monitor Parameter Selection status will be entered. (After one second, [LST] will display.)





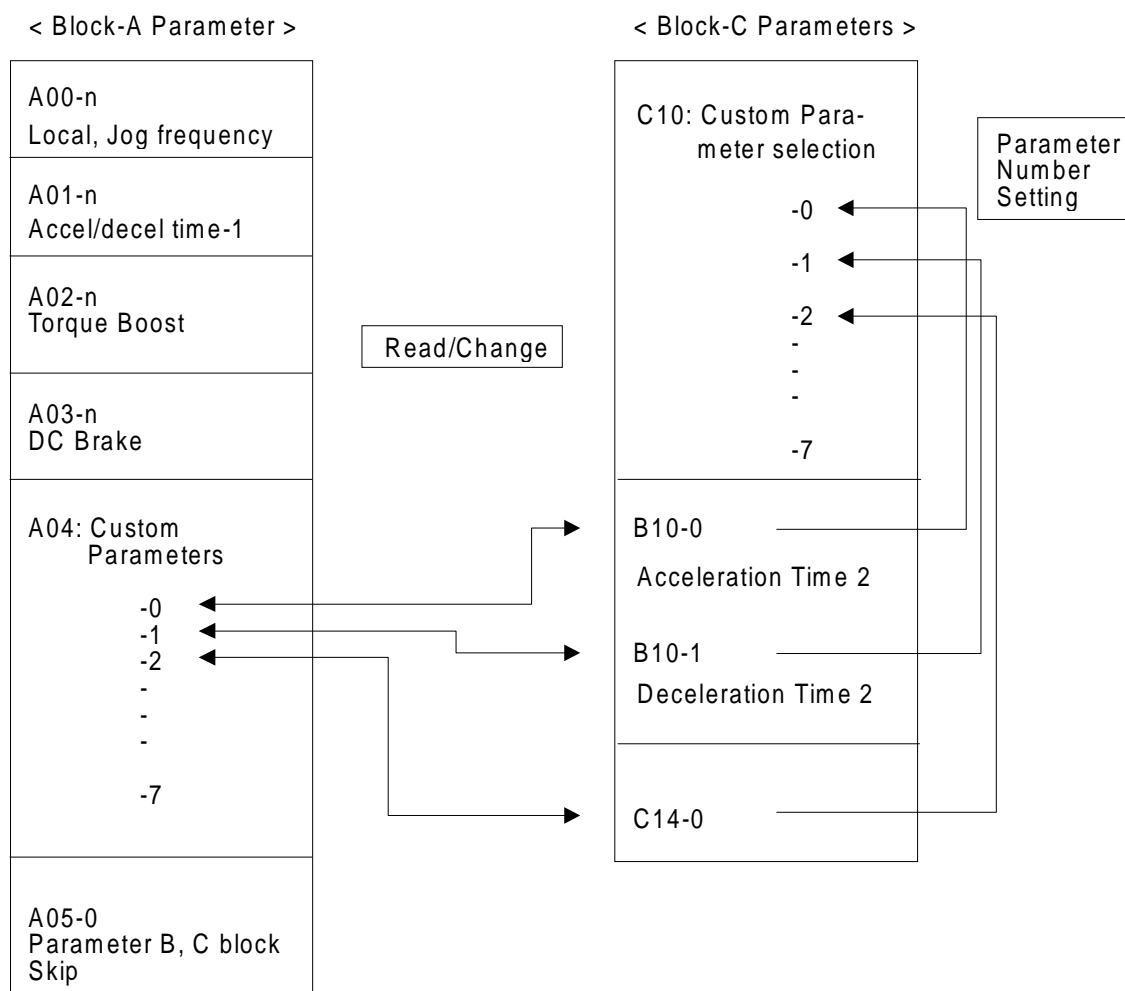







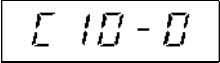
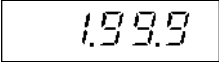
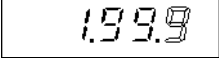
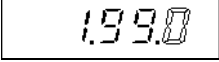
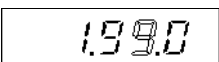
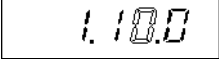
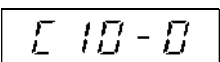
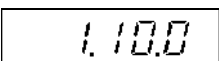

### 4-7 Customising block-B,C parameter

- 1) Block-B, C parameters can be assigned to any Block-A Parameter in the range of A04-0 to A04-7, and can be read and changed in the Block-A Parameter Setting Mode.
- 2) To use this function, set parameter No. to be displayed in A04-0 to 7 in parameter C10-0 to 7.
- 3) The below shown example is valid if the V/f control (constant torque) is enabled, (C30-0=1).



#### 4. Operation Panel (Keypad)

4) The following is an example for changing the value of a Custom Parameter.

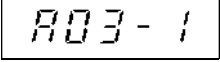
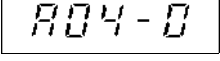
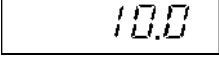
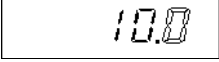
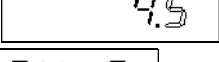
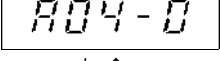
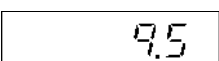





Keys	Display	Explanation
Register parameter B10-0 on Parameter C10-0 (Custom Setting).		
<p>(1)  </p> <p>(2) </p> <p>(3) </p> <p>(4) </p> <p>(5) </p> <p>(6) </p>	<p></p> <p>↓ ↑</p> <p></p> <p></p> <p></p> <p></p> <p></p> <p></p> <p>↓ ↑</p> <p></p>	<p>(Mode and Parameter Number Change to C10-0) The display shows Parameter C10-0. The value 1.99.9 indicates that no Parameter has been registered on Parameter C10-0.</p> <p>Select Parameter Number C10-0.</p> <p>Set the sub-number of B10-0 to "0".</p> <p>Each time  is pressed, the flickering digit will move to the digit to be changed.</p> <p>Turn the  knob key until the high-order digit reaches the block No. 10.</p> <p>Selection of the parameter No. C10-0 is completed.</p> <p><b>Note)</b> For parameter C, set as 2.xx.x.</p>
Change parameter B10-0 which has been assigned to A04-0.		
<p>(7)  3 times</p> <p>(8) </p> <p>(9) </p> <p>(10) </p> <p>(11) </p>	<p></p> <p></p> <p>↓ ↑</p> <p></p> <p></p> <p></p> <p></p> <p>↓ ↑</p> <p></p>	<p>Enter the Block-A Parameter Setting Mode. The Custom Parameter Number A04-0 will display.</p> <p>The display will alternate between Parameter number A04-0 and the value of Parameter number B10-0 (Acceleration time 2). Parameter Number A04-0 is the same value as that of Parameter Number B10-0.</p> <p>Parameter B10-0 can be changed now from parameter A04-0.</p> <p>Change the value as required.</p> <p>Store the new value.</p>

**Note 1)** If the Parameters C10-n values are either 1.99.9 or any other undefined values, Parameters A04-n will be skipped during Parameter scan.

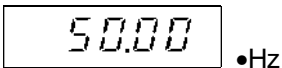
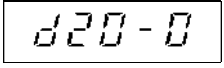
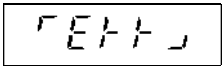

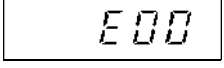
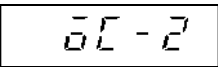

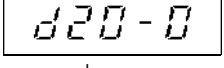
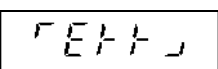

**Note 2)** If all the C10 Parameters are set at 1.99.9. all the A04 Parameter block will be skipped during Parameter scan.

4-8 Reading fault history

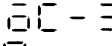
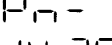
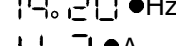
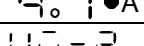
- 1) Parameter number d20-0 in the Monitor Mode is an entry into the Fault History Mode.
- 2) The following is an example in which the Fault History Mode is entered.

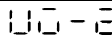
Keys	Display	Explanation
(1)  6 times	  ↓ 	(D00-0 will display in the Monitor Mode.)  Select Monitor Parameter D20-0.  The [ERR] symbol will display after one second.
(2) 	 ↓ ↑ 	Select and enter the Fault History Mode. The fault history number Emm and the fault code will display alternately.
(3)  or 	 ↓ 	Scan the contents of the fault buffer using the  key and  knob.  End the Fault History Mode and return to the Monitor Mode.

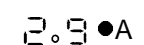
- 3) The Fault History Buffer is configured as shown below.

Change of display	Fault sequence	Fault History number	Display (Example)	Explanation
	Fault 1 (the latest)	E00		Latest Fault Code
		E01		Secondary Fault Code
		E02		Output frequency at the Fault
		E03		Output current at the Fault
	Fault 2	E10		No Secondary Fault
		E11	----	
		E12		
		E13		
	Fault 3	E20	----	Indicates that no Fault has been recorded.
		E21	----	
		E22	----	
		E23	----	
	Fault 4	E30	----	Indicates that no Fault has been recorded.
		E31	----	
		E32	----	
		E33	----	

- 4) Set parameter C09-6 to 1 to clear the Fault History Buffer.
- 5) Refer to the Appendix 3 for details

## Chapter 5 Control Input / Output

### 5-1 Input / Output Terminal Function

The terminal block and input/output functions related to control are shown in Tables 5-1.

**Table 5-1 Terminal block functions**

	Symbol	Name	Features
Sequence input	RY0, RY24	Relay input common	This is a common terminal for relay input signals specified below. Either sink or source logic control can be changed with internal jumper W1.
	PSI1~PSI5	Programmable input	These are programmable inputs, which can be assigned to remotely ON/OFF control any of the sequence input functions (C03 to C06).
	EMS	Emergency stop	If EMS is ON while the VAT2000 is stopped, all operational commands are inhibited. If it is ON during operation, the VAT2000 is led into a stopping sequence, either ramp down stop or coast-to-stop selectable. It is also possible to output this signal as a fault (FLT). (C00-4)
	RESET	Fault reset	This reset a faulty condition. With this signal, a fault status output (FLT LED, FAULT relay operation) is turned OFF and operation is allowed again.
	RUN	Forward run	This is a command for forward run. Either permanent or push-buttons commands for run/reverse control can be selected. Operating command from RUN terminal is allowed in the remote operation mode (LCL LED unlighted). (C00-0)
Analog input	FSV	Voltage/frequency setting	This is mainly used for frequency (or speed) setting input. The maximum frequency (speed) setting is available at a 10V input. This setting is enabled when VFS of the internal relay signal is ON. (C04-1, C07-0=2, C12-0=1)
	FSI	Current/frequency setting	This is mainly used for frequency (or speed) setting input. A maximum frequency (speed) setting is available at a 20mA input. This setting is valid when IFS of the internal relay signal is ON. (C04-2, C07-1=3, C12-1=1)
	AUX	Auxiliary input	This is mainly used for frequency (or speed) setting input. A maximum frequency (speed) setting is available at a ±10V input. This setting is valid when AUX of the internal relay signal is ON. (C04-3, C07-2=4, C12-2=1)
	COM	Analog input common	This is a common terminal for FSV, FSI and AUX signals.
Analog output	FM	Frequency meter	This is a voltage output signal for metering purpose. As default, a 10V output is available at the maximum frequency. This output voltage can be adjusted from 0.2 to 2.0 times 10V. (Max. output is, however, approximately 11 volts.) Internal analog signals other than output frequency can also be output. (C13-0, C14-0)
	AM	Ammeter	This is a voltage output signal for metering purpose. As default, an output of 5V is available for the rated current. This output voltage adjustment of 0.2 to 2.0 times of 5V is also available. Internal analog signals other than those of current can also be output. (C13-1, C14-1)
	COM	Analog output common	This is a common terminal for the analog outputs.
	P10	FSV source	This is a 10V source used when a frequency (speed) setter is connected to the FSV input circuit. The frequency (speed) setter to be used should be a variable resistor of 2W and 2kΩ.
Sequence output	RC, RA	RUN	This is a contact to be ON during operation or DC braking. Other internal ON/OFF signals can be output with the C13-2 setting.
	FC, FA, FB	Fault	These contacts switch when a fault occurs (then the FLT LED lights). When a fault occurs, NO contact FA-FC switches to ON and the NC contact FB-FC switches to OFF.
	PSO1	READY (1)	This is the open collector output that turns ON at READY status. Other internal signals can be output with the C13-3 setting.
	PSO2	Current detection	This is the open collector output that turns ON when the output current reaches the setting. (C15-1) Other internal signals can be output with the C13-4 setting.
	PSO3	Frequency (speed) attainment	This is the open collector output that turns ON when the output frequency (speed) reaches the setting. (C15-0) Other internal signals can be output with the C13-5 setting.
	PSOE	Open collector output common	These are the common terminals for the PSO1, 2 and 3 signals.

5-2 Control Input / Output Circuit

Examples of the control input/output circuit wiring are shown in table 5-2. The precautions must be observed during wiring.

Table 5-2 Control input/output circuit

Function	Example of wirings	Precautions																	
Sequence input		<ol style="list-style-type: none"> <li>1. Wiring must not be longer than 50m.</li> <li>2. The allowable leakage current is 0.5mA.</li> <li>3. Use an adequate current contact.</li> <li>4. Do not link to the analog input/output.</li> <li>5. The sink/source logic can be changed by jumper W1. (1: Sink 2: Source)</li> </ol>																	
Analog input and P10 output		<ol style="list-style-type: none"> <li>1. Use 2kΩ (2.5kΩ)/2W rating setter for the external variable resistor.</li> <li>2. The maximum input rating of FSV is -0.0 to +10.5V.</li> <li>3. Use a shielded wire shorter than 30m for the wiring.</li> <li>4. For shield connections, connect to COM terminal on the VAT2000 side.</li> <li>5. The maximum input rating for FSI is 0 to +21mA or 0 to +5.25V.</li> <li>6. Do not link to the digital input.</li> </ol>																	
Analog output		<ol style="list-style-type: none"> <li>1. Use a 10V full scale meter (impedance: 10kΩ or higher).</li> <li>2. The maximum output current is 1mA.</li> <li>3. Use a shielded wire shorter than 30m for the wiring.</li> <li>4. For shield connections, connect to COM terminal on the VAT2000 side.</li> </ol>																	
Sequence output (Relay output)		<ol style="list-style-type: none"> <li>1. Use within the rated range shown below. To comply with UL, use at 30VAC/DC or less.</li> </ol> <table border="1" data-bbox="949 1451 1364 1736"> <thead> <tr> <th></th> <th>RUN</th> <th>FLT</th> </tr> </thead> <tbody> <tr> <td rowspan="2">Rated capacity (resistive load)</td> <td>250VAC 1A</td> <td>250VAC 0.4A</td> </tr> <tr> <td>30VDC 1A</td> <td>30VDC 1A</td> </tr> <tr> <td>Max. voltage</td> <td>250VAC</td> <td>250VAC 220VDC</td> </tr> <tr> <td>Max. current</td> <td>1A</td> <td>1A</td> </tr> <tr> <td>Switching capacity</td> <td>100VA 100W</td> <td>50VA 60W</td> </tr> </tbody> </table>		RUN	FLT	Rated capacity (resistive load)	250VAC 1A	250VAC 0.4A	30VDC 1A	30VDC 1A	Max. voltage	250VAC	250VAC 220VDC	Max. current	1A	1A	Switching capacity	100VA 100W	50VA 60W
	RUN	FLT																	
Rated capacity (resistive load)	250VAC 1A	250VAC 0.4A																	
	30VDC 1A	30VDC 1A																	
Max. voltage	250VAC	250VAC 220VDC																	
Max. current	1A	1A																	
Switching capacity	100VA 100W	50VA 60W																	
Sequence output (Open collector output)		<ol style="list-style-type: none"> <li>1. To drive an inductive load, such as a coil, insert the fly wheel diode shown in the drawing.</li> <li>2. Keep the wiring length to 50m or less.</li> <li>3. Use within the following rating range. 30VDC, 50mA</li> </ol>																	

### 5-3 Programmable sequence input function (PSI)

The VAT2000 can basically be operated in three modes, from drive's terminal block, from the operation panel and from the serial communication ports. Input signals like RESET or EMS operate in all cases, but some others can be enabled or disabled for operation by the changeover switches (J1, J2) or programmable sequence input function COP. (Check fig 5-2)

The digital standard input functions in the basic PCB terminal block of VAT2000, includes three fixed function inputs which are forward run, reset and emergency stop. There are also five programmable digital inputs, which can be randomly assigned with functions selected from Table 5-3. Four additional programmable inputs are available using the relay interface option card U2KV23RY0.

The standard programmable input terminals are PSI1 to PSI5. When extended, the terminals are PSI1 to PSI9. The default settings are as shown below.

**Default settings**

<b>Symbol</b>	<b>Setting</b>
PSI1	Reverse run
PSI2	Forward jogging
PSI3	Reverse jogging
PSI4	None
PSI5	None

The fixed input signal functions are given in Table 5-1, and the programmable input signal functions are given in Table 5-3.

The general block diagram for vector control operation is shown in Fig.5-1..

## 5. Control Input / Output

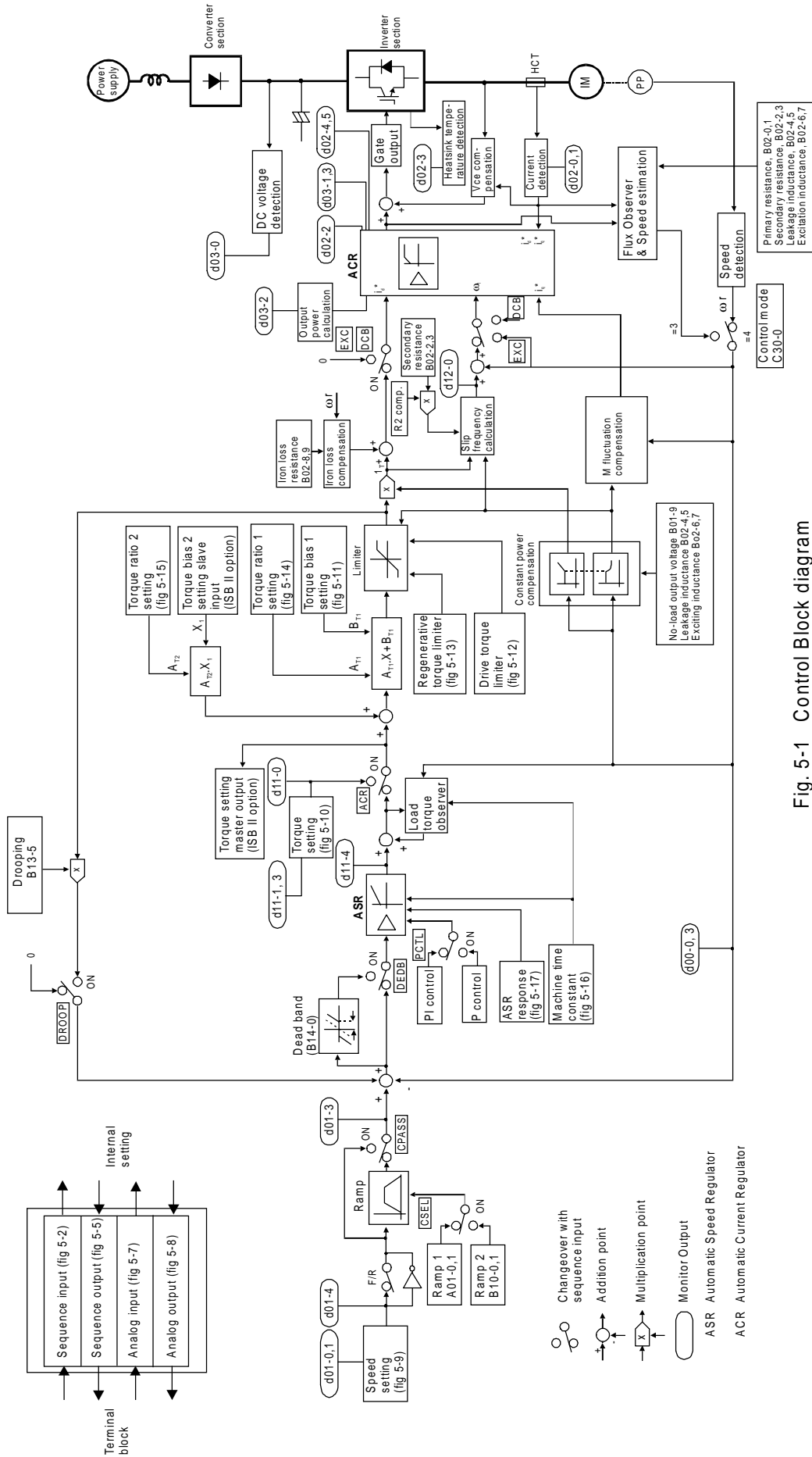

Fig. 5-1 Control Block diagram

## 5. Control Input / Output

**Table 5-3 Programmable sequence input functions (1)**

Connection of PS11 to PS19 is possible. Note that PS16 to PS19 are options.  
The connection is done with data Nos.: C03 to C06

Symbol	Name	Function									
R RUN	Reverse run	This is a command for reverse run. This command allows run/reverse switchover when C00-0=2.									
F JOG	Forward jogging	These are jogging commands. If this signal is ON while RUN is OFF, the output frequency or motor speed is fixed according settings in (A00-1 or 3). For stoppage, either ramp down stop or coast-stop is available.									
R JOG	Reverse jogging										
HOLD	Hold	This is a stop signal used when Forward or reverse operation to RUN/REV is commanded by push-buttons (self-hold mode). The VAT2000 stops with this signal turned off.									
BRAKE	DC brake	DC brake can be operated with this signal. During the PM motor control mode, DC excitation is provided by this function.									
COP	Serial transmission selection	<p>When this function is ON, settings or sequence control commands are received from the serial communications port. Some of these however can be controlled from the drive's terminal block with parameter C00-6</p> <table border="1" style="margin-left: auto; margin-right: auto;"> <thead> <tr> <th></th> <th>C00-6</th> <th>Input Point</th> </tr> </thead> <tbody> <tr> <td rowspan="2" style="text-align: center;">ON</td> <td style="text-align: center;">1</td> <td>control from terminal block</td> </tr> <tr> <td style="text-align: center;">2</td> <td>Control from serial transmission</td> </tr> </tbody> </table> <p>Check drawings on fig 5-2</p>			C00-6	Input Point	ON	1	control from terminal block	2	Control from serial transmission
	C00-6	Input Point									
ON	1	control from terminal block									
	2	Control from serial transmission									
C SEL	Ramp selection	<p>Accel./decel. standard and secondary ramps switchover. Accel./decel. time 1 (A01-0, 1) is available when CSEL is OFF. Accel./decel. time 2 (B10-0, 1) is available when CSEL is ON</p>									
I PASS	Ratio interlock bypass	Ratio interlock operation is bypassed. This is the ratio between frequency setting input and frequency setting output									
CPASS	Ramp bypass	The ramp function is by-passed									
VFS	Speed setting 1	The frequency (speed) setting is carried out with the input selected with C07-0.	<p>When inputs are entered simultaneously, setting is selected in accordance with following preference order. JOG&gt;CFS&gt;PROG&gt;AUX&gt;IFS&gt;VFS</p>								
IFS	Speed setting 2	The frequency (speed) setting is carried out with the input selected with C07-1.									
AUX	Speed setting 3	The frequency (speed) setting is carried out with the input selected with C07-2.									
PROG	Program function enable	Used for multiple setting. Selection of up to 8 fixed speeds (PROG0~PROG7)									
CFS	Serial communication setting select	Allows speed (or torque) setting from serial communication port.									
S0 to S3 SE	Program setting selection	When PROG is ON, the 8 program frequency (speed) (B11-0~7), are selected by S0-S3, SE . BCD or direct selection allowed with B11-8									
FUP	Frequency (speed) increase	The currently frequency (speed) setting in (A00-0, A00-2) or program frequency setting 0 to 7 (B11-0~7) is increased or decreased by FUP or FDW functions									
FDW	Frequency (speed) decrease	The frequency output (or speed) is increased or decreased according valid acceleration or deceleration ramp time.									

## 5. Control Input / Output

**Table 5-3 Programmable sequence input functions (2)**

Symbol	Name	Function
BUP	Ratio interlock bias increase	When IVLM is ON, the ratio interlock function increases or decreases the frequency setting output by BUP or BDW functions. The motor increases or decreases its speed according currently valid ramp rate. When IVLM turns OFF, the bias increase/decrease value will be cleared to zero, and BUP/BDW operation will be disabled.
BDW	Ratio interlock bias decrease	
IVLM	Bias BUP/BDW selection	
AUXDV	Auxiliary drive selection	The dual drive settings are validated with this signal.
PICK	Pick-up	While this signal is ON, pick-up (flying start) operation is effected as soon as RUN or R RUN is ON.
EXC	Pre-excitation	Pre-excitation is applied to the motor. Pre-excitation consist to establishing only the flux in the motor without generating toque. This is useful when high torque is required immediately at the start time.
ACR	ACR	ACR operation is selected.
PCTL	P Control	ASR control is changed from the PI control to the P control.
LIM1	Drive torque limit changeover	When this function is ON, is possible to control the drive torque limit, by an analog input signal or by a serial transmission signal.
LIM2	Regenerative torque limit changeover	When this function is ON, is possible to control the regenerative torque limit, by an analog input signal or by a serial transmission signal.
MCH	Machine time constant changeover	This function allows ASR gain changeover from two machine time constant values. machine time constant 1 (A10-1) is available if MCH is OFF. Machine time constant 2 (B15-0) is available if MCH is ON.
RF0	0 setting	The speed setting is changed to 0 rpm.
DROOP	Drooping changeover	Drooping function is validated. (B13-5)
DEDB	Dead band setting	The dead band setting of ASR is validated. (B14-0)
TRQB1	Torque bias setting 1	The torque bias input 1 is valid.
TRQB2	Torque bias setting 2	The torque bias input 2 is valid.
PIDEN	PID control selection	The PID control is validated. Useful function for slow processes control

**(Note)** ASR: Automatic Speed Regulator  
ACR: Automatic Current Regulator

**5-4 Programmable sequence output function (PSO)**

As standard, there are five digital outputs in the VAT2000 (1NO/NC dry contact, one NO dry contact and three open collector transistor outputs).

The 1NO/NC dry contact output is fixed to fault output, but the other four channels are programmable and can be set arbitrarily to any of the output signals given in Table 5-4.

Two additional dry relay outputs are possible by Optional PCB interfaces (type: U2KV23RY0 or U2KV23PI0).

The programmable output provided in VAT2000 as standard are RA-RC, PSO1, PSO2 and PSO3.

**Default values**

Terminal symbol	Setting
FA-FB-FC	Fault: Fixed
RA-RC	Run
PSO1-PSOE	Ready (1)
PSO2-PSOE	Current detection
PSO3-PSOE	Frequency (speed) attainment

The functions of the programmable output signals are given in Table 5-4.

**Table 5-4 Programmable sequence output functions**

Symbol	Name	Function						
RUN	Run	This turns ON during running, jogging or DC braking. Turning ON or OFF during pre-excitation can be selected. <table border="1" style="margin-left: 40px;"> <thead> <tr> <th>C00-7</th> <th>RUN output</th> </tr> </thead> <tbody> <tr> <td>1</td> <td>ON during pre-excitation</td> </tr> <tr> <td>2</td> <td>OFF during pre-excitation</td> </tr> </tbody> </table>	C00-7	RUN output	1	ON during pre-excitation	2	OFF during pre-excitation
C00-7	RUN output							
1	ON during pre-excitation							
2	OFF during pre-excitation							
FLT	Fault	This turns ON during a fault.						
MC	Charge completed	This turns ON when the DC main circuit voltage reaches full voltage after power ON						
RDY1	Ready (1)	This turns ON when there is no fault, EMS is not activated, and pre-charging is done.						
RDY2	Ready (2)	This turns ON when there is no fault, EMS is activated and pre-charging is completed.						
LCL	Local	This turns ON when the operation mode is local (operation from the operation panel).						
REV	Reverse run	This turns ON while the motor is running in reverse direction.						
IDET	Current detection	This turns ON when the output current reaches the detection level (C15-1) or higher.						
ATN	Frequency (speed) attainment	This turns ON when the output frequency (speed) reaches the set frequency (speed). The detection reach width is set with C15-0.						
SPD1	Speed detection (1)	This turns ON when the output frequency (speed) absolute value reaches a speed higher than the speed set with the detection level (C15-2).						
SPD2	Speed detection (2)	This turns ON when the absolute motor speed reaches a speed higher than that set in the detection level (C15-3).						
COP	Transmission selec.	This turns ON when serial transmission operation is selected.						
EC0-EC3	Fault code 0 to F	This outputs the fault messages with a 4-bit binary code. EC0 is the low-significant bit, and EC3 is the most significant bit. Refer to Appendix 3 for details on the fault codes.						
ACC	Acceleration	This turns ON during acceleration.						
DCC	Deceleration	This turns ON during deceleration.						
AUXDV	Auxiliary drive selection	This turns ON when the auxiliary drive parameter setting is validated by the sequence input AUXDV.						
ALM	Minor fault	This turns ON during a minor fault.						
FAN	Fan control	This turns ON during running, jogging, pre-excitation and DC braking. A three minute off delay is provided. This is used for external fan control.						
ASW	Automatic start wait	When the automatic start function is enabled by C08-0, ASW will turn ON while waiting for automatic start.						
ZSP	Zero speed	This turns ON when the output frequency (speed) absolute value is below the level set with zero speed (C15-4).						
LLMT	PID lower limit	These turns ON when the feedback value exceeds the limit value (<B43-3) or (>B43-4) during PID operation						
ULMT	PID upper limit							

**(Note)** "ON" indicates that the contact is closed.

5-5 Sequence input logic

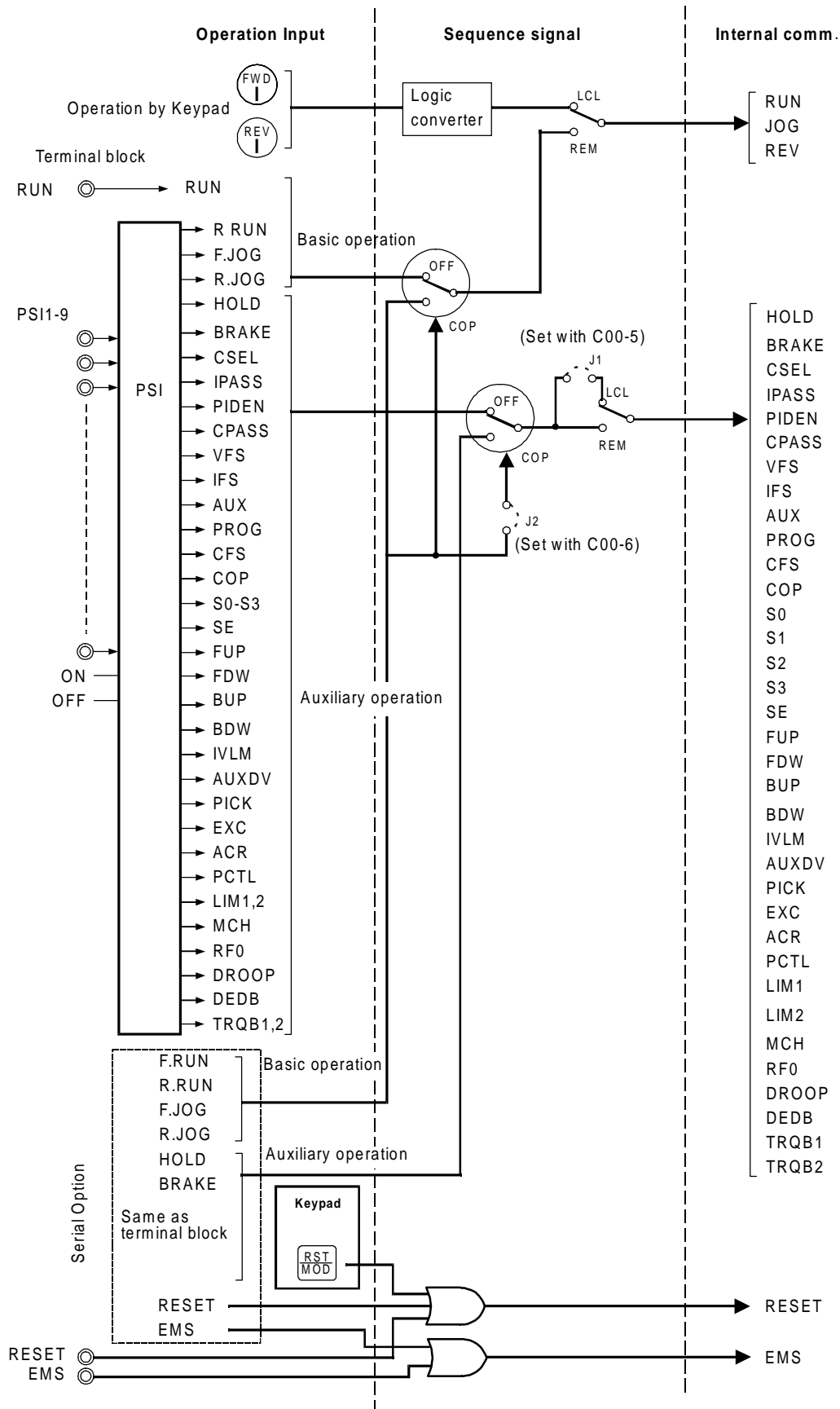

Fig. 5-2 Sequence input logic

### 5-6 Changing of terminal functions

The programmable input terminals (PSI1 to PSI9) can be arbitrarily assigned to control internal commands. On the other hand the state of some internal functions can be connected to the programmable output terminals (RA-RC and PSO1 to PSO5) to lead out the ON/OFF signals.

#### 5-6-1 Sequence input terminal assignment and monitoring

The functions that can be assigned to the terminal block are shown in Fig. 5-3. Each internal function can be fixed to ON (set value to 16) or OFF (set value to 0). If the function is set for example at "1", then input PSI1 can switch that function ON/OFF. Fig 5-3 shows the default assignment, where R.RUN has been assigned to PSI1 input (C03-0=1).

Fig. 5-4 shows monitoring display allowed by parameter D04-0, 1, or 2. Thus the ON state of each internal signal can be known through the operation panel display.

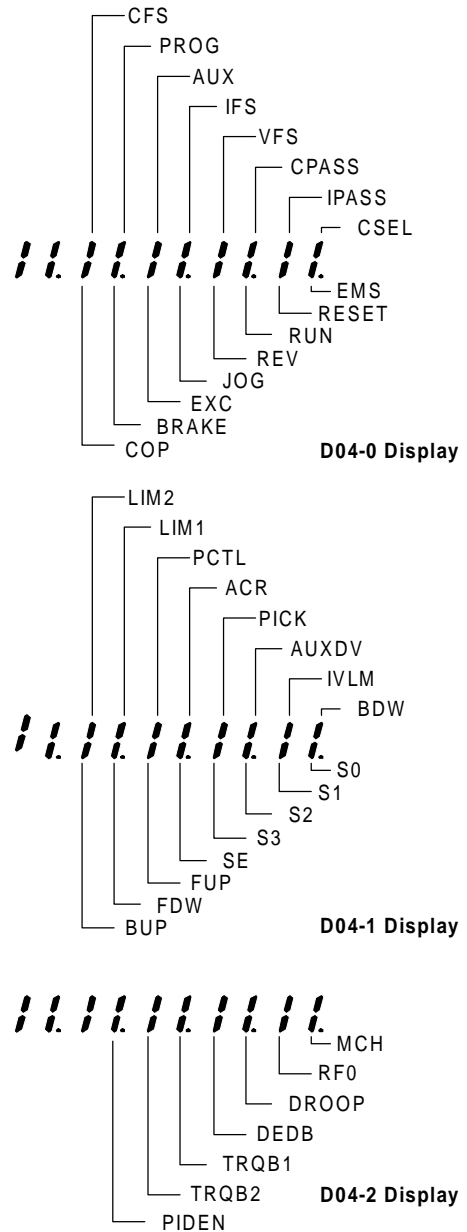
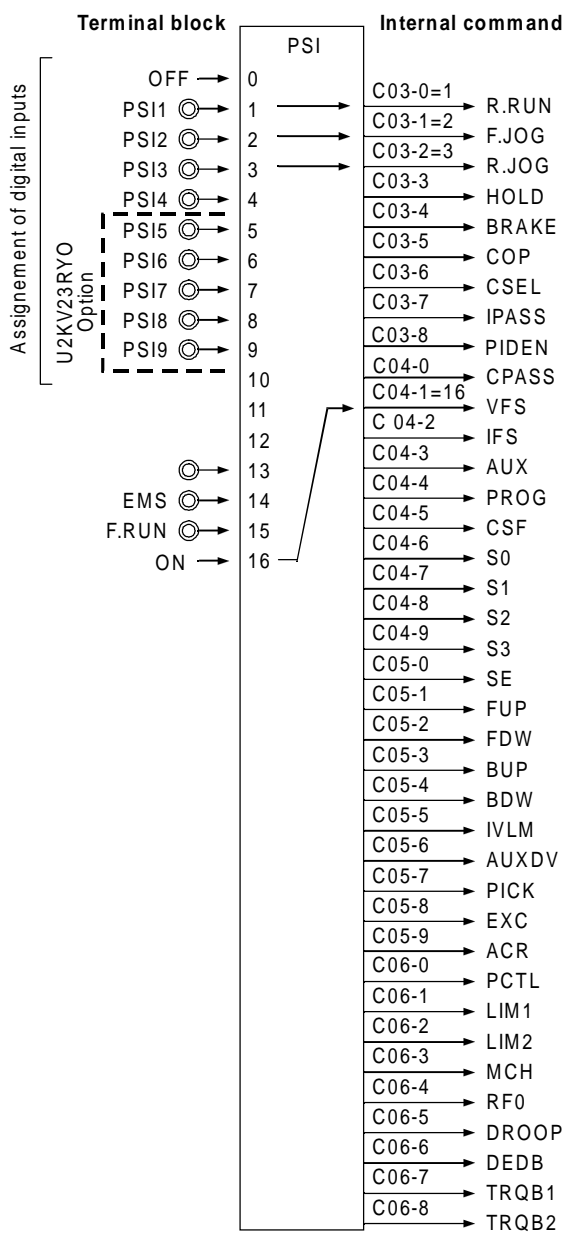

Fig. 5-3 Assignment of sequence input

Fig. 5-4 Sequence input monitor

5-6-2 Sequence output terminal assignment and monitoring

The ON/OFF of the internal signals can be output to the RA-RC and PSO1 to 3 (common: PSOE) terminals as shown in Fig. 5-5 by the parameter Nos. C13-2 to 5 and C33. The ON/OFF of each signal can be monitored as shown in Fig. 5-6. This monitoring is executed with D04-3, 4.

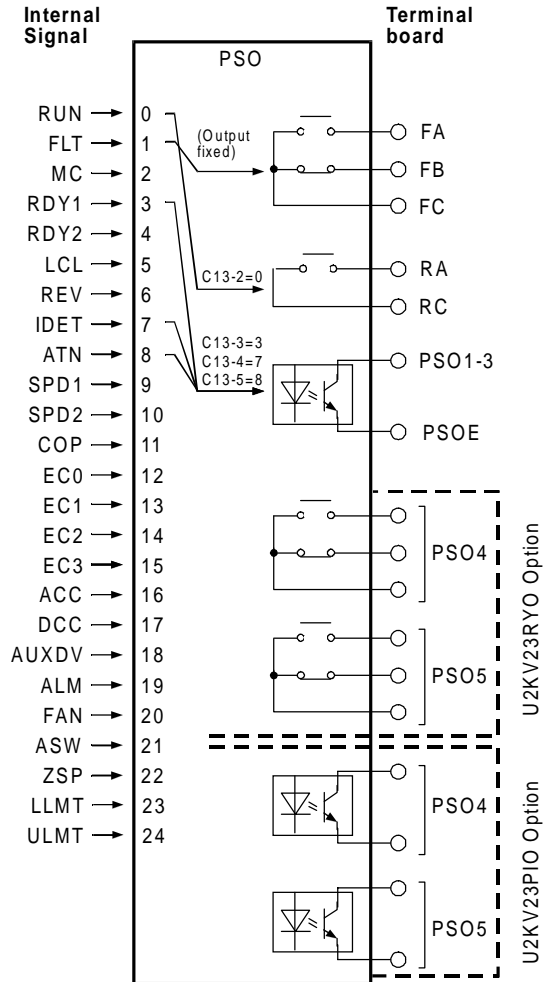

Fig. 5-5 Assignment of sequence output

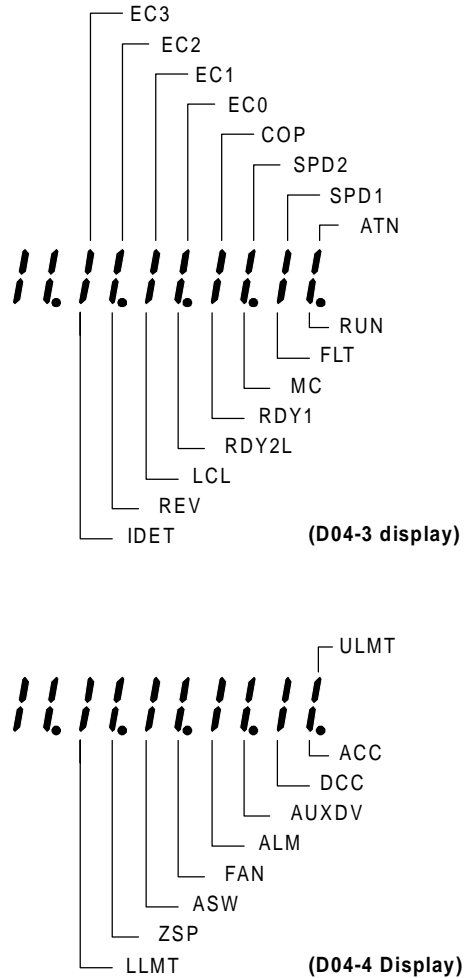

Fig. 5-6 Sequence output monitor

5-7 Programmable analog input function (PAI)

5-7-1 Types of analog inputs

The VAT2000 includes as standard three analog inputs to terminals FSV, FSI and AUX. Each analog input can be connected to the internal setting signals shown in Table 5-5 by using the programmable input function.

By connecting an analog interface option (type: U2KV23AD0), the programmable input terminals can be expanded to up to six channels.

Table 5-5 Types of internal setting signals assigned to analog input

Signal name	Setting range (Note 1)			Function
	FSV	FSI	AUX	
	0-10V 0-5V 1-5V	4-20mA 0-20mA	0 - ±10V 0 - ±5V 1-5V	
Speed setting 1 Speed setting 2 Speed setting 3	0~100%	-100~100% 0~100%	This is the speed setting. The (+) polarity is forward run, and the (-) polarity is the reverse run settings. When the speed setting by analog signal is enabled, then setting 1,2,3 may be selected with the sequence input functions (VFS, IFS,AUX).	
Ratio interlock bias setting	0~100%	-100~100% 0~100%	This allows bias setting (C) to ratio interlock function using an analog input.	
Traverse center frequency setting	0~100%	0~10V 0~5V 0~100% <b>(Note 2)</b> 0~100%	This allows center frequency setting for traverse operation, using an analog input. The positive polarity is the forward run, and the negative polarity the reverse run.	
PID feedback	0~100%	0~10V 0~5V 0~100% <b>(Note 2)</b> 0~100%	This is used for feedback signal to the PID function, using external sensor. Do not use the PID for speed control Do not use the programmable analog output (FM, AM) as PID's feedback signal.	
Torque setting	0~300%	-300~300% 0~100%	This is the analog setting for torque control. The (+) polarity is the forward direction torque, and the (-) polarity is the reverse direction torque. The torque setting can be limited by using the torque limiter function (A11-2, 3).	
Drive torque limit reduction setting	0~100%	0~10V 0~5V 0~100% <b>(Note 2)</b> 0~100%	The drive torque limit (A10-3 or A11-2) may be reduced in percentage using an analog input. For example using a signal of 0V to +10V the limit torque is reduced from 0 to 100% This function is enabled when LIM1, is ON.	
Regenerative torque limit reduction setting	0~100%	0~10V 0~5V 0~100% <b>(Note 2)</b> 0~100%	The regenerative torque limit (A10-4 or A11-3) may be reduced in percentage using an analog input. This function is enabled when LIM2 is ON.	
Torque bias 1 setting	0~300%	-300~300% 0~300% 0~300%	A torque bias signal during either speed or torque control is allowed using an analog input. This is enabled when the torque bias function TRQB1, is ON..	

**(Note 1)** FSV, FSI, AUX inputs and modes are selected with C12-0 to 2.

**(Note 2)** AUX: The setting is limited to 0% during the -10 to 0V and -5 to 0V input.

5-7-2 Setting the analog input

The analog inputs can be randomly assigned to the internal setting signals given in Table 5-5 by setting parameters C07-0 to 9 as shown in Fig. 5-7.

For example if C07-0 (speed setting 1) is set to “0” this function is disabled; if it is set to “1” the speed setting function is fixed at 100%, but if C07-0 is set to “3”, then the speed setting 1 function can be controlled by terminal board input FSI. More details are given in section 6 (C07 parameter list).

An analog interface option type: U2KV23AD0 is necessary to use the additional analog inputs PAI1 to 3.

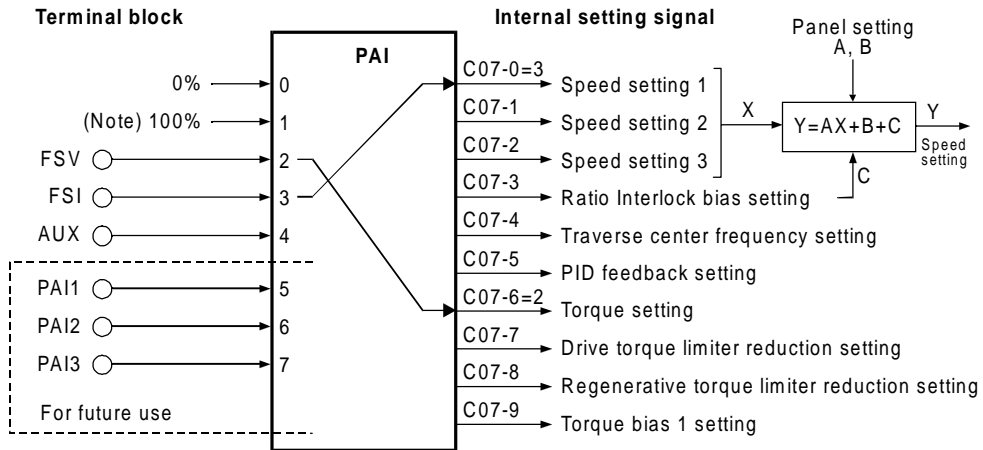

(Note) The torque setting is 300% when C07-6 is 1.

Fig. 5-7 Analog input assignment

The sequential ratio operation can be carried out in respect to speed settings 1 to 3. (Refer to 6-6.)

## 5-8 Programmable analog output function (PAO)

### 5-8-1 Types of analog outputs

As a standard, there are two programmable analog outputs (10 bits) in the VAT2000, with terminal board numbers FM-COM, and AM-COM. Two more analog outputs are available by the optional PCB U2KV23TR0 (Trace Back option).

Each output can be programmed with the internal functions shown in Fig. 5-8. As default, FM is assigned as “output frequency” and AM is assigned as “Motor output current”.

Default settings

Terminal symbol	Setting
FM	Output frequency
AM	Output current (Motor)

### 5-8-2 Setting the analog output

The following internal data or functions can be output to FM, AM terminals by parameters C13-0 and C13-1 as shown in Fig. 5-8.

The extended analog outputs AO1 and AO2, can be addressed with the internal data by parameters C39-0 and C39-1.

If needed, the gain of analog outputs can be adjusted by parameters C14-0, C14-1.

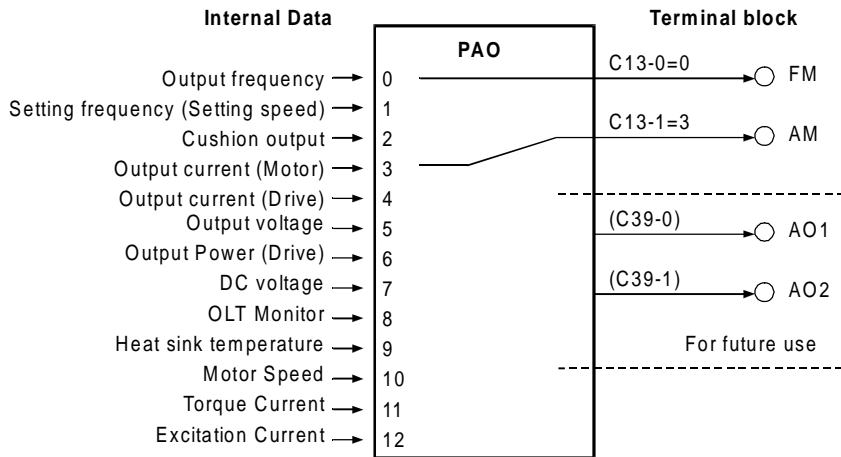

Fig. 5-8 Analog output assignment

## 5-9 Selecting the setting data

### 5-9-1 Speed setting

#### (1) Speed setting selection

The speed setting in VAT2000 is possible from either analog input signals, or from host computer or from the operation panel. There are a total of nine different setting, all selectable.

Setting input point	Setting data	Explanation
Analog	Analog speed setting 1 Analog speed setting 2 Analog speed setting 3	The speed setting is possible from either of three analog inputs provided as standard in the VAT2000.
Serial or parallel	Serial speed setting	The speed setting is allowed from a host computer, through the programmer port or using the serial interface option U2KV23SL0, or optional Profibus DP interface.
	Parallel speed setting	The speed setting is allowed from a host PLC with parallel transmission. A PC interface option type U2KV23PIO is required.
Operation panel	Speed setting	The speed setting is allowed by parameter (A00-0 or 2).
	Panel jogging setting	The speed setting is allowed by parameter (A00-1, 3).
	Traverse operation	The speed setting is allowed by parameters (B44-0 to 6), when the "Traverse" function is enabled.
	Pattern Run operation	The speed setting is allowed by parameters (B50-0 to B59-3), when the Pattern Run function is enabled

#### (2) Speed setting selection sequence

The ratio of the speed setting (Ratio Interlock) and sequence control for signals is shown below. Refer to Section 6-5, B06 (Ratio interlock setting) for details.

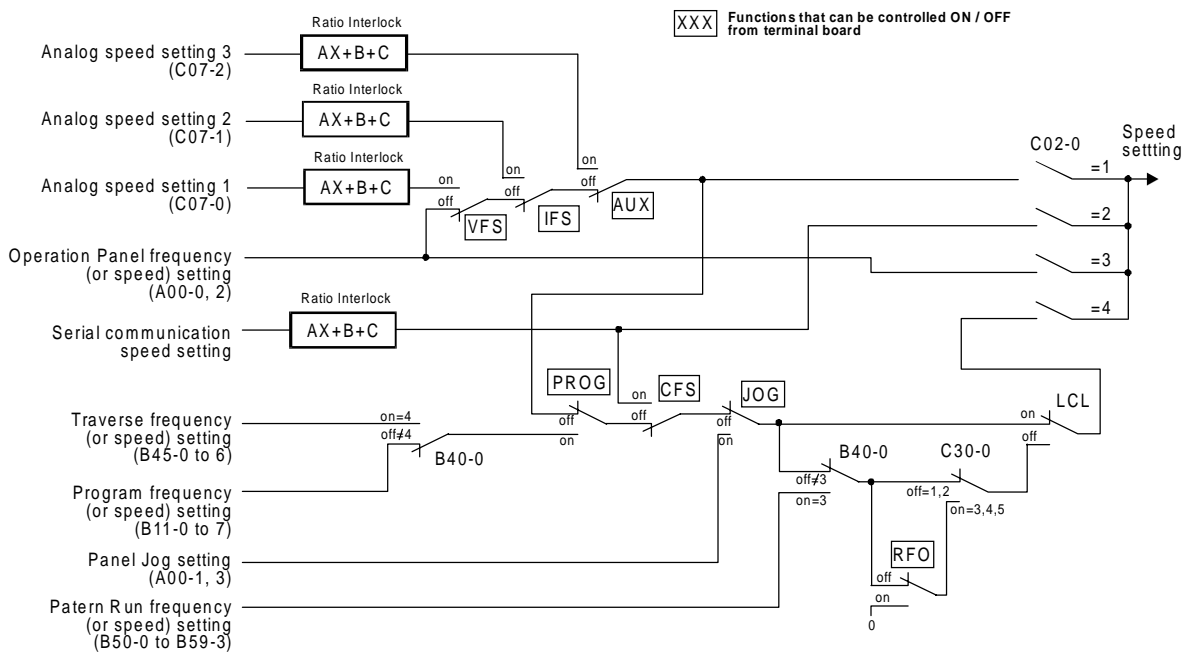

Fig. 5-9 Speed setting selection

5-9-2 Torque setting

(1) Torque setting selection

The torque setting in VAT2000 is possible from either analog signals, serial communications or from the operation panel. All these are selectable by the user.

Setting input point	Setting data	Explanation
Analog	Analog torque setting	The torque setting is possible from the analog input.
Serial	Serial torque setting	The torque setting is allowed from a host computer with serial transmission. A serial interface option type U2KV23SL0 is required.
Panel	Panel torque setting	The torque setting is allowed by parameter (B13-2).

(2) Torque setting selection sequence

The torque setting interlock sequence is shown below.

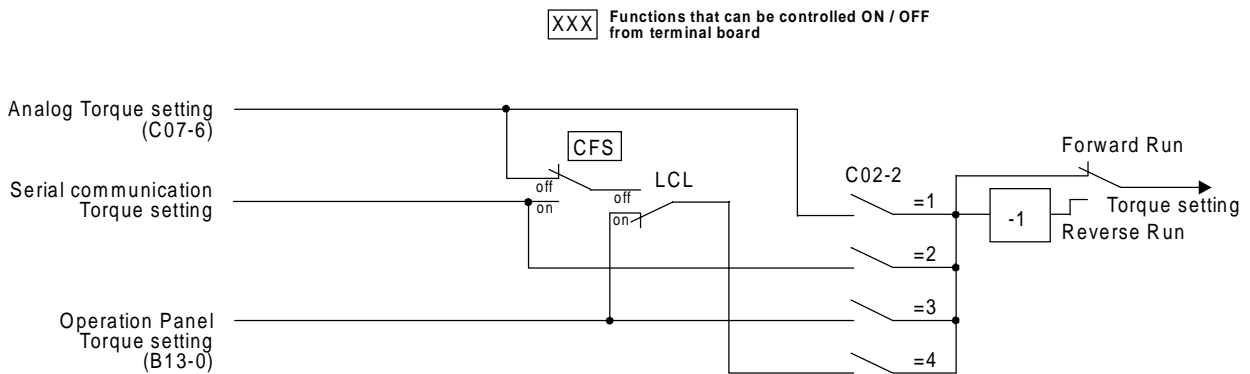

Fig. 5-10 Torque setting selection

5-9-3 Torque bias 1 setting

(1) Torque bias 1 setting selection

A torque bias setting is possible from either analog signals, serial communications or from the operation panel. All these are selectable by the user.

Setting input point	Setting data	Explanation
Analog	Analog torque bias 1 setting	This torque bias setting is possible from an analog input.
Serial	Serial torque bias 1 setting	This torque setting is allowed from a host computer with serial transmission. A serial interface option type U2KV23SL0 is required.
Panel	Panel torque bias 1 setting	This torque bias setting is allowed by parameter (B13-0).

(2) Torque bias 1 setting selection sequence

The relation of the torque bias 1 setting and changeover sequence is shown below.

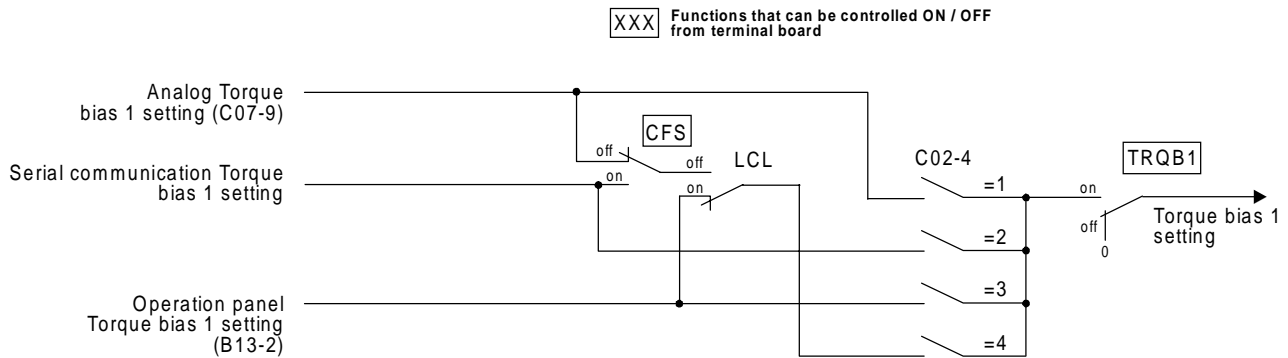

Fig. 5-11 Torque bias 1 setting selection

5-9-4 Torque limiter function

(1) Torque limit setting selection

The torque limit can be set independently for both speed control (ASR mode) or torque control (ACR mode) independently for drive or regeneration status. If the VAT2000 is stopped by the emergency stop signal (EMS), then the regeneration limit is fixed by parameter A10-5. The parameters used in the torque limiter function are shown below..

- A10-3 : ASR drive torque limit setting
- A10-4 : ASR regenerative torque limit setting
- A10-5 : Emergency stop regenerative torque limit setting
- A11-2 : ACR drive torque limit setting
- A11-3 : ACR regenerative torque limit setting

The value of above limits can be reduced by external settings. The final limit value results multiplying the above selected limit with the reduction ratio.

## 5. Control Input / Output

### (1-1) External reduction setting

The torque limit can be reduced using the signal provided from an analog input or from the serial transmission. Either analog or serial signals can be selected by setting a parameter or from the drive's terminal board.

Setting input point	Setting data	Explanation
Analog	Analog drive torque limit reduction setting	The drive torque limit (A10-3 or A11-2) may be reduced in percentage using an analog input. For example using a signal of 0V to +10V the limit torque is reduced from 0 to 100%. This function is enabled when LIM1, is ON.
	Analog regenerative torque limit reduction setting	The regenerative torque limit (A10-4, A10-5 or A11-3) may be reduced in percentage using an analog input. For example using a signal of 0V to +10V the limit torque is reduced from 0 to 100%. This function is enabled when LIM2 is ON.
Serial	Serial drive torque limit reduction setting	A serial interface option U2KV23SL0. The drive torque limit (A10-3, A11-2), may be reduced in a percentage using the data 0 to 100% provided from serial transmission. For example using a signal of 0 to 100% the limit torque is reduced from 0 to 100%. This function is enabled when LIM1 is ON.
	Serial regenerative torque limit reduction setting	A serial interface option U2KV23SL0 The regenerative torque limit (A10-4, A10-5, A11-3), may be reduced in a percentage using the data 0 to 100% provided from serial transmission. For example using a signal of 0 to 100% the limit torque is reduced from 0 to 100%. This function is enabled when LIM2 is ON.

### (1-2) Internal reduction setting

The torque limit may be reduced as well by setting a value lower than 100% in the parameter "Double rating speed ratio", B13-4. The reduction generated in the limiter function, in percentage, is shown below, and will depend of the base speed and real speed ratio. The resultant multiplier will reduce the limit values set in A10-3, A11-2, A10-4, A10-5 and A11-3.

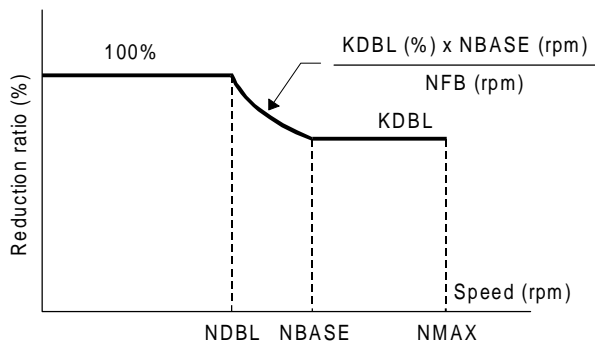

**KDBL** : B13-4  
 Double rating speed ratio (%)  
**NFB** : Speed detection (rpm)  
**NBASE** : Base speed (rpm)  
**NDBL** : NBASE x KDBL (rpm)

(2) Torque limit setting selection sequence

The interlock sequence for torque limit settings is shown below.

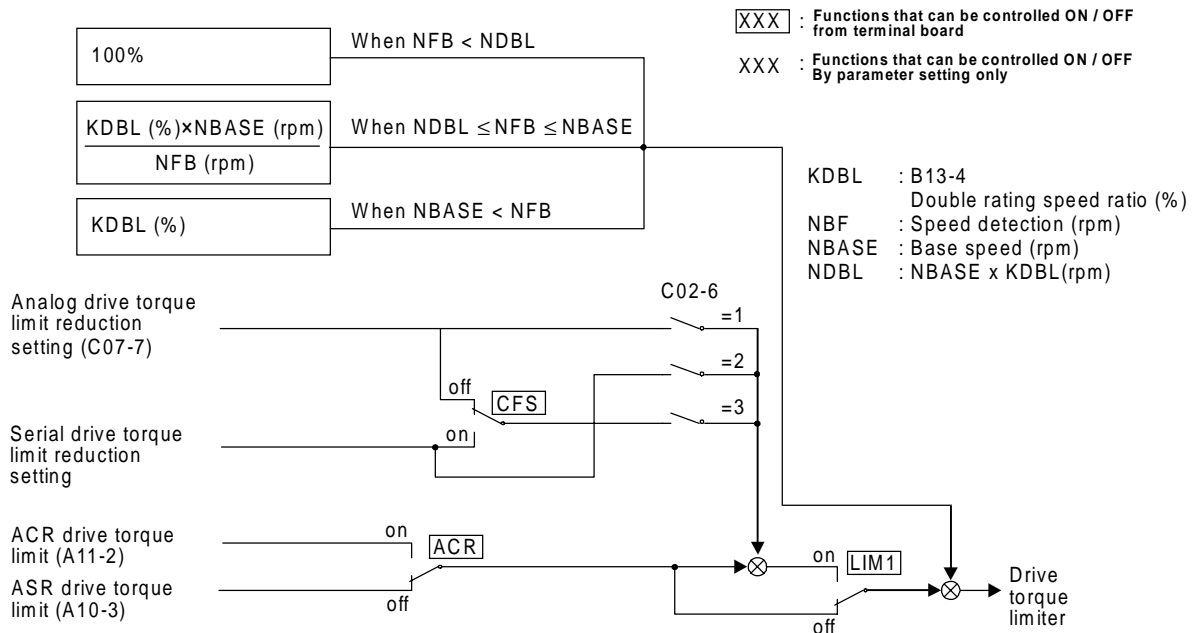

Fig. 5-12 Drive torque limit setting selection

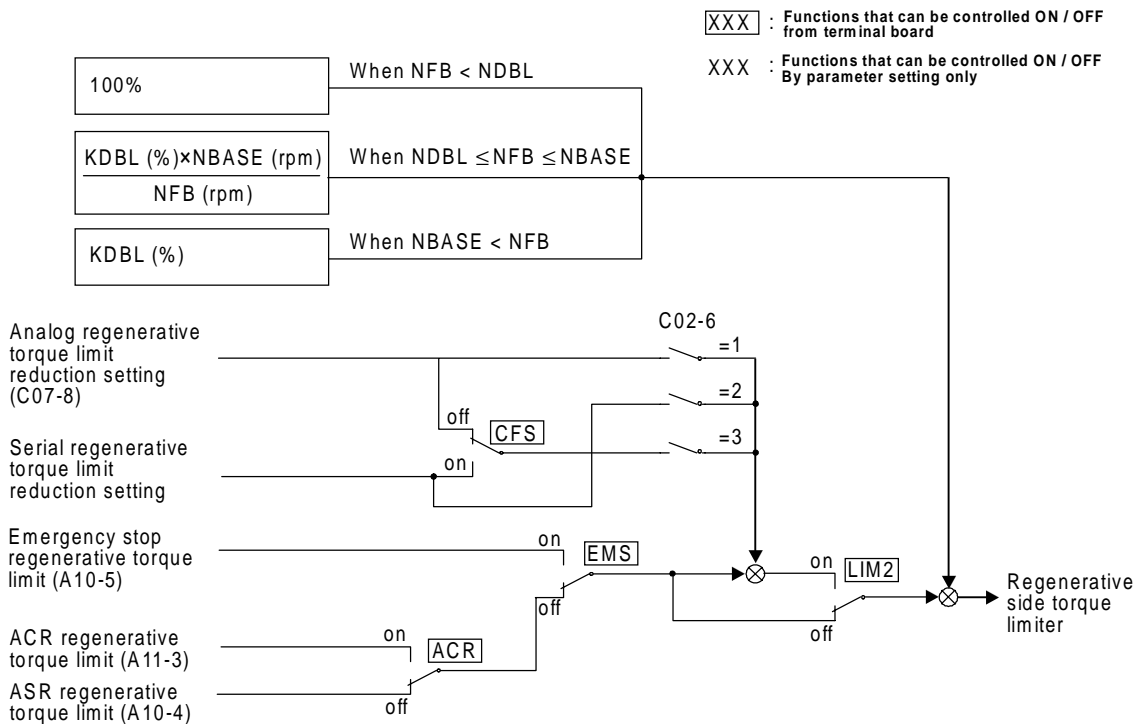

Fig. 5-13 Regenerative torque limit setting selection

5-9-5 Torque ratio 1 setting

(1) Torque ratio 1 setting selection

The torque setting from ASR or from the outside can be operated with the multiplier factor given by function "Torque ratio 1". This function can be set from either the Operation Panel or from the serial communication function.

Setting input point	Setting data	Explanation
Serial	Torque ratio 1 setting	This is a setting value allowed from the host computer with serial transmission.
Panel	Panel torque ratio 1 setting	This is a setting value allowed from the parameter (B13-1).

(2) Torque ratio 1 setting selection sequence

The interlock sequence for the Torque ratio 1 setting is shown below.

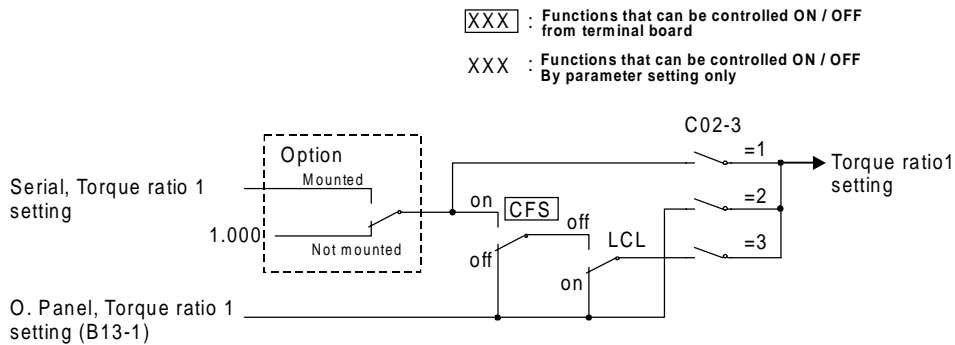

Fig. 5-14 Torque ratio 1 setting selection

5-9-6 Torque ratio 2, torque bias 2 setting

(1) Torque ratio 2 setting selection

The following two types of torque ratio 2 setting inputs can be used.  
One of the two types of inputs can be selected by setting a parameter or with the sequence input.

Setting input point	Setting data	Explanation
Serial	IO link II torque ratio 2 setting	This is a setting value issued from the host computer with serial transmission. An IO link II serial interface option (type: U2KV23SL2) is required.
Panel	Panel torque ratio 2 setting	This is a setting value issued from the parameter (B13-3).

(2) Torque ratio 2 setting selection sequence

The relation of the torque ratio 2 setting and changeover sequence is as shown below.

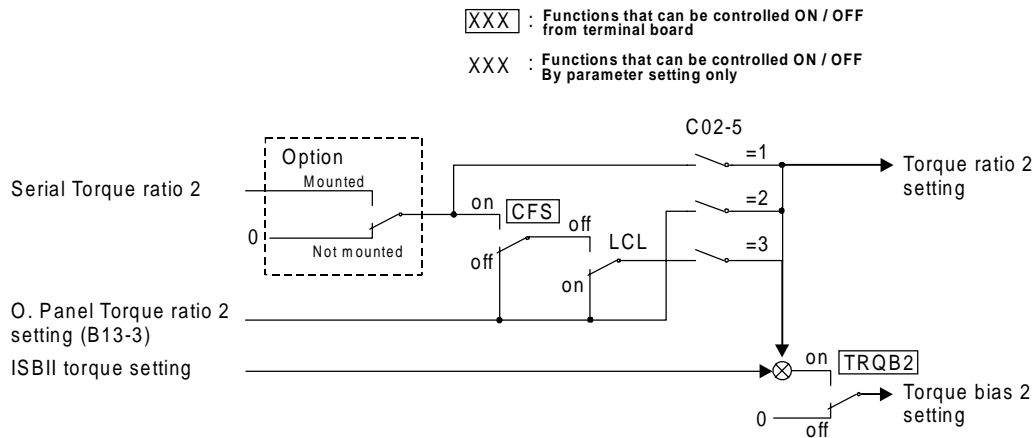

Fig. 5-15 Torque ratio 2 setting selection

5-9-7 Machine time constant setting

(1) Machine time constant setting

The ASR need acknowledge of machine (load) time constant. This value can be set from either serial communication or through the Operation panel (this allows two different settings). One of the three types of inputs can be selected by setting a parameter or with the sequence input.

Setting input point	Setting data	Explanation
Serial	Machine time constant	This is a setting value issued from the host computer by serial transmission.
Panel	O. Panel machine time constant -1	This is a setting value issued from the parameter (A10-1).
	O. Panel machine time constant -2	This is a setting value issued from the parameter (B15-0).

(2) Machine time constant setting and changeover sequence

The interlock sequence for the machine time constant setting is shown below.

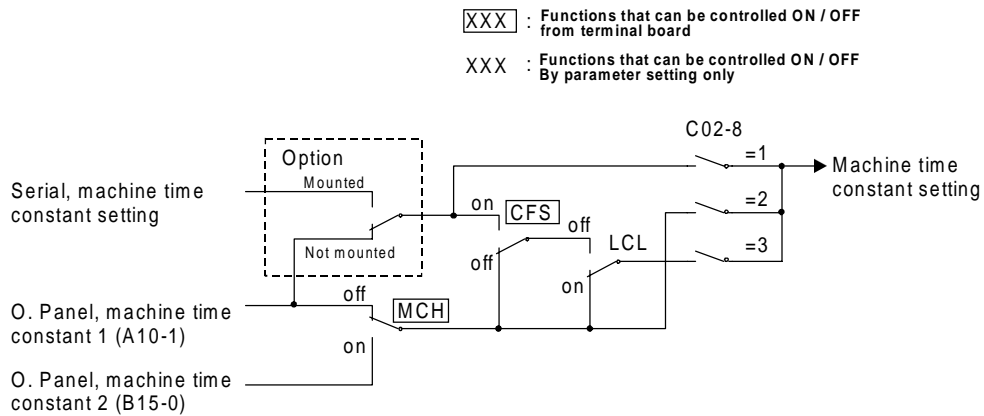

Fig. 5-16 Machine time constant setting selection

5-9-8 ASR response setting

(1) ASR response setting selection

The ASR need acknowledge of the response time required. This value can be set from either serial communication or through the Operation panel.

Setting input point	Setting data	Explanation
Serial	ASR response setting	This is a setting value issued from the host computer with serial transmission.
Panel	O. Panel ASR response setting	This is a setting value issued from the parameter (A10-0).

(2) ASR response setting and changeover sequence

The interlock sequence for the ASR response setting is shown below.

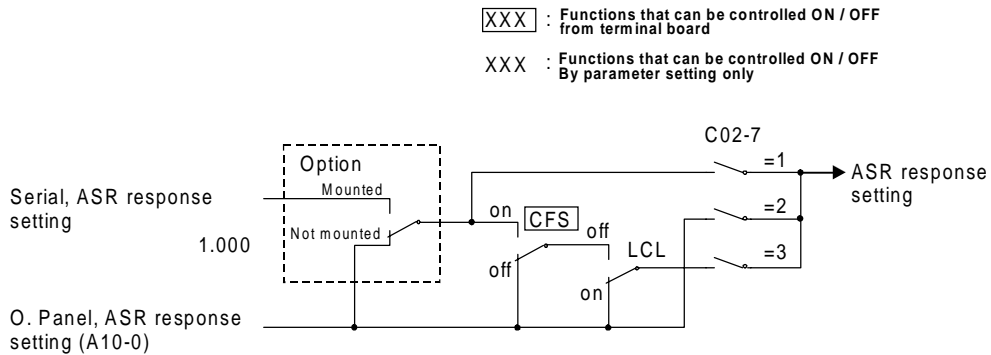

Fig. 5-17 ASR response setting selection

## Chapter 6 Control Functions and Parameter Settings

### 6-1 Monitor parameters

#### 6-1 Monitor parameters

The monitor mode sequentially displays the frequency, power supply, etc., parameters recognised by the VAT2000.

The symbols used in the “Application” column are:

**ST** : Indicates parameters used for all control modes (C30-0 = 1 to 5) including V/f control (constant torque, variable torque), sensor-less vector control, and vector control with sensor and PM motor control.

**V/f** : Indicates parameters used for V/f control (constant torque, variable torque) (C30-0 = 1, 2).

**VEC** : Indicates parameters used for IM sensor-less vector control and IM vector control with sensor (C30-0 = 3, 4).

**PM** : Indicates parameters that are used for PM motor control (C30-0=5)

#### Monitor parameters list

No.	Parameter	Unit	Remarks	Application			
				ST	V/f	VEC	PM
<b>D00 – Output frequency monitor</b>							
0	Output frequency in Hz	Hz	0000 will display when the VAT2000 is in standby.	○			
1	Output frequency in %	%	000 displays while the DC brake is in action. 000 is displayed during pick up (Flying Start).				
2	Motor speed in min <sup>-1</sup>	min <sup>-1</sup>	The forward run direction is displayed with the + polarity, and the reverse run direction with the – polarity. (This is displayed even when stopped.)			○	○
3	Motor speed in %	%					
<b>D01 – Frequency setting monitor</b>							
0	Setting frequency in Hz	Hz	The currently selected frequency setting value is displayed.		○		
1	Setting frequency in %	%	The max. frequency is displayed as 100%.		○		
3	Setting speed (Output Ramp)	min <sup>-1</sup>	The set speed at ASR input point is displayed. The forward run direction is displayed with the + polarity, and the reverse run direction with the – polarity.			○	○
4	Setting speed (Input Ramp)	min <sup>-1</sup>	The set speed at the ramp function's input point is displayed. The forward run direction is displayed with the + polarity, and the reverse run direction with the – polarity.			○	○
<b>D02 – Current monitor</b>							
0	Output current Amps	A	0000 will display when the VAT2000 is in standby.	○			
1	Output current in %	%	The motor rated current is displayed as 100%.	○			
2	Overload (OLT) monitor	%	OLT functions when this value reaches 100%.	○			
3	Heatsink temperature	°C		○			
4	Torque current detection	%	The torque current detection value is displayed using the motor rated current as 100%. The forward run direction torque is displayed with the + polarity, and the reverse run direction torque with the – polarity.			○	○
5	Excitation current detection	%	The excitation current value is displayed using the motor rated current as 100%.			○	○
<b>D03 – Voltage monitor</b>							
0	DC voltage	V	Displays the voltage of the DC link circuit in the main circuit.	○			
1	Output voltage (command)	V	Displays output voltage command. The display may differ from the actual output voltage. 0000 will display when the drive is in standby.	○			
2	Output power	kW	Displays the inverter's output power. 0000 will display when the drive is in standby.	○			
3	Carrier frequency	kHz	The current carrier frequency is displayed.	○			
<b>D04 – Sequence status</b>							
0 ~ 2	Input		The ON/OFF state of the internal sequence data will display.	○			
3 ~ 4	Output		The correspondence of each LED segment and signal is shown in the next page.	○			

## 6. Control Functions and Parameter Settings

### Monitor parameters list

No.	Parameter	Unit	Remarks	Application			
				ST	V/f	VEC	PM
<b>D05 – Minor fault monitor</b>							
0	Minor fault		The internal minor fault status will display. The correspondence of each LED segment and signal is shown in the next page.	○			
<b>D06 – Pattern run monitor</b>							
0	Step number		Displays the current operation step number.	○			
1	Remaining time	Hrs	Displays the remaining time of current step.	○			
<b>D07 – Pump operation status monitor</b>							
0	Pump operation status		Displays the ON/OFF status of the pumps The correspondence of each LED segment and signal is shown below.	○			
1	Next ON pump No.		"0" is displayed when all pumps are ON	○			
2	Next OFF pump No.		"0" is displayed when all pumps are OFF	○			
3	Passage time	Hrs	Displays the continuous ON /OFF time of the current pump. It is cleared when the pump operation is changeover	○			

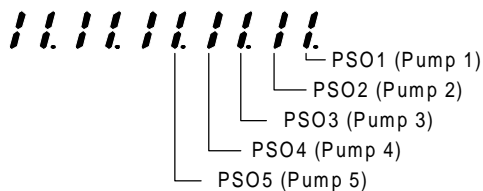

**Pump operation status monitor (D07-0)**

## 6. Control Functions and Parameter Settings

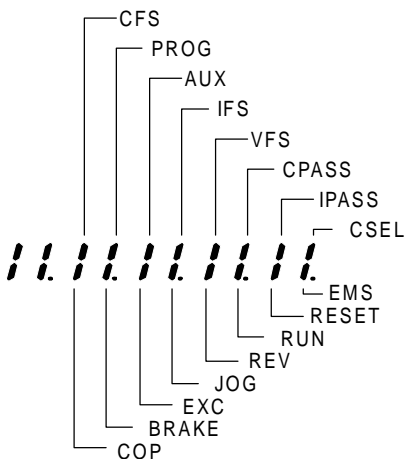

**Sequence input (D04-0)**

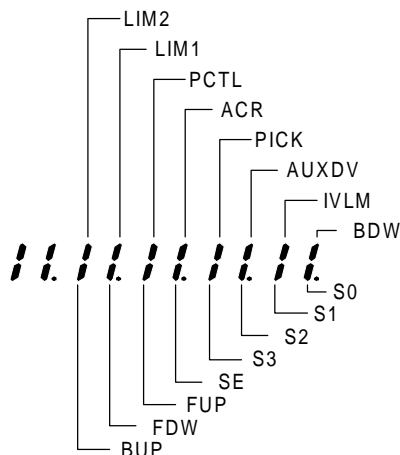

**Sequence input (D04-1)**

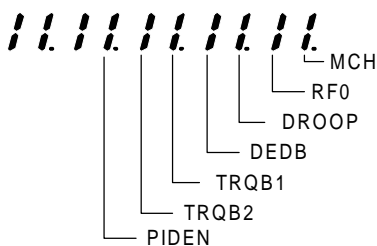

**Sequence input (D04-2)**

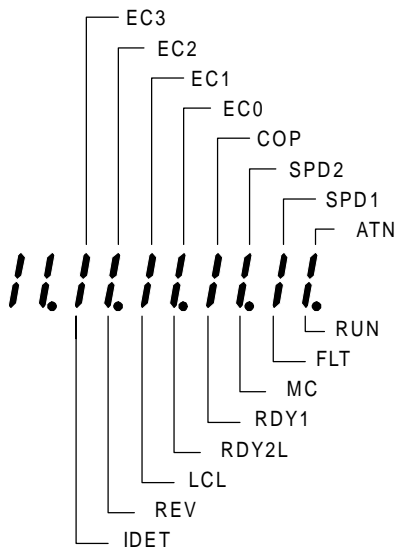

**Sequence output (D04-3)**

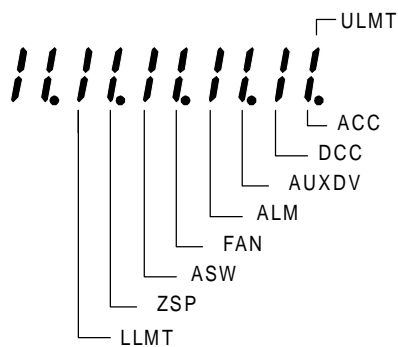

**Sequence output (D04-4)**

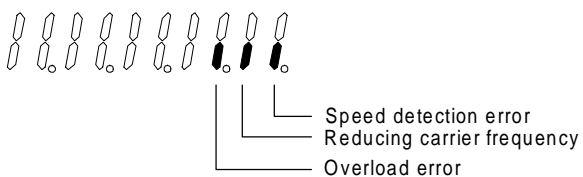

**Minor fault monitor (D05-0)**

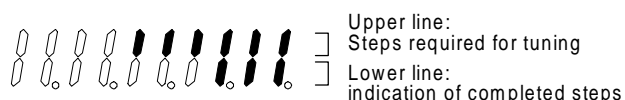

**Automatic tuning progression (D22-0)**

## 6. Control Functions and Parameter Settings

### Monitor parameters list

No.	Parameter	Unit	Remarks	Application			
				ST	V/f	VEC	PM
<b>D11 – Torque setting</b>							
0	Torque setting	%	The currently selected torque setting is displayed.			○	○
1	Analog torque setting	%	The setting value from the analog torque input is displayed.			○	○
2	Serial communication torque setting	%	The setting value from the serial communication torque input setting is displayed.			○	○
3	Operation panel torque setting	%	The torque set with the operation panel (B13-0) is displayed.			○	○
4	ASR output	%	The ASR output is displayed.			○	○
5	Torque setting (after torque limiter function)	%	The forward run direction torque is displayed with the (+) polarity, and the reverse run direction torque with the (-) polarity.			○	○
<b>D12 – Slip</b>							
0	Slip	%	The slip is displayed as a percentage in respect to the base speed.			○	
<b>D20 – Extended monitor</b>							
0	Fault history reading entry		The last four fault history will display when <b>SET</b> is pressed.	○			
2	Non-default value parameter list mode entry		The parameters that differ from the default factory settings are displayed when key <b>SET</b> is pressed.	○			
<b>D21 – Maintenance monitor</b>							
0	Cumulative Power On time	Hrs	Displays the cumulative power ON time.	○			
1	Cumulative run time	Hrs	Displays the cumulative run time.	○			
2	CPU version		Display the CPU serial number.	○			
3	ROM version		Display the ROM serial number.	○			
<b>D22 – Automatic tuning</b>							
0	Automatic tuning progression display		Displays the progression of the automatic tuning.		○	○	
<b>D30 – Hardware monitor</b>							
0	Inverter type		This indicates the inverter type	○			
1	Option PCB		This indicates the mounted optional PCB. The correspondence of the LED signals is shown below	○			

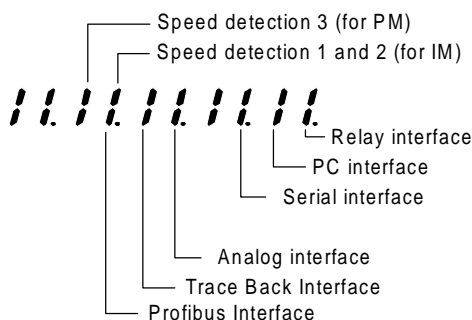

**Option PCB monitor (D30-1)**

## 6. Control Functions and Parameter Settings

### 6-2 Block-A parameters

The parameters used most frequently have been grouped in Block-A.

#### Block-A parameters list

No.	Parameter	Unit	Default	Min.	Max.	Function	Application			
							ST	V/f	VEC	PM
<b>A00 – Frequency setting</b>										
0	Local frequency setting	Hz	10.00	0.10	Max. frequency	This is the frequency set from the operation panel.		○		
1	Frequency setting for jogging	Hz	5.00	0.10	Max. frequency	This is the frequency setting for jogging.		○		
2	Local speed setting	min <sup>-1</sup>	300.0	–Max. speed	Max. speed	This is the speed set from the operation panel.			○	○
3	Speed setting for jogging	min <sup>-1</sup>	100.0	–Max. speed	Max. speed	This is the speed setting for jogging.			○	○
<b>A01 – Acceleration/deceleration time</b>										
0	Acceleration time – 1	sec	10.0	0.1	6000.0	This is the time to reach the max. frequency or max. speed from 0	○			
1	Deceleration time – 1	sec	20.0	0.1	6000.0	This value can be set x0.1 or x10 units by setting the parameter B10-5 accordingly.	○			
<b>A02 – Torque boost</b>										
0	Manual torque boost selection		2.	1.	2.	1: Disable = 2: Enable		○		
1	Automatic torque boost selection		1.	1.	2.	1: Disable = 2: Enable		○		
2	Manual torque boost setting	%	Inverter rating	0.0	20.0	This is the boost voltage at 0Hz. This is automatically adjusted by the automatic tuning.		○		
3	Square reduction torque setting	%	0.0	0.0	25.0	This is the reduced voltage at half of base frequency.		○		
4	R1 drop compensation gain	%	50.0	0.0	100.0	This is the voltage compensation because R1 drop		○		
5	Slip compensation gain	%	0.0	0.0	20.0	This is the motor's rated slip. This is automatically adjusted by the automatic tuning.		○		
6	Maximum torque boost gain	%	0.0	0.0	50.0	This is automatically adjusted by the automatic tuning.		○		
<b>A03 – DC Brake</b>										
0	DC braking voltage	%	Inverter rating	0.1	20.0	This is automatically adjusted by the automatic tuning.		○		
1	DC braking time	sec	2.0	0.0	20.0		○			
2	DC braking current	%	50.	0.	150.				○	○
<b>A04 – Custom parameters</b>										
0	Custom– 0					Set the parameter Nos. to be displayed in this block in C10-0~7.	○			
1	– 1									
2	– 2									
3	– 3									
4	– 4									
5	– 5									
6	– 6									
7	– 7									
<b>A05 – Block B, C parameter skip</b>										
0	Extended setting		2.	1.	2.	= 1 : Display, = 2 : Skip	○			
1	Software option function		2.	1.	2.	= 1 : Display, = 2 : Skip	○			
2	Hardware option function		2.	1.	2.	= 1 : Display, = 2 : Skip	○			

## 6. Control Functions and Parameter Settings

### Block-A parameters list

No.	Parameter	Unit	Default	Min.	Max.	Function	Application			
							ST	V/f	VEC	PM
<b>A10 – ASR control constant 1</b>										
0	ASR response	rad/s	20.0	1.0	200.0	This is the required ASR response in radian/sec.			<input type="radio"/>	<input type="radio"/>
1	Machine time constant1	ms	1000.	1.	20000.	This is the time to accelerate the motor + load to the base speed at the motor rated torque.			<input type="radio"/>	<input type="radio"/>
2	Integral time constant compensation coefficient	%	100.	20.	500.	This is a compensation coefficient for the Integral time constant in the speed regulator.			<input type="radio"/>	<input type="radio"/>
3	ASR drive torque limit	%	100.0	0.1	300.0	These are the drive and regenerative torque limit values for ASR operation. (Speed Control)			<input type="radio"/>	<input type="radio"/>
4	ASR regenerative torque limit	%	100.0	0.1	300.0				<input type="radio"/>	<input type="radio"/>
5	Emergency stop regenerative torque limit	%	100.0	0.1	300.0	This is the regenerative torque limit used during the emergency stop (EMS)			<input type="radio"/>	<input type="radio"/>
<b>A11 – ACR control constant</b>										
0	ACR response	rad/s	1000.	100.	6000.	The ACR gain and time constant are set. This will affect the current response. If the gain is too low or too high, the current will become unstable, and the over current protection will function. Normally adjust the response between 500 and 1000, and the time constant between 5 and 20ms.			<input type="radio"/>	
1	ACR time constant	ms	20.0	0.1	300.0				<input type="radio"/>	
2	ACR drive torque limit	%	100.0	0.1	300.0	Drive and regenerative torque limit values for ACR operation.			<input type="radio"/>	<input type="radio"/>
3	ACR regenerative torque limit	%	100.0	0.1	300.0	(Torque Control)			<input type="radio"/>	<input type="radio"/>
<b>A20 – ACR control constant (Permanent Magnet Motors)</b>										
0	ACR response (PM)	rad/s	1500	100.	6000.	These are the gain and time constant for the current regulator (ACR) This will affect the current response. If the gain is too low or too high, the current will become unstable, and the VAT2000 may trip by overcurrent . In general, adjust the response between 500 and 1000, and the time constant between 5 and 20ms.				<input type="radio"/>
1	ACR time constant (PM)	ms	10.0	0.1	300.0					<input type="radio"/>
2	d axis current command ramp time	ms/l1	10.0	0.1	100.0	This is the ramp setting to prevent instability caused by overshooting, etc when current command changes suddenly. Set usually a value of 5-10 ms				<input type="radio"/>
3	q axis current command ramp time	ms/l1	10.0	0.1	100.0					<input type="radio"/>

## 6. Control Functions and Parameter Settings

### 6-3 Block-B parameters

The Block-B parameters are divided into the basic functions, extended functions and software option functions.

#### Block-B parameters (Basic function of V/f control) list

No.	Parameter	Unit	Default	Min.	Max.	Function	Application																																																																			
							ST	V/f	VEC	PM																																																																
<b>B00 – Output rating</b>																																																																										
0	Rated input voltage setting		7.	1.	7.	Select the rated input voltage from the following table.		○																																																																		
			<p style="text-align: center;"><b>Drives up to U2KN37K0 or U2KX45K0      Drives Larger than U2X45K0</b></p> <table style="width: 100%; border-collapse: collapse;"> <tr> <td style="width: 30%;"></td> <td style="width: 15%;"><b>Value</b></td> <td style="width: 15%;"><b>200V System</b></td> <td style="width: 15%;"><b>400V System</b></td> <td style="width: 15%;"></td> <td style="width: 15%;"><b>Value</b></td> <td style="width: 15%;"><b>200V System</b></td> <td style="width: 15%;"><b>400V System</b></td> </tr> <tr> <td>When this data is changed, the output voltage data will be changed to the same value.</td> <td>1</td> <td>200V</td> <td>380V</td> <td></td> <td>1</td> <td>200V</td> <td>380V</td> </tr> <tr> <td></td> <td>2</td> <td>200V</td> <td>400V</td> <td></td> <td>2</td> <td>200V</td> <td>400V</td> </tr> <tr> <td></td> <td>3</td> <td>200V</td> <td>415V</td> <td></td> <td>3</td> <td>220V</td> <td>415V</td> </tr> <tr> <td></td> <td>4</td> <td>220V</td> <td>440V</td> <td></td> <td>4</td> <td>220V</td> <td>440V</td> </tr> <tr> <td></td> <td>5</td> <td>230V</td> <td>460V</td> <td></td> <td>5</td> <td>230V</td> <td>460V</td> </tr> <tr> <td></td> <td>6</td> <td>230V</td> <td>480V</td> <td></td> <td>6</td> <td>230V</td> <td>460V</td> </tr> <tr> <td></td> <td>7</td> <td>230V</td> <td>400V</td> <td></td> <td>7</td> <td>230V</td> <td>400V</td> </tr> </table>									<b>Value</b>	<b>200V System</b>	<b>400V System</b>		<b>Value</b>	<b>200V System</b>	<b>400V System</b>	When this data is changed, the output voltage data will be changed to the same value.	1	200V	380V		1	200V	380V		2	200V	400V		2	200V	400V		3	200V	415V		3	220V	415V		4	220V	440V		4	220V	440V		5	230V	460V		5	230V	460V		6	230V	480V		6	230V	460V		7	230V	400V		7	230V	400V
	<b>Value</b>	<b>200V System</b>	<b>400V System</b>		<b>Value</b>	<b>200V System</b>	<b>400V System</b>																																																																			
When this data is changed, the output voltage data will be changed to the same value.	1	200V	380V		1	200V	380V																																																																			
	2	200V	400V		2	200V	400V																																																																			
	3	200V	415V		3	220V	415V																																																																			
	4	220V	440V		4	220V	440V																																																																			
	5	230V	460V		5	230V	460V																																																																			
	6	230V	480V		6	230V	460V																																																																			
	7	230V	400V		7	230V	400V																																																																			
1	Max./base frequency simple setting		1.	0	9	Select the output frequency rating from the combination below.		○																																																																		
			<table style="width: 100%; border-collapse: collapse;"> <tr> <td style="width: 30%;"></td> <td style="width: 15%;"><b>Value</b></td> <td style="width: 15%;"><b>Ftrq (Hz)</b></td> <td style="width: 15%;"><b>Fmax (Hz)</b></td> <td style="width: 15%;"></td> <td style="width: 15%;"><b>Value</b></td> <td style="width: 15%;"><b>Ftrq (Hz)</b></td> <td style="width: 15%;"><b>Fmax (Hz)</b></td> </tr> <tr> <td></td> <td>0</td> <td colspan="2">Free setting on B00-4 and B00-5</td> <td></td> <td>6</td> <td>60</td> <td>70</td> </tr> <tr> <td></td> <td>1</td> <td>50</td> <td>50</td> <td></td> <td>7</td> <td></td> <td>80</td> </tr> <tr> <td></td> <td>2</td> <td>60</td> <td>60</td> <td></td> <td>8</td> <td></td> <td>90</td> </tr> <tr> <td></td> <td>3</td> <td>50</td> <td>60</td> <td></td> <td>9</td> <td></td> <td>120</td> </tr> <tr> <td></td> <td>4</td> <td></td> <td>75</td> <td></td> <td></td> <td></td> <td></td> </tr> <tr> <td></td> <td>5</td> <td></td> <td>100</td> <td></td> <td></td> <td></td> <td></td> </tr> </table>									<b>Value</b>	<b>Ftrq (Hz)</b>	<b>Fmax (Hz)</b>		<b>Value</b>	<b>Ftrq (Hz)</b>	<b>Fmax (Hz)</b>		0	Free setting on B00-4 and B00-5			6	60	70		1	50	50		7		80		2	60	60		8		90		3	50	60		9		120		4		75						5		100												
	<b>Value</b>	<b>Ftrq (Hz)</b>	<b>Fmax (Hz)</b>		<b>Value</b>	<b>Ftrq (Hz)</b>	<b>Fmax (Hz)</b>																																																																			
	0	Free setting on B00-4 and B00-5			6	60	70																																																																			
	1	50	50		7		80																																																																			
	2	60	60		8		90																																																																			
	3	50	60		9		120																																																																			
	4		75																																																																							
	5		100																																																																							
2	Motor rated output	kW	Inverter rating	0.10	500.00	Motor rated power at the base speed.		○																																																																		
3	Rated output voltage	V	200 /400.	39.	480.	This is the rated motor voltage, which can not be set to a larger value than the input voltage set in B00-0. The Automatic Voltage regulator DC-AVR does not operate when is set to 39. (then the output voltage equals the input voltage at the base frequency.)		○																																																																		
4	Max. frequency	Hz	50.0	3.0	440.0	When "B00-1" is a value other than 0, these values will be rewritten with the data set in B00-1		○																																																																		
5	Base frequency	Hz	50.0	1.0	440.0			○																																																																		
6	Motor rated current	A	Inverter rating	Inverter rating × 0.3	Inverter rating	The overcurrent limit, OLT, current % display and meter output. are related to this setting		○																																																																		
7	Carrier frequency (Drives up to U2KN37K0 or U2KX45K0)		17.0	1.0	21.0	The noise can be lowered by changing the PWM carrier frequency and control method, which affects to the sound generated from the motor. This can be changed while running. <b>1.0-15.0:</b> Monotone sound method (Carrier frequency: 1.0 to 15.0kHz) <b>15.1-18.0:</b> Soft sound method 1 (Carrier frequency: 2.1 to 5.0kHz) <b>18.1 to 21.0:</b> Soft sound method 2 (Carrier frequency: 2.1 to 5.0kHz)		○																																																																		
	Carrier frequency (Drives larger than U2KX45K0)		10.0	1.0	14.0	<b>1.0-8.0:</b> Monotone sound method (Carrier frequency: 1.0 to 15.0kHz) <b>8.1-11.0:</b> Soft sound method 1 (Carrier frequency: 2.1 to 5.0kHz) <b>11.1 to 14.0:</b> Soft sound method 2 (Carrier frequency: 2.1 to 5.0kHz)		○																																																																		

## 6. Control Functions and Parameter Settings

### Block-B parameters (Basic function of vector control) list

No.	Parameter	Unit	Default	Min.	Max.	Function	Application																																																			
							ST	V/f	VEC	PM																																																
<b>B01 – Output rating</b>																																																										
0	Rated input voltage setting		7.	1.	7.	Select the rated input voltage from the following table.			<input type="radio"/>	<input type="radio"/>																																																
			<b>Drives up to U2KN37K0 or U2KX45K0</b>			<b>Drives Larger than U2X45K0</b>																																																				
			When this data is changed, the output voltage data will be changed to the same value.																																																							
			<table border="1" style="width: 100%; border-collapse: collapse; text-align: center;"> <thead> <tr> <th>Value</th> <th>200V System</th> <th>400V System</th> </tr> </thead> <tbody> <tr><td>1</td><td>200V</td><td>380V</td></tr> <tr><td>2</td><td>200V</td><td>400V</td></tr> <tr><td>3</td><td>200V</td><td>415V</td></tr> <tr><td>4</td><td>220V</td><td>440V</td></tr> <tr><td>5</td><td>230V</td><td>460V</td></tr> <tr><td>6</td><td>230V</td><td>480V</td></tr> <tr><td>7</td><td>230V</td><td>400V</td></tr> </tbody> </table>			Value	200V System	400V System	1	200V	380V	2	200V	400V	3	200V	415V	4	220V	440V	5	230V	460V	6	230V	480V	7	230V	400V	<table border="1" style="width: 100%; border-collapse: collapse; text-align: center;"> <thead> <tr> <th>Value</th> <th>200V System</th> <th>400V System</th> </tr> </thead> <tbody> <tr><td>1</td><td>200V</td><td>380V</td></tr> <tr><td>2</td><td>200V</td><td>400V</td></tr> <tr><td>3</td><td>220V</td><td>415V</td></tr> <tr><td>4</td><td>220V</td><td>440V</td></tr> <tr><td>5</td><td>230V</td><td>460V</td></tr> <tr><td>6</td><td>230V</td><td>460V</td></tr> <tr><td>7</td><td>230V</td><td>400V</td></tr> </tbody> </table>			Value	200V System	400V System	1	200V	380V	2	200V	400V	3	220V	415V	4	220V	440V	5	230V	460V	6	230V	460V	7	230V	400V		
Value	200V System	400V System																																																								
1	200V	380V																																																								
2	200V	400V																																																								
3	200V	415V																																																								
4	220V	440V																																																								
5	230V	460V																																																								
6	230V	480V																																																								
7	230V	400V																																																								
Value	200V System	400V System																																																								
1	200V	380V																																																								
2	200V	400V																																																								
3	220V	415V																																																								
4	220V	440V																																																								
5	230V	460V																																																								
6	230V	460V																																																								
7	230V	400V																																																								
1	Motor rated output	kW	Inverter rating	0.10	500.00	Motor rated power at the base speed			<input type="radio"/>	<input type="radio"/>																																																
2	No. of motor poles	Pole	4.	2.	16.				<input type="radio"/>	<input type="radio"/>																																																
3	Rated output voltage	V	200 /400.	40.	480.	This is the motor rated voltage at base speed, full load			<input type="radio"/>	<input type="radio"/>																																																
4	Max. speed	min <sup>-1</sup>	1800.	150.	7200.	This is the max. motor speed. The maximum frequency is 120Hz.			<input type="radio"/>	<input type="radio"/>																																																
5	Base speed	min <sup>-1</sup>	1800.	150.	7200.	This is the motor base (rated) speed. When the motor is controlled above that speed, the flux during vector control will be weakened.			<input type="radio"/>	<input type="radio"/>																																																
6	Motor rated current	A	Inverter rating	Inverter rating × 0.3	Inverter rating	This is the motor current during full load at the base speed.			<input type="radio"/>	<input type="radio"/>																																																
7	Carrier frequency (Drives up to U2KN37K0 or U2KX45K0)		17.0	1.0	21.0	The noise can be lowered by changing the PWM carrier frequency and control method, which affects to the sound generated from the motor. This can be changed while running. 1.0 to 15.0: Monotone sound method (Carrier frequency: 1.0 to 15.0kHz) 15.1 to 18.0: Soft sound method 1 (Basic carrier frequency: 2.1 to 5.0kHz) 18.1 to 21.0: Soft sound method 2 (Basic carrier frequency: 2.1 to 5.0kHz)			<input type="radio"/>	<input type="radio"/>																																																
	Carrier frequency (Drives larger than U2KX45K0S)		10.0	1.0	14.0	<b>1.0 to 8.0:</b> Monotone sound method (Carrier frequency: 1.0 to 8.0kHz) <b>8.1 to 11.0:</b> Soft sound method 1 (Basic carrier frequency: 2.1 to 5.0kHz) <b>11.1 to 14.0:</b> Soft sound method 2 (Basic carrier frequency: 2.1 to 5.0kHz)			<input type="radio"/>	<input type="radio"/>																																																
8	No. of encoder pulses	P/R	1000.	60.	10000.	This must be set in vector control with sensor mode			<input type="radio"/>	<input type="radio"/>																																																
9	No-load output voltage	V	160.	20.	500.	This is the voltage during no-load at the base speed. Adjusted by Auto-tuning			<input type="radio"/>	<input type="radio"/>																																																

## 6. Control Functions and Parameter Settings

### Block-B parameters (Basic function constants) list

No.	Parameter	Unit	Default	Min.	Max.	Function	Application			
							ST	V/f	VEC	PM
<b>B02 – Motor circuit constant (IM)</b>										
0	R1: Primary resistance (Mantissa section)	mΩ	Inverter rating	0.100	9.999	This combination means $R2' = 1.000 \times 10^0$ (mΩ)  The motor circuit constant is set.		<input type="radio"/>	<input type="radio"/>	
1	R1: Primary resistance (Exponent section)		Inverter rating	-3	4			<input type="radio"/>	<input type="radio"/>	
2	R2': Secondary resistance (Mantissa section)	mΩ	1.000	0.100	9.999				<input type="radio"/>	
3	R2': Secondary resistance (Exponent section)		0	-3	4				<input type="radio"/>	
4	Lσ: Leakage inductance (Mantissa section)	mH	1.000	0.100	9.999				<input type="radio"/>	
5	Lσ: Leakage inductance (Exponent section)		0	-3	4				<input type="radio"/>	
6	M': Excitation inductance (Mantissa section)	mH	1.000	0.100	9.999				<input type="radio"/>	
7	M': Excitation inductance (Exponent section)		0	-3	4				<input type="radio"/>	
8	Rm: Iron loss resistance (Mantissa section)	mΩ	1.000	0.100	9.999				<input type="radio"/>	
9	Rm: Iron loss resistance (Exponent section)		0	-3	5			<input type="radio"/>		
<b>B03 – Motor circuit constant (PM)</b>										
0	R1: PM motor primary resistance (Mantissa section)	mΩ	1.000	0.001	9.999	This combination means $R1 = 1.000 \times 10^0$ (mΩ)				<input type="radio"/>
1	R1: PM motor primary resistance (Exponent section)		0	-1	4					
2	Ld: PM motor d axis inductance (Mantissa section)	mH	1.000	0.001	9.999	This combination means $R1 = 1.000 \times 10^0$ (mH)				<input type="radio"/>
3	Lq: PM motor q axis inductance (Mantissa section)	mH	1.000	0.001	9.999					
4	Ld, Lq PM motor inductance (Exponent section)		0	-1	4					
<b>B05 – Frequency skip</b>										
0	Skip frequency – 1	Hz	0.1	0.1	440.0		<input type="radio"/>			
1	Skip band – 1	Hz	0.0	0.0	10.0					
2	Skip frequency – 2	Hz	0.1	0.1	440.0					
3	Skip band – 2	Hz	0.0	0.0	10.0					
4	Skip frequency – 3	Hz	0.1	0.1	440.0					
5	Skip band – 3	Hz	0.0	0.0	10.0					
<b>B06 – Ratio interlock setting</b>										
0	Coefficient		1.000	-10.000	10.000		<input type="radio"/>			
1	Bias	Hz	0.0	-440.0	440.0	The upper limit must be larger than the lower limit.		<input type="radio"/>		
2	Upper limit	Hz	440.00	-440.0	440.00					
3	Lower limit	Hz	0.10	-440.0	440.00					
4	Bias	min <sup>-1</sup>	0.	-7200.	7200.	The upper limit must be larger than the lower limit.			<input type="radio"/>	
5	Upper limit	min <sup>-1</sup>	7200.	-7200.	7200.					
6	Lower limit	min <sup>-1</sup>	-7200.	-7200.	7200.					

## 6. Control Functions and Parameter Settings

### Block-B parameters (Extended function constants) list

No.	Parameter	Unit	Default	Min.	Max.	Function	Application																																																																																																																																							
							ST	V/f	VEC	PM																																																																																																																																				
<b>B10 – Acceleration/deceleration time</b>																																																																																																																																														
0	Acceleration ramp time-2	sec	10.0	0.1	6000.0	This acceleration/deceleration ramp time is valid when the ramp 2 selection is ON (CSEL=ON). This is the time to reach the max. frequency or max. speed from 0. This value can be set x0.1 or x10 units by setting the parameter B10-5 accordingly.  This is the acceleration/deceleration time value when the JOG sequence (F JOG, R JOG) is ON. This value can be set x0.1 or x10 units by setting the parameter B10-5 accordingly.  Set to 1/2 of less of the ramp time. S-type ramp time is allowed by setting this parameter.  The acceleration/deceleration ramp time setting unit can be changed by using a multiplier. <b>1: x1; 2: x0.1; 3: x10</b>	○																																																																																																																																							
1	Deceleration ramp time-2	sec	20.0	0.1	6000.0																																																																																																																																									
2	Acceleration ramp time for jogging	sec	5.0	0.1	6000.0		○																																																																																																																																							
3	Deceleration ramp time for jogging	sec	5.0	0.1	6000.0																																																																																																																																									
4	S-shape characteristics (Ts)	sec	0.0	0.0	5.0		○																																																																																																																																							
5	Time unit		1.	1.	3.	○																																																																																																																																								
<b>B11 – Program frequency (speed) setting</b>																																																																																																																																														
0	Program frequency (speed) –0	%	10.00	0.00	100.00	<b>(1) Binary select mode (B11-8=1)</b> <table border="1" style="width: 100%; border-collapse: collapse;"> <thead> <tr> <th colspan="5">Sequence Command</th> <th>Selected</th> </tr> <tr> <th>SE</th> <th>S3</th> <th>S2</th> <th>S1</th> <th>S0</th> <th>freq.</th> </tr> </thead> <tbody> <tr><td></td><td></td><td>OFF</td><td>OFF</td><td>OFF</td><td>B11-0</td></tr> <tr><td></td><td></td><td>OFF</td><td>OFF</td><td>ON</td><td>B11-1</td></tr> <tr><td></td><td></td><td>OFF</td><td>ON</td><td>OFF</td><td>B11-2</td></tr> <tr><td></td><td></td><td>OFF</td><td>ON</td><td>ON</td><td>B11-3</td></tr> <tr><td></td><td></td><td>ON</td><td>OFF</td><td>OFF</td><td>B11-4</td></tr> <tr><td></td><td></td><td>ON</td><td>OFF</td><td>ON</td><td>B11-5</td></tr> <tr><td></td><td></td><td>ON</td><td>ON</td><td>OFF</td><td>B11-6</td></tr> <tr><td></td><td></td><td>ON</td><td>ON</td><td>ON</td><td>B11-7</td></tr> </tbody> </table> SE and S3 are not used  <b>(2) Direct select mode (B11-8=2)</b> <table border="1" style="width: 100%; border-collapse: collapse;"> <thead> <tr> <th colspan="5">Sequence Command</th> <th>Selected</th> </tr> <tr> <th>SE</th> <th>S3</th> <th>S2</th> <th>S1</th> <th>S0</th> <th>freq.</th> </tr> </thead> <tbody> <tr><td>OFF</td><td>OFF</td><td>OFF</td><td>OFF</td><td>OFF</td><td>Latest value</td></tr> <tr><td>OFF</td><td>OFF</td><td>OFF</td><td>OFF</td><td>ON</td><td>B11-0</td></tr> <tr><td>OFF</td><td>OFF</td><td>OFF</td><td>ON</td><td>OFF</td><td>B11-1</td></tr> <tr><td>OFF</td><td>OFF</td><td>ON</td><td>OFF</td><td>OFF</td><td>B11-2</td></tr> <tr><td>OFF</td><td>ON</td><td>OFF</td><td>OFF</td><td>OFF</td><td>B11-3</td></tr> <tr><td>ON</td><td>OFF</td><td>OFF</td><td>OFF</td><td>OFF</td><td>Latest value</td></tr> <tr><td>ON</td><td>OFF</td><td>OFF</td><td>OFF</td><td>ON</td><td>B11-4</td></tr> <tr><td>ON</td><td>OFF</td><td>OFF</td><td>ON</td><td>OFF</td><td>B11-5</td></tr> <tr><td>ON</td><td>OFF</td><td>ON</td><td>OFF</td><td>OFF</td><td>B11-6</td></tr> <tr><td>ON</td><td>ON</td><td>OFF</td><td>OFF</td><td>OFF</td><td>B11-7</td></tr> </tbody> </table> When S0 to S3 are all OFF the latest frequency set value is hold. After power ON that goes to "0"	Sequence Command					Selected	SE	S3	S2	S1	S0	freq.			OFF	OFF	OFF	B11-0			OFF	OFF	ON	B11-1			OFF	ON	OFF	B11-2			OFF	ON	ON	B11-3			ON	OFF	OFF	B11-4			ON	OFF	ON	B11-5			ON	ON	OFF	B11-6			ON	ON	ON	B11-7	Sequence Command					Selected	SE	S3	S2	S1	S0	freq.	OFF	OFF	OFF	OFF	OFF	Latest value	OFF	OFF	OFF	OFF	ON	B11-0	OFF	OFF	OFF	ON	OFF	B11-1	OFF	OFF	ON	OFF	OFF	B11-2	OFF	ON	OFF	OFF	OFF	B11-3	ON	OFF	OFF	OFF	OFF	Latest value	ON	OFF	OFF	OFF	ON	B11-4	ON	OFF	OFF	ON	OFF	B11-5	ON	OFF	ON	OFF	OFF	B11-6	ON	ON	OFF	OFF	OFF	B11-7	○			
Sequence Command					Selected																																																																																																																																									
SE	S3	S2	S1	S0	freq.																																																																																																																																									
		OFF	OFF	OFF	B11-0																																																																																																																																									
		OFF	OFF	ON	B11-1																																																																																																																																									
		OFF	ON	OFF	B11-2																																																																																																																																									
		OFF	ON	ON	B11-3																																																																																																																																									
		ON	OFF	OFF	B11-4																																																																																																																																									
		ON	OFF	ON	B11-5																																																																																																																																									
		ON	ON	OFF	B11-6																																																																																																																																									
		ON	ON	ON	B11-7																																																																																																																																									
Sequence Command					Selected																																																																																																																																									
SE	S3	S2	S1	S0	freq.																																																																																																																																									
OFF	OFF	OFF	OFF	OFF	Latest value																																																																																																																																									
OFF	OFF	OFF	OFF	ON	B11-0																																																																																																																																									
OFF	OFF	OFF	ON	OFF	B11-1																																																																																																																																									
OFF	OFF	ON	OFF	OFF	B11-2																																																																																																																																									
OFF	ON	OFF	OFF	OFF	B11-3																																																																																																																																									
ON	OFF	OFF	OFF	OFF	Latest value																																																																																																																																									
ON	OFF	OFF	OFF	ON	B11-4																																																																																																																																									
ON	OFF	OFF	ON	OFF	B11-5																																																																																																																																									
ON	OFF	ON	OFF	OFF	B11-6																																																																																																																																									
ON	ON	OFF	OFF	OFF	B11-7																																																																																																																																									
1	Program frequency (speed) –1	%	10.00	0.00	100.00																																																																																																																																									
2	Program frequency (speed) –2	%	10.00	0.00	100.00																																																																																																																																									
3	Program frequency (speed) –3	%	10.00	0.00	100.00																																																																																																																																									
4	Program frequency (speed) –4	%	10.00	0.00	100.00																																																																																																																																									
5	Program frequency (speed) –5	%	10.00	0.00	100.00																																																																																																																																									
6	Program frequency (speed) –6	%	10.00	0.00	100.00																																																																																																																																									
7	Program frequency (speed) –7	%	10.00	0.00	100.00																																																																																																																																									
8	Selection mode setting		1.	1.	2.	= 1 : Binary mode = 2 : Direct select mode Select the program frequency setting (B11) and program ramp (B41, B42) selection mode.	○																																																																																																																																							

## 6. Control Functions and Parameter Settings

### Block-B parameters (Extended function constants) list

No.	Parameter	Unit	Default	Min.	Max.	Function	Application			
							ST	V/f	VEC	PM
<b>B13 – Local setting</b>										
0	Torque setting	%	100.0	-300.0	300.0	Torque setting from the keypad			<input type="radio"/>	<input type="radio"/>
1	Torque ratio 1 setting		1.000	0.001	5.000				<input type="radio"/>	<input type="radio"/>
2	Torque bias 1 setting	%	0.0	-300.0	300.0				<input type="radio"/>	<input type="radio"/>
3	Torque ratio 2 setting		1.000	-5.000	5.000				<input type="radio"/>	<input type="radio"/>
4	Double rating speed ratio setting	%	100.0	0.1	100.0	This sets the torque limit reduction pattern changeover point. Set as a percentage in respect to the base speed.			<input type="radio"/>	<input type="radio"/>
5	Drooping setting	%	0.00	0.00	20.00	By adjusting this parameter, the motor torque/speed characteristics can be achieved.			<input type="radio"/>	<input type="radio"/>
6	ASR gain compensation in constant power range	%	100.0	0.0	150.0	This sets the ASR P gain compensation value at the max. speed. By adjusting this parameter, the ASR P gain can be compensated in the constant power range. If ASR hunting occurs in the constant power range, (with sensor-less vector control) set a smaller value.			<input type="radio"/>	<input type="radio"/>
7	ACR gain compensation in constant power range	%	100.0	0.0	150.0	This sets the ACR P gain compensation value at the max. speed. By adjusting this parameter, the ACR P gain can be compensated in the constant power range.			<input type="radio"/>	<input type="radio"/>
<b>B14 – ASR dead band setting</b>										
0	ASR dead band setting	%	0.0	0.0	100.0	The non-sensitive range of the ASR input is set.			<input type="radio"/>	<input type="radio"/>
<b>B15 – Machine time constant setting 2</b>										
0	Machine time constant 2	ms	1000.	10.	20000.	This is the time to accelerate the motor + load to the base speed at the motor rated torque. This is valid when the sequence input machine time constant changeover is ON (MCH = ON).			<input type="radio"/>	<input type="radio"/>
<b>B17 – V/f middle point</b>										
0	Frequency 2	Hz	0.0	0.0	Max.freq.	These parameters should be set: Base frequency $\geq$ B17-0 $\geq$ B17-2 B17-1 $\geq$ B17-3			<input type="radio"/>	
1	Voltage 2	%	0.0	0.0	100.0				<input type="radio"/>	
2	Frequency 1	Hz	0.0	0.0	Max.freq.				<input type="radio"/>	
3	Voltage 1	%	0.0	0.0	100.0				<input type="radio"/>	
<b>B18 – Over current limit</b>										
0	Over current limit	%	150.	100.	300.				<input type="radio"/>	
1	Regenerative current limit	%	10.	5.	300.	Set to 10% if there is not DBR.			<input type="radio"/>	
2	Torque stabilisation gain		1.00	0.	4.00	Increase if the motor vibrates.			<input type="radio"/>	
3	Over current limit function gain		0.25	0.	2.00	Decrease if current hunting occurs.			<input type="radio"/>	
4	Current stabilisation gain		0.25	0.	2.00				<input type="radio"/>	
5	Over current break-down prevention gain		1.00	0.	2.00				<input type="radio"/>	
6	Over current stall prevention time constant		100.	10.	1001.	P control will be applied if 1001 is set.			<input type="radio"/>	
<b>B19 – Automatic tuning function</b>										
0	Automatic tuning selection		0.	0.	5	The automatic tuning mode is selected. 0: Disabled (Normal running mode) 1: Basic tuning for V/f Control 2: Extended tuning for V/f Control 3: Basic tuning for Vector Control 4: Extended tuning for Vector Control 5: Load mode (check chapter 3-6-2)			<input type="radio"/>	<input type="radio"/>

## 6. Control Functions and Parameter Settings

### Block-B parameters (Extended function constants) list

No.	Parameter	Unit	Default	Min.	Max.	Function	Application																																					
							ST	V/f	VEC	PM																																		
<b>B19 – Automatic tuning function (continues from previous page)</b>																																												
1	Initial proportional compensation gain	%	100.	0.	500.	Autotuning initial settings. If Autotuning is completed incorrectly change initial settings and try again. Increase these values in 50% steps	<input type="radio"/>	<input type="radio"/>	<input type="radio"/>	<input type="radio"/>																																		
2	Initial time constant compensation gain	%	100.	0.	500.		<input type="radio"/>	<input type="radio"/>	<input type="radio"/>	<input type="radio"/>																																		
<b>B20 – Output rating (Dual drive)</b>																																												
0	Max./base frequency simple setting		1.	0	9	Select the output frequency rating from the following table.	<input type="radio"/>																																					
		<table border="1" style="display: inline-table; margin-right: 20px;"> <thead> <tr> <th>Value</th> <th>Ftrq (Hz)</th> <th>Fmax (Hz)</th> </tr> </thead> <tbody> <tr> <td>0</td> <td colspan="2">Free setting on B00-4 and B00-5</td> </tr> <tr> <td>1</td> <td>50</td> <td>50</td> </tr> <tr> <td>2</td> <td>60</td> <td>60</td> </tr> <tr> <td>3</td> <td>50</td> <td>60</td> </tr> <tr> <td>4</td> <td></td> <td>75</td> </tr> <tr> <td>5</td> <td></td> <td>100</td> </tr> </tbody> </table> <table border="1" style="display: inline-table;"> <thead> <tr> <th>Value</th> <th>Ftrq (Hz)</th> <th>Fmax (Hz)</th> </tr> </thead> <tbody> <tr> <td>6</td> <td>60</td> <td>70</td> </tr> <tr> <td>7</td> <td></td> <td>80</td> </tr> <tr> <td>8</td> <td></td> <td>90</td> </tr> <tr> <td>9</td> <td></td> <td>120</td> </tr> </tbody> </table>			Value	Ftrq (Hz)	Fmax (Hz)	0	Free setting on B00-4 and B00-5		1	50	50	2	60	60	3	50	60	4		75	5		100	Value	Ftrq (Hz)	Fmax (Hz)	6	60	70	7		80	8		90	9		120				
Value	Ftrq (Hz)	Fmax (Hz)																																										
0	Free setting on B00-4 and B00-5																																											
1	50	50																																										
2	60	60																																										
3	50	60																																										
4		75																																										
5		100																																										
Value	Ftrq (Hz)	Fmax (Hz)																																										
6	60	70																																										
7		80																																										
8		90																																										
9		120																																										
1	Rated output voltage	V	200 /400.	40.	480.	The Automatic Voltage regulator DC-AVR, is always enabled, so the set voltage is attained at the base frequency. This is the rated motor voltage, which can not be set to a larger value than the input voltage set in B00-0.	<input type="radio"/>																																					
2	Max. frequency	Hz	50.0	3.0	440.0	When "B20-0" is a value other than 0, these values will be rewritten with the data set in B20-0	<input type="radio"/>																																					
3	Base frequency	Hz	50.0	1.0	440.0		<input type="radio"/>																																					
4	Motor rated current	A	Inverter rating	Inverter rating × 0.3	Inverter rating	The overcurrent limit, OLT, current % display and meter output. are related to this setting	<input type="radio"/>																																					
5	Carrier frequency (Drives up to U2KN37K0 or U2KX45K0)		17.0	1.0	21.0	The noise can be lowered by changing the PWM carrier frequency and control method, which affects to the sound generated from the motor. This can be changed while running. <b>1.0-15.0:</b> Monotone sound method (Carrier frequency: 1.0 to 15.0kHz) <b>15.1-18.0:</b> Soft sound method 1 (Carrier frequency: 2.1 to 5.0kHz) <b>18.1 to 21.0:</b> Soft sound method 2 (Carrier frequency: 2.1 to 5.0kHz)	<input type="radio"/>																																					
	Carrier frequency (Drives larger than U2KX45K0)		10.0	1.0	14.0	<b>1.0-8.0:</b> Monotone sound method (Carrier frequency: 1.0 to 15.0kHz) <b>8.1-11.0:</b> Soft sound method 1 (Carrier frequency: 2.1 to 5.0kHz) <b>11.1 to 14.0:</b> Soft sound method 2 (Carrier frequency: 2.1 to 5.0kHz)	<input type="radio"/>																																					
<b>B21 – Frequency setting (Dual Drive)</b>																																												
0	Local frequency setting	Hz	10.00	0.10	Max.fre- quency	This is the frequency set from the operation panel.	<input type="radio"/>																																					
1	Frequency setting for jogging	Hz	5.00	0.10	Max.fre- quency	This is the frequency setting for jogging.	<input type="radio"/>																																					
<b>B22 – Acceleration/deceleration time (Dual Drive)</b>																																												
0	Acceleration ramp time-1	sec	10.0	0.1	6000.0	This is the time to reach the max. frequency or max. speed from 0	<input type="radio"/>																																					
1	Deceleration ramp time-1	sec	20.0	0.1	6000.0	This value can be set x0.1 or x10 units by setting the parameter B10-5	<input type="radio"/>																																					
2	Acceleration ramp time for jogging	sec	5.0	0.1	6000.0	This is the acceleration/deceleration time value when the JOG sequence (F JOG, R JOG) is ON. This value can be set x0.1 or x10 units by setting the parameter B10-5.	<input type="radio"/>																																					
3	Deceleration ramp time for jogging	sec	5.0	0.1	6000.0		<input type="radio"/>																																					

## 6. Control Functions and Parameter Settings

### Block-B parameters (Extended function constants) list

No.	Parameter	Unit	Default	Min.	Max.	Function	Application			
							ST	V/f	VEC	PM
<b>B23 – Torque Boost (Dual Drive)</b>										
0	Manual torque boost voltage	%	Inverter rating	0.0	20.0	This is the boost voltage at 0Hz.	<input type="checkbox"/>			
1	Square reduction torque setting	%	0.0	0.0	25.0	This is the reduced voltage at half of base frequency.	<input type="checkbox"/>			
<b>B24 – DC Brake (Dual Drive)</b>										
0	DC braking voltage	%	Inverter rating	0.1	20.0		<input type="checkbox"/>			
1	DC braking time	sec	2.0	0.0	20.0		<input type="checkbox"/>			
<b>B25 – Overcurrent limit (Dual Drive)</b>										
0	Overcurrent limit	%	150.	50.	300.		<input type="checkbox"/>			
1	Regenerative current limit	%	10.	5.	300.	Set to 10% if there is not DBR.	<input type="checkbox"/>			
2	Torque stabilisation gain		1.00	0.	4.00	Increase if the motor vibrates.	<input type="checkbox"/>			
<b>B30 – Speed control extended function</b>										
0	Load torque observer gain		0.	0.	200.	This is the gain for the load torque observer. To increase the response characteristic from an external disturbance, set a large gain. Note that if the gain is set too high, the output torque could start hunting. When set to zero, the load torque observer will not function.			<input type="checkbox"/>	<input type="checkbox"/>
1	Model machine time constant	ms	500.	10.	20000.	Set the model machine time constant used by the load torque observer.			<input type="checkbox"/>	<input type="checkbox"/>
2	ASR proportional change rate limit	%	50.0	1.0	400.0	If the speed setting value or motor speed change suddenly, this will prevent the ASR's, P response, from suddenly changing.			<input type="checkbox"/>	<input type="checkbox"/>
3	LPF time constant for Speed setting	ms	0.	0.	1000.	This filter is used to suppress overshooting, by setting a time constant equivalent to the speed response.			<input type="checkbox"/>	<input type="checkbox"/>
4	LPF time constant for Speed detection	ms	2.	0.	1000.	This filter is used to suppress the noise in speed detection.			<input type="checkbox"/>	<input type="checkbox"/>
5	LPF time constant for Speed detection ASR	ms	5.	0.	1000.	This filter is used for the speed detection in the ASR.			<input type="checkbox"/>	<input type="checkbox"/>
6	LPF time constant for flux compensation	ms	20.	0.	1000.	This filter affects the speed detection used in constant power or iron loss compensations, etc.			<input type="checkbox"/>	<input type="checkbox"/>
7	LPF time constant for actual Torque setting	ms	0.	0.	1000.	Set the low path filter time constant used for the torque current command.			<input type="checkbox"/>	<input type="checkbox"/>
8	LPF time constant for drooping	ms	100.	0.	1000.	Set the low path filter time constant used for drooping value input into the speed regulator.			<input type="checkbox"/>	<input type="checkbox"/>

## 6. Control Functions and Parameter Settings

### Block-B parameters (Extended function constants) list

No.	Parameter	Unit	Default	Min.	Max.	Function	Application			
							ST	V/f	VEC	PM
<b>B31 – Sensor-less control function</b>										
0	Flux observer gain		1.20	0.50	2.00	This is the gain for flux observer feedback. If in the high-speed operation range, occurs hunting at the estimated speed, adjust within the range of 1.2 to 0.9.			○	
1	Speed estimated proportional gain	%	0.00	0.00	100.0	This is the proportional gain for the adaptive speed estimation algorithm. To increase the speed estimation response, set a large value. Note that if the value is too high, the speed estimation value will hunt.			○	
2	Speed estimated integral gain	%	1.00	0.00	100.0	This is the integral gain for the adaptive speed estimation algorithm. To increase the speed estimation response, set a large value. Note that if the value is too high, the speed estimation value will hunt.			○	
3	Regenerative compensation torque limit 1	%	10.0	0.1	100.0	The regenerative torque limit can be changed in the low speed area. The shaded area shows the operating range. If the operation is unstable at a point, set the compensation limits to keep the unstable region out the shaded area			○	
4	Regenerative compensation torque limit 2	%	20.0	0.1	100.0					
5	Regenerative compensation low-speed area setting 1	%	10.0	0.1	100.0					
6	Regenerative compensation low-speed area setting 2	%	20.0	0.1	100.0					

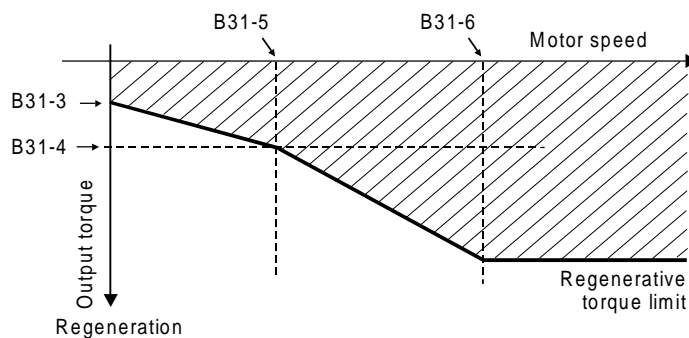

**Regenerative compensation  
(B31-3, 4, 5, 6)**

## 6. Control Functions and Parameter Settings

### Block-B parameters (Extended function constants) list

No.	Parameter	Unit	Default	Min.	Max.	Function	Application			
							ST	V/f	VEC	PM
<b>B32 – Vector control compensation selection</b>										
0	High speed flux control selection		1.	1.	2.	1: Disable 2: Enable This is the control selection for magnetising the secondary flux to a high speed when starting operation. Select this to increase the motor speed even slightly when starting operation.			○	
1	Temperature compensation selection		1.	1.	2.	1: Disable 2: Enable This is to compensate fluctuation of R1, R2 motor constants caused by changes in the motor's temperature. Useful if high torque accuracy is required when (C30-0 = 4), or if high speed accuracy is required in sensor-less operation (C30-0 = 3),			○	○
2	Voltage saturation compensation selection		2.	1.	2.	1: Disable 2: Enable This function is useful If the output voltage is larger than the voltage that can be output by the inverter, or when raising the output voltage to near the input voltage, or when the input voltage changes, limiting the exciting current to prevent the current or torque instability.  If there is voltage saturation, a high ripple in the torque will occur. In this case, lower the B01-9 setting to avoid this.			○	○
3	Iron loss compensation selection		1.	1.	2.	1: Disable 2: Enable This compensates the torque error caused by iron loss. The iron loss resistance value (B02-8, 9) must be set.			○	
4	ACR voltage model FF selection		2.	1.	2.	1: Disable 2: Enable The voltage fluctuation caused by the leakage inductance is feed forward controlled. The current regulator (ACR) response will be increased. Select this if the current hunts in the high-speed operation range during sensor-less control.			○	○

## 6. Control Functions and Parameter Settings

### Block-B parameters (Extended function constants) list

No.	Parameter	Unit	Default	Min.	Max.	Function	Application			
							ST	V/f	VEC	PM
<b>B33 – M fluctuation compensation table reference speed</b>										
0	Table reference speed 0	min <sup>-1</sup>	200	100.	7200.	This is the reference speed table . These values will be affected by the compensation (B34) block.				○
1	Table reference speed 1	min <sup>-1</sup>	400	100.	7200.					
2	Table reference speed 2	min <sup>-1</sup>	600	100.	7200.					
3	Table reference speed 3	min <sup>-1</sup>	800	100.	7200.					
4	Table reference speed 4	min <sup>-1</sup>	1000	100.	7200.					
5	Table reference speed 5	min <sup>-1</sup>	1200	100.	7200.					
6	Table reference speed 6	min <sup>-1</sup>	1400	100.	7200.					
7	Table reference speed 7	min <sup>-1</sup>	1600	100.	7200.					
<b>B34 – M fluctuation compensation</b>										
0	M fluctuation compensation coefficient 0	%	100.0	50.0	150.0	This is adjusted with the automatic tuning mode 4 (B19-0 = 4).				
1	M fluctuation compensation coefficient 1	%	100.0	50.0	150.0					
2	M fluctuation compensation coefficient 2	%	100.0	50.0	150.0	This compensates the exciting inductance fluctuation according to the B33 reference speed values. Set the compensation coefficients that the output voltage is constant during no-load operation through the entire operation range.				
3	M fluctuation compensation coefficient 3	%	100.0	50.0	150.0					
4	M fluctuation compensation coefficient 4	%	100.0	50.0	150.0					○
5	M fluctuation compensation coefficient 5	%	100.0	50.0	150.0					
6	M fluctuation compensation coefficient 6	%	100.0	50.0	150.0					
7	M fluctuation compensation coefficient 7	%	100.0	50.0	150.0					
<b>B35 – Constant Voltage control (PM)</b>										
0	Demagnetizing control operation voltage range	%	10.0	50.0	100.0	% of rated voltage				○
1	Demagnetizing current limit value	%	50.0	10.0	200.0	Ratio of rated voltage				○
2	Demagnetizing proportional gain	times	0.10	0.01	99.99					○
3	Demagnetizing integral gain	ms	10.	2.	1000.					○
4	Flux temperature fluctuation compensation range	%	0.0	0.0	50.0					○
5	Flux temperature fluctuation compensation time constant	%	1000.	1.	9999.					○
<b>B36 – Demagnetizing current table (PM)</b>										
0	Demagnetizing current table 0	%	0.0	0.0	100.0	Demagnetising current table (at torque command 25%)				○
1	Demagnetizing current table 1	%	0.0	0.0	100.0	(at torque command 50%)				○
2	Demagnetizing current table 2	%	0.0	0.0	100.0	(at torque command 75%)				○
3	Demagnetizing current table 3	%	0.0	0.0	100.0	(at torque command 100%)				○
4	Demagnetizing current table 4	%	0.0	0.0	100.0	(at torque command 150%)				○

## 6. Control Functions and Parameter Settings

### Block-B parameters (S/W option constants) list

No.	Parameter	Unit	Default	Min.	Max.	Function	Application																																																																																																																																					
							ST	V/f	VEC	PM																																																																																																																																		
<b>B40 – Software option function</b>																																																																																																																																												
0	Function selection – 1		1	1.	4	= 1: Following functions are not used = 2: Program ramp function = 3: Pattern Run = 4: Traverse run	○																																																																																																																																					
1	Function selection – 2		1	1.	3	= 1: Following functions are not used = 2: PID = 3: PID, multi-pump control	○																																																																																																																																					
<b>B41 – Program ramp – acceleration</b>																																																																																																																																												
0	Acceleration time – 0	sec	10.0	0.1	6000.0	Select as follows with S0, S1, S2, S3 and SE.	○																																																																																																																																					
1	– 1	sec	10.0	0.1	6000.0																																																																																																																																							
2	– 2	sec	10.0	0.1	6000.0																																																																																																																																							
3	– 3	sec	10.0	0.1	6000.0																																																																																																																																							
4	– 4	sec	10.0	0.1	6000.0																																																																																																																																							
5	– 5	sec	10.0	0.1	6000.0																																																																																																																																							
6	– 6	sec	10.0	0.1	6000.0																																																																																																																																							
7	– 7	sec	10.0	0.1	6000.0																																																																																																																																							
<b>B42 – Program ramp – deceleration</b>																																																																																																																																												
0	Deceleration time – 0	sec	20.0	0.1	6000.0		○																																																																																																																																					
1	– 1	sec	20.0	0.1	6000.0																																																																																																																																							
2	– 2	sec	20.0	0.1	6000.0																																																																																																																																							
3	– 3	sec	20.0	0.1	6000.0																																																																																																																																							
4	– 4	sec	20.0	0.1	6000.0																																																																																																																																							
5	– 5	sec	20.0	0.1	6000.0																																																																																																																																							
6	– 6	sec	20.0	0.1	6000.0																																																																																																																																							
7	– 7	sec	20.0	0.1	6000.0																																																																																																																																							
<p>The binary mode or direct input mode is selected with B11-8.</p> <div style="display: flex; justify-content: space-around;"> <div style="width: 45%;"> <p><b>(1) For Binary mode selection</b></p> <table border="1" style="width: 100%; border-collapse: collapse; text-align: center;"> <thead> <tr> <th colspan="5">Sequence Command</th> <th rowspan="2">Selected ramp time</th> </tr> <tr> <th>SE</th> <th>S3</th> <th>S2</th> <th>S1</th> <th>S0</th> </tr> </thead> <tbody> <tr> <td></td> <td></td> <td>OFF</td> <td>OFF</td> <td>OFF</td> <td>B41-0 B42-0</td> </tr> <tr> <td></td> <td></td> <td>OFF</td> <td>OFF</td> <td>ON</td> <td>B41-1 B42-1</td> </tr> <tr> <td></td> <td></td> <td>OFF</td> <td>ON</td> <td>OFF</td> <td>B41-2 B42-2</td> </tr> <tr> <td></td> <td></td> <td>OFF</td> <td>ON</td> <td>ON</td> <td>B41-3 B42-3</td> </tr> <tr> <td></td> <td></td> <td>ON</td> <td>OFF</td> <td>OFF</td> <td>B41-4 B42-4</td> </tr> <tr> <td></td> <td></td> <td>ON</td> <td>OFF</td> <td>ON</td> <td>B41-5 B42-5</td> </tr> <tr> <td></td> <td></td> <td>ON</td> <td>ON</td> <td>OFF</td> <td>B41-6 B42-6</td> </tr> <tr> <td></td> <td></td> <td>ON</td> <td>ON</td> <td>ON</td> <td>B41-7 B42-7</td> </tr> </tbody> </table> <p>SE and S3 are not used</p> </div> <div style="width: 45%;"> <p><b>(1) For Direct mode selection</b></p> <table border="1" style="width: 100%; border-collapse: collapse; text-align: center;"> <thead> <tr> <th colspan="5">Sequence Command</th> <th rowspan="2">Selected ramp time</th> </tr> <tr> <th>SE</th> <th>S3</th> <th>S2</th> <th>S1</th> <th>S0</th> </tr> </thead> <tbody> <tr> <td>OFF</td> <td>OFF</td> <td>OFF</td> <td>OFF</td> <td>OFF</td> <td>Latest values</td> </tr> <tr> <td>OFF</td> <td>OFF</td> <td>OFF</td> <td>OFF</td> <td>ON</td> <td>B41-0 B42-0</td> </tr> <tr> <td>OFF</td> <td>OFF</td> <td>OFF</td> <td>ON</td> <td>OFF</td> <td>B41-1 B42-1</td> </tr> <tr> <td>OFF</td> <td>OFF</td> <td>ON</td> <td>OFF</td> <td>OFF</td> <td>B41-2 B42-2</td> </tr> <tr> <td>OFF</td> <td>ON</td> <td>OFF</td> <td>OFF</td> <td>OFF</td> <td>B41-3 B42-3</td> </tr> <tr> <td>ON</td> <td>OFF</td> <td>OFF</td> <td>OFF</td> <td>OFF</td> <td>Latest values</td> </tr> <tr> <td>ON</td> <td>OFF</td> <td>OFF</td> <td>OFF</td> <td>ON</td> <td>B41-4 B42-4</td> </tr> <tr> <td>ON</td> <td>OFF</td> <td>OFF</td> <td>ON</td> <td>OFF</td> <td>B41-5 B42-5</td> </tr> <tr> <td>ON</td> <td>OFF</td> <td>ON</td> <td>OFF</td> <td>OFF</td> <td>B41-6 B42-6</td> </tr> <tr> <td>ON</td> <td>ON</td> <td>OFF</td> <td>OFF</td> <td>OFF</td> <td>B41-7 B42-7</td> </tr> </tbody> </table> <p>When S0 to S3 are all OFF the latest ramp time set value is hold. After power ON the latest value is cleared to "0"</p> </div> </div>											Sequence Command					Selected ramp time	SE	S3	S2	S1	S0			OFF	OFF	OFF	B41-0 B42-0			OFF	OFF	ON	B41-1 B42-1			OFF	ON	OFF	B41-2 B42-2			OFF	ON	ON	B41-3 B42-3			ON	OFF	OFF	B41-4 B42-4			ON	OFF	ON	B41-5 B42-5			ON	ON	OFF	B41-6 B42-6			ON	ON	ON	B41-7 B42-7	Sequence Command					Selected ramp time	SE	S3	S2	S1	S0	OFF	OFF	OFF	OFF	OFF	Latest values	OFF	OFF	OFF	OFF	ON	B41-0 B42-0	OFF	OFF	OFF	ON	OFF	B41-1 B42-1	OFF	OFF	ON	OFF	OFF	B41-2 B42-2	OFF	ON	OFF	OFF	OFF	B41-3 B42-3	ON	OFF	OFF	OFF	OFF	Latest values	ON	OFF	OFF	OFF	ON	B41-4 B42-4	ON	OFF	OFF	ON	OFF	B41-5 B42-5	ON	OFF	ON	OFF	OFF	B41-6 B42-6	ON	ON	OFF	OFF	OFF	B41-7 B42-7
Sequence Command					Selected ramp time																																																																																																																																							
SE	S3	S2	S1	S0																																																																																																																																								
		OFF	OFF	OFF	B41-0 B42-0																																																																																																																																							
		OFF	OFF	ON	B41-1 B42-1																																																																																																																																							
		OFF	ON	OFF	B41-2 B42-2																																																																																																																																							
		OFF	ON	ON	B41-3 B42-3																																																																																																																																							
		ON	OFF	OFF	B41-4 B42-4																																																																																																																																							
		ON	OFF	ON	B41-5 B42-5																																																																																																																																							
		ON	ON	OFF	B41-6 B42-6																																																																																																																																							
		ON	ON	ON	B41-7 B42-7																																																																																																																																							
Sequence Command					Selected ramp time																																																																																																																																							
SE	S3	S2	S1	S0																																																																																																																																								
OFF	OFF	OFF	OFF	OFF	Latest values																																																																																																																																							
OFF	OFF	OFF	OFF	ON	B41-0 B42-0																																																																																																																																							
OFF	OFF	OFF	ON	OFF	B41-1 B42-1																																																																																																																																							
OFF	OFF	ON	OFF	OFF	B41-2 B42-2																																																																																																																																							
OFF	ON	OFF	OFF	OFF	B41-3 B42-3																																																																																																																																							
ON	OFF	OFF	OFF	OFF	Latest values																																																																																																																																							
ON	OFF	OFF	OFF	ON	B41-4 B42-4																																																																																																																																							
ON	OFF	OFF	ON	OFF	B41-5 B42-5																																																																																																																																							
ON	OFF	ON	OFF	OFF	B41-6 B42-6																																																																																																																																							
ON	ON	OFF	OFF	OFF	B41-7 B42-7																																																																																																																																							

## 6. Control Functions and Parameter Settings

### Block-B parameters (S/W option constants) list

No.	Parameter	Unit	Default	Min.	Max.	Function	Application			
							ST	V/f	VEC	PM
<b>B43 – PID Control</b>										
0	Proportional Gain		1.00	0.01	10.00		○			
1	Integral time constant	sec	10.0	0.0	30.0		○			
2	Differential time constant	sec	0.000	0.000	1.000		○			
3	Upper limit	%	100.	50.	100.	The maximum frequency (B00-4) and maximum speed (B01-4) are 100%	○			
4	Lower limit	%	0.	0.	50.		○			
<b>B44 – Multi-pump control</b>										
0	No. of controlled pumps	units	3.	1.	5.	Set the No of pumps to be ON / OFF controlled	○			
1	Holding time	sec	60.	3.	3600.	When the PID output reaches either Lower or Upper limit longer that the time set, one of the pumps is switch OFF or ON	○			
2	Continuous operation limit time	Hrs	8.	2.	48.	This is maximum time allowed for running a pump. The pumps will rotate so the operating time of each pump is equal.	○			
3	Changeover time	sec	3.	1.	120.	This is the OFF/ON transition time between the pumps which are rotated.	○			
<b>B45 – Traverse run</b>										
0	Centre frequency (FH)	%	20.00	5.00	100.00		○			
1	Amplitude (A)	%	10.0	0.1	20.0	Set (A/FH) x 100	○			
2	Drop (D)	%	0.0	0.0	50.0	Set (D/A) x 100	○			
3	Acceleration time (B)	sec	10.0	0.5	60.0		○			
4	Deceleration time (C)	sec	10.0	0.5	60.0		○			
5	Deviated traverse (X)	%	10.0	0.0	20.0	Set (X/FH) x 100	○			
6	Deviated traverse (Y)	%	10.0	0.0	20.0	Set (Y/FH) x 100	○			
<b>B50 – Pattern run step-0 (Automatic run)</b>										
0	Mode)		0.	0.	2.	= 0: Stop	○			
1	Frequency (speed)	%	10.00	0.00	100.00	= 1: Forward run				
2	Time	sec	1.0	0.1	6000.0	= 2: Reverse run				
<b>B51 – Pattern run step-1 (Automatic run)</b>										
0	Mode)		0.	0.	2.	= 0: Stop	○			
1	Frequency (speed)	%	10.00	0.00	100.00	= 1: Forward run				
2	Time	sec	1.0	0.1	6000.0	= 2: Reverse run				
<b>B52 – Pattern run step-2 (Automatic run)</b>										
0	Mode)		0.	0.	2.	= 0: Stop	○			
1	Frequency (speed)	%	10.00	0.00	100.00	= 1: Forward run				
2	Time	sec	1.0	0.1	6000.0	= 2: Reverse run = 3: Return				
<b>B53 – Pattern run step-3 (Automatic run)</b>										
0	Mode)		0.	0.	2.	= 0: Stop	○			
1	Frequency (speed)	%	10.00	0.00	100.00	= 1: Forward run				
2	Time	sec	1.0	0.1	6000.0	= 2: Reverse run				
3	Return destination step		0.	0.	2.	= 3: Return				
<b>B54 – Pattern run step-4 (Automatic run)</b>										
0	Mode)		0.	0.	2.	= 0: Stop	○			
1	Frequency (speed)	%	10.00	0.00	100.00	= 1: Forward run				
2	Time	sec	1.0	0.1	6000.0	= 2: Reverse run				
3	Return destination step		0.	0.	3.	= 3: Return				

## 6. Control Functions and Parameter Settings

### Block-B parameters (S/W option constants) list

No.	Parameter	Unit	Default	Min.	Max.	Function	Application			
							ST	V/f	VEC	PM
<b>B55 – Pattern run step-5 (Automatic run)</b>										
0	Mode)		0.	0.	2.	= 0: Stop				
1	Frequency (speed)	%	10.00	0.00	100.00	= 1: Forward run	○			
2	Time	sec	1.0	0.1	6000.0	= 2: Reverse run				
3	Return destination step		0.	0.	4.	= 3: Return				
<b>B56 – Pattern run step-6 (Automatic run)</b>										
0	Mode)		0.	0.	2.	= 0: Stop				
1	Frequency (speed)	%	10.00	0.00	100.00	= 1: Forward run	○			
2	Time	sec	1.0	0.1	6000.0	= 2: Reverse run				
3	Return destination step		0.	0.	5.	= 3: Return				
<b>B57 – Pattern run step-7 (Automatic run)</b>										
0	Mode)		0.	0.	2.	= 0: Stop				
1	Frequency (speed)	%	10.00	0.00	100.00	= 1: Forward run	○			
2	Time	sec	1.0	0.1	6000.0	= 2: Reverse run				
3	Return destination step		0.	0.	6.	= 3: Return				
<b>B58 – Pattern run step-8 (Automatic run)</b>										
0	Mode)		0.	0.	2.	= 0: Stop				
1	Frequency (speed)	%	10.00	0.00	100.00	= 1: Forward run	○			
2	Time	sec	1.0	0.1	6000.0	= 2: Reverse run				
3	Return destination step		0.	0.	7.	= 3: Return				
<b>B59 – Pattern run step-8 (Automatic run)</b>										
0	Mode)		0.	0.	2.	= 0: Stop				
1	Frequency (speed)	%	10.00	0.00	100.00	= 1: Forward run	○			
2	Time	sec	1.0	0.1	6000.0	= 2: Reverse run				
3	Return destination step		0.	0.	8.	= 3: Return				

## 6. Control Functions and Parameter Settings

### 6-4 Block-C parameters

The Block-C parameters are divided into the basic functions, extended functions and hardware option functions.

**Block-C parameters (Basic function constants) list**

No.	Parameter	Unit	Default	Min.	Max.	Function	Application			
							ST	V/f	VEC	PM
<b>C00 – Control methods</b>										
0	Run command method		1.	1.	3.	Run command method is set. = 1 : F·RUN, R·RUN = 2 : RUN, REV = 3 : Pulse (by Push-buttons) (Pulse inputs for F·RUN and R·RUN)	○			
1	RUN/STOP methods		2.	1.	2.	Set the stopping method for RUN operation. = 1 : Coast to stop = 2 : Ramp down to stop	○			
2	Jog stop method		2.	1.	2.	Set the stopping method for JOG operation. = 1 : Coast to stop = 2 : Ramp down to stop	○			
3	Emergency stop (EMS) input logic		1.	1.	2.	Emergency stop input logic is set. = 1 : Close to stop = 2 : Open to stop	○			
4	Emergency stop (EMS) mode		1.	1.	3.	Set the stopping method for the emergency stop. = 1 : Coast to stop without a fault output = 2 : Coast to stop with a fault output = 3 : Ramp down to stop	○			
5	Control source switchover method (J1 setting)		1.	1.	2.	Set whether to validate the remote operation sequence for the local operation mode. Fig 5.2 = 1 : Disables = 2 : Enables	○			
6	Control source switchover method (J2 setting)		1.	1.	2.	Select the No. of auxiliary operation sequence input points when the COP command is ON. Fig 5.2 = 1 : Terminal block input = 2 : Serial input	○			
7	Run contact output condition selection		1.	1.	2.	The conditions for turning the sequence RUN output ON are set. = 1 : ON at pre-excitation = 2 : OFF at pre-excitation	○			
<b>C01 – Start/stop frequency</b>										
0	Start frequency	Hz	1.0	0.1	60.0			○		
1	Stop frequency (DC brake start)	Hz	1.0	0.1	60.0			○		

## 6. Control Functions and Parameter Settings

### Block-C parameters (Basic function constants) list

No.	Parameter	Unit	Default	Min.	Max.	Function	Application			
							ST	V/f	VEC	PM
<b>C02 – Various setting input selection</b>										
0	Speed setting input selection		4.	1.	4.	= 1 : Analog fixed = 2 : Serial/parallel fixed = 3 : Panel fixed = 4 : Sequence	○			
1	Traverse centre frequency input selection		2.	1.	3.	= 1 : Analog fixed = 2 : Panel fixed = 3 : Sequence	○			
2	Torque setting input selection		3.	1.	4.	= 1 : Analog fixed = 3 : Panel fixed = 2 : Serial fixed = 4 : Sequence			○	○
3	Torque ratio 1 setting selection		2.	1.	3.	= 1 : Serial fixed = 2 : Panel fixed = 3 : Sequence			○	○
4	Torque bias 1 setting input selection		3.	1.	4.	= 1 : Analog fixed = 3 : Panel fixed = 2 : Serial fixed = 4 : Sequence			○	○
5	Torque ratio 2 setting input selection		2.	1.	3.	= 1 : Serial fixed = 2 : Panel fixed = 3 : Sequence			○	○
6	Drive/regenerative torque limit input selection		3.	1.	3.	= 1 : Analog fixed = 2 : Serial fixed = 3 : Sequence			○	○
7	ASR response input selection		2.	1.	3.	= 1 : Serial fixed = 2 : Panel fixed = 3 : Sequence			○	○
8	Machine time constant points selection		2.	1.	3.	= 1 : Serial fixed = 2 : Panel fixed = 3 : Sequence			○	○

6. Control Functions and Parameter Settings

Block-C parameters (Basic function constants) list

No.	Parameter	Unit	Default	Min.	Max.	Function	Application																																							
							ST	V/f	VEC	PM																																				
<b>C03 – Sequence input function – 1</b>																																														
0	R-RUN (Reverse run)		1.	0.	16.	<table border="1"> <thead> <tr> <th>Value</th> <th>Input terminal (1)</th> </tr> </thead> <tbody> <tr> <td>0</td> <td>OFF fixed</td> </tr> <tr> <td>1</td> <td>PSI1</td> </tr> <tr> <td>2</td> <td>PSI2</td> </tr> <tr> <td>3</td> <td>PSI3</td> </tr> <tr> <td>4</td> <td>PSI4</td> </tr> <tr> <td>5</td> <td>PSI5</td> </tr> <tr> <td>6</td> <td>PSI6 Optional</td> </tr> <tr> <td>7</td> <td>PSI7 Optional</td> </tr> <tr> <td>8</td> <td>PSI8 Optional</td> </tr> <tr> <td>9</td> <td>PSI9 Optional</td> </tr> <tr> <td>10</td> <td>(PL0) Program outputs</td> </tr> <tr> <td>11</td> <td>(PL1) (For future use)</td> </tr> <tr> <td>12</td> <td>(PL2)</td> </tr> <tr> <td>13</td> <td>(PL3)</td> </tr> <tr> <td>14</td> <td>EMS</td> </tr> <tr> <td>15</td> <td>FRUN</td> </tr> <tr> <td>16</td> <td>ON Fixed</td> </tr> </tbody> </table>	Value	Input terminal (1)	0	OFF fixed	1	PSI1	2	PSI2	3	PSI3	4	PSI4	5	PSI5	6	PSI6 Optional	7	PSI7 Optional	8	PSI8 Optional	9	PSI9 Optional	10	(PL0) Program outputs	11	(PL1) (For future use)	12	(PL2)	13	(PL3)	14	EMS	15	FRUN	16	ON Fixed	<input type="checkbox"/>			
Value	Input terminal (1)																																													
0	OFF fixed																																													
1	PSI1																																													
2	PSI2																																													
3	PSI3																																													
4	PSI4																																													
5	PSI5																																													
6	PSI6 Optional																																													
7	PSI7 Optional																																													
8	PSI8 Optional																																													
9	PSI9 Optional																																													
10	(PL0) Program outputs																																													
11	(PL1) (For future use)																																													
12	(PL2)																																													
13	(PL3)																																													
14	EMS																																													
15	FRUN																																													
16	ON Fixed																																													
1	F-JOG (Forward Jog)		2.			<input type="checkbox"/>																																								
2	R-JOG (Reverse Jog)		3.			<input type="checkbox"/>																																								
3	HOLD (Hold signal)		0.			<input type="checkbox"/>																																								
4	BRAKE (DC Brake)		0.			<input type="checkbox"/>																																								
5	COP (Serial transsm.)		0.			<input type="checkbox"/>																																								
6	CSEL (Dual ramp.)		0.			<input type="checkbox"/>																																								
7	IPASS (Interlock bypass)		0.			<input type="checkbox"/>																																								
8	PIDEN (PID)		0.			<input type="checkbox"/>																																								
<b>C04 – Sequence input function – 2</b>																																														
0	CPASS (Ramp bypass)		0.	0.	16.	<input type="checkbox"/>																																								
1	VFS (Speed setting1)		16.			<input type="checkbox"/>																																								
2	IFS (Speed setting2)		0.			<input type="checkbox"/>																																								
3	AUX (Speed setting3)		0.			<input type="checkbox"/>																																								
4	PROG (Multi-speed)		0.			<input type="checkbox"/>																																								
5	CFS (CPU setting)		0.			<input type="checkbox"/>																																								
6	S0 (Aux. selector)		0.			<input type="checkbox"/>																																								
7	S1 (Aux. selector)		0.			<input type="checkbox"/>																																								
8	S2 (Aux. selector)		0.			<input type="checkbox"/>																																								
9	S3 (Aux. selector)		0.			<input type="checkbox"/>																																								
<b>C05 – Sequence input terminal function – 3</b>																																														
0	SE (Aux. selector)		0.	0.	16.	<p><b>(1) Notes:</b></p> <ul style="list-style-type: none"> <li>When one function is set to ON (=16), it is permanently enabled.</li> <li>When one function is set to OFF (=0), it is permanently disabled.</li> <li>When one function is set to any programmable input PSI1 to PSI9 (=1-9), the function is remotely enabled or disabled according the status ON/OFF of the input assigned</li> </ul>	<input type="checkbox"/>																																							
1	FUP (Frequency Up)		0.				<input type="checkbox"/>																																							
2	FDW (Frequency Down)		0.				<input type="checkbox"/>																																							
3	BUP (ratio interlock Up)		0.				<input type="checkbox"/>																																							
4	BDW (ratio interlock Down)		0.				<input type="checkbox"/>																																							
5	IVLM (ratio interlock Up/Down bypass)		0.				<input type="checkbox"/>																																							
6	AUXDV (Dual drive)		0.				<input type="checkbox"/>																																							
7	PICK (Pick Up)		0.				<input type="checkbox"/>																																							
8	EXC (Pre-excitation)		0.						<input type="checkbox"/>																																					
9	ACR (Torque control)		0.						<input type="checkbox"/>	<input type="checkbox"/>																																				
<b>C06 – Sequence input terminal function – 4</b>																																														
0	PCTL (Proportional Control ASR)		0.	0.	16.			<input type="checkbox"/>	<input type="checkbox"/>																																					
1	LIM1 (Drive torque Limit)		0.					<input type="checkbox"/>	<input type="checkbox"/>																																					
2	LIM2 (Regenerative torque Limit)		0.					<input type="checkbox"/>	<input type="checkbox"/>																																					
3	MCH (Load time constant)		0.					<input type="checkbox"/>	<input type="checkbox"/>																																					
4	RF0 (0 setting)		0.					<input type="checkbox"/>	<input type="checkbox"/>																																					
5	DROOP(Drooping)		0.					<input type="checkbox"/>	<input type="checkbox"/>																																					
6	DEDB (Dead band)		0.					<input type="checkbox"/>	<input type="checkbox"/>																																					
7	TRQB1 (Torque bias 1)		0.					<input type="checkbox"/>	<input type="checkbox"/>																																					
8	TRQB2 (Torque bias 2)		0.					<input type="checkbox"/>	<input type="checkbox"/>																																					

6. Control Functions and Parameter Settings

Block-C parameters (Basic function constants) list

No.	Parameter	Unit	Default	Min.	Max.	Function	Application																																																						
							ST	V/f	VEC	PM																																																			
<b>C07 – Analog input terminal function</b>																																																													
0	Speed setting 1		2.	0.	7.	<table border="1"> <thead> <tr> <th>Value</th> <th>Input terminal (1)</th> </tr> </thead> <tbody> <tr> <td>0</td> <td>0% fixed</td> </tr> <tr> <td>1</td> <td>100% fixed</td> </tr> <tr> <td>2</td> <td>FSV</td> </tr> <tr> <td>3</td> <td>FSI</td> </tr> <tr> <td>4</td> <td>AUX</td> </tr> <tr> <td>5</td> <td>PAI4 (optional)</td> </tr> <tr> <td>6</td> <td>PAI5 (optional)</td> </tr> <tr> <td>7</td> <td>PAI6 (optional)</td> </tr> </tbody> </table>	Value	Input terminal (1)	0	0% fixed	1	100% fixed	2	FSV	3	FSI	4	AUX	5	PAI4 (optional)	6	PAI5 (optional)	7	PAI6 (optional)	<input type="radio"/>																																				
Value	Input terminal (1)																																																												
0	0% fixed																																																												
1	100% fixed																																																												
2	FSV																																																												
3	FSI																																																												
4	AUX																																																												
5	PAI4 (optional)																																																												
6	PAI5 (optional)																																																												
7	PAI6 (optional)																																																												
1	Speed setting 2		3.	0.	7.	<input type="radio"/>																																																							
2	Speed setting 3		0.	0.	7.	<input type="radio"/>																																																							
3	Ratio interlock bias setting		0.	0.	7.	<input type="radio"/>																																																							
4	Traverse center frequency		0.	0.	7.	<input type="radio"/>																																																							
5	PID feedback		0.	0.	7.	<input type="radio"/>																																																							
6	Torque setting		0.	0.	7.			<input type="radio"/>	<input type="radio"/>																																																				
7	Drive torque limit reduction setting		1.	0.	7.			<input type="radio"/>	<input type="radio"/>																																																				
8	Regenerative torque limit reduction setting		1.	0.	7.			<input type="radio"/>	<input type="radio"/>																																																				
9	Torque bias 1 setting		0.	0.	7.			<input type="radio"/>	<input type="radio"/>																																																				
<b>C08 – Automatic start setting</b>																																																													
0	Auto start (To F-RUN/R-RUN)		1.	1.	3.	= 1 : off = 2 : on without pick-up = 3 : on with pick-up (re-start after a momentary power loss)	<input type="radio"/>																																																						
<b>C09 – Parameter protection/operation locks</b>																																																													
0	Parameter protection		1.	1.	9.	Set to prevent unintentional operation from the operation panel (OPU). Set whether to enable or lock data changing for each parameter function unit as shown above.	<input type="radio"/>																																																						
		<b>Parameter protection:</b> <input type="radio"/> : Unprotected (changeable) <input type="checkbox"/> : Protected (unchangeable)		<table border="1"> <thead> <tr> <th rowspan="2">Setting value</th> <th rowspan="2">Block A</th> <th colspan="4">Block B, C</th> </tr> <tr> <th>Basic</th> <th>Extended</th> <th>S/W</th> <th>H/W</th> </tr> </thead> <tbody> <tr> <td>1</td> <td><input type="radio"/></td> <td><input type="radio"/></td> <td><input type="radio"/></td> <td><input type="radio"/></td> <td><input type="radio"/></td> </tr> <tr> <td>2</td> <td><input checked="" type="checkbox"/></td> <td><input checked="" type="checkbox"/></td> <td><input checked="" type="checkbox"/></td> <td><input checked="" type="checkbox"/></td> <td><input checked="" type="checkbox"/></td> </tr> <tr> <td>3</td> <td><input type="radio"/></td> <td><input checked="" type="checkbox"/></td> <td><input checked="" type="checkbox"/></td> <td><input checked="" type="checkbox"/></td> <td><input checked="" type="checkbox"/></td> </tr> <tr> <td>4</td> <td><input type="radio"/></td> <td><input checked="" type="checkbox"/></td> <td><input type="radio"/></td> <td><input checked="" type="checkbox"/></td> <td><input checked="" type="checkbox"/></td> </tr> <tr> <td>5</td> <td><input type="radio"/></td> <td><input checked="" type="checkbox"/></td> <td><input type="radio"/></td> <td><input type="radio"/></td> <td><input checked="" type="checkbox"/></td> </tr> <tr> <td>6~8</td> <td><input checked="" type="checkbox"/></td> <td><input checked="" type="checkbox"/></td> <td><input checked="" type="checkbox"/></td> <td><input checked="" type="checkbox"/></td> <td><input checked="" type="checkbox"/></td> </tr> <tr> <td>9</td> <td><input type="radio"/></td> <td><input type="radio"/></td> <td><input type="radio"/></td> <td><input type="radio"/></td> <td><input type="radio"/></td> </tr> </tbody> </table>		Setting value	Block A	Block B, C				Basic	Extended	S/W	H/W	1	<input type="radio"/>	<input type="radio"/>	<input type="radio"/>	<input type="radio"/>	<input type="radio"/>	2	<input checked="" type="checkbox"/>	<input checked="" type="checkbox"/>	<input checked="" type="checkbox"/>	<input checked="" type="checkbox"/>	<input checked="" type="checkbox"/>	3	<input type="radio"/>	<input checked="" type="checkbox"/>	<input checked="" type="checkbox"/>	<input checked="" type="checkbox"/>	<input checked="" type="checkbox"/>	4	<input type="radio"/>	<input checked="" type="checkbox"/>	<input type="radio"/>	<input checked="" type="checkbox"/>	<input checked="" type="checkbox"/>	5	<input type="radio"/>	<input checked="" type="checkbox"/>	<input type="radio"/>	<input type="radio"/>	<input checked="" type="checkbox"/>	6~8	<input checked="" type="checkbox"/>	<input checked="" type="checkbox"/>	<input checked="" type="checkbox"/>	<input checked="" type="checkbox"/>	<input checked="" type="checkbox"/>	9	<input type="radio"/>	<input type="radio"/>	<input type="radio"/>	<input type="radio"/>	<input type="radio"/>				
Setting value	Block A	Block B, C																																																											
		Basic	Extended	S/W	H/W																																																								
1	<input type="radio"/>	<input type="radio"/>	<input type="radio"/>	<input type="radio"/>	<input type="radio"/>																																																								
2	<input checked="" type="checkbox"/>	<input checked="" type="checkbox"/>	<input checked="" type="checkbox"/>	<input checked="" type="checkbox"/>	<input checked="" type="checkbox"/>																																																								
3	<input type="radio"/>	<input checked="" type="checkbox"/>	<input checked="" type="checkbox"/>	<input checked="" type="checkbox"/>	<input checked="" type="checkbox"/>																																																								
4	<input type="radio"/>	<input checked="" type="checkbox"/>	<input type="radio"/>	<input checked="" type="checkbox"/>	<input checked="" type="checkbox"/>																																																								
5	<input type="radio"/>	<input checked="" type="checkbox"/>	<input type="radio"/>	<input type="radio"/>	<input checked="" type="checkbox"/>																																																								
6~8	<input checked="" type="checkbox"/>	<input checked="" type="checkbox"/>	<input checked="" type="checkbox"/>	<input checked="" type="checkbox"/>	<input checked="" type="checkbox"/>																																																								
9	<input type="radio"/>	<input type="radio"/>	<input type="radio"/>	<input type="radio"/>	<input type="radio"/>																																																								
1	Operation panel lock		1.	1.	3.	= 1 : Enables control from keypad = 2 : Disables control from keypad (The STOP key will stop the drive, if pressed for 2 seconds. = 3 : Only STOP key is available	<input type="radio"/>																																																						
2	LCL switchover protection		1.	1.	2.	= 1 : Disables switchover while the drive is running = 2 : Enables switchover while the drive is running	<input type="radio"/>																																																						
3	Reverse run (sequence R RUN) lock		1.	1.	2.	Set this to prevent unintentional reverse run operation. When set to "2", the sequence input "R RUN" operation command will be disabled. Note that if the reverse run setting (negative value) is input into the speed setting during "F-RUN" operation, reverse run will start. = 1 : Enable = 2 : lock	<input type="radio"/>																																																						

## 6. Control Functions and Parameter Settings

### Block-C parameters (Basic function constants) list

No.	Parameter	Unit	Default	Min.	Max.	Function	Application			
							ST	V/f	VEC	PM
<b>C09 – Parameter protection/operation locks</b>										
4	Reverse run jogging (sequence R JOG) lock		1.	1.	2.	Set this to prevent unintentional reverse jogging operation. When set to "2", the "R-JOG" operation command will be disabled. Note that if the reverse run setting (negative value) is input into the jogging setting during "F-JOG" operation, reverse run will start. = 1 : Enable = 2 : Lock	○			
5	Reverse run during ACR mode lock		1.	1.	2.	Set this to prevent unintentional reverse run operation. When set to "2", reverse run during ACR operation will be cancel. The reverse run speed will be limited to approx. 1% if reverse run is started. This setting is ignored in the V/f mode. = 1 : Enable = 2 : Lock			○	
6	Fault history buffer clear		0.	0	9999	Set 1 for the setting value to clear the fault history details. The clearing operation will not take place at a setting other than 1. 1: Clear fault history	○			
7	Default value load		0.	0	9999	9: All default values load (excluding maintenance) 10: Parameter A 11: Parameters B, C basic functions 12: Parameters B, C extended functions 13: Parameter B software option function Parameter C hardware option function 14: Parameters B basic functions 15: Parameters B extended functions 16: Parameter B software option function 17: Parameters C basic functions 18: Parameters C extended functions 19: Parameter C hardware option function	○			
<b>C10 – Custom parameter register</b>										
0	Custom-0		1.99.9	1.00.0	2.99.9	Set for each parameter No. to be displayed and changed as an A04-0 to 7 custom parameter. <b>Example)</b> To set B13-0 (torque setting), set as 1.13.0.	○			
1	-1									
2	-2									
3	-3									
4	-4									
5	-5									
6	-6									
7	-7									

## 6. Control Functions and Parameter Settings

### Block-C parameters (Basic function constants) list

No.	Parameter	Unit	Default	Min.	Max.	Function	Application																																																																	
							ST	V/f	VEC	PM																																																														
<b>C11 – Operation panel mode setting</b>																																																																								
0	Initial mode		1.	1.	2.	The initial operation mode for when the power is turned ON is set = 1 : Local = 2 : Remote	○																																																																	
1	Run command status		1.	1.	3.	This is the initial operation mode at power ON, during local operation mode (operation from operation panel) if the automatic start function (C08-0 =2 or 3) is enabled.  = 1 : Stop = 2 : Forward run = 3 : Reverse run	○																																																																	
3	Operation panel monitor settings		0.0	0.0	99.9	Set the monitor parameter No. to be displayed initially when the power is turned ON.	○																																																																	
<b>C12 – Setting input terminal function</b>																																																																								
0	FSV terminal input mode		1.	1.	3.	1: 0 ~ 10V, 2: 0 ~ 5V, 3: 1 ~ 5V	○																																																																	
1	FSI terminal input mode		1.	1.	2.	1: 4 ~ 20mA, 2: 0 ~ 20mA	○																																																																	
2	AUX terminal input mode		1.	1.	3.	1: 0 ~ ±10V, 2: 0 ~ ±5V, 3: 1 ~ 5V	○																																																																	
3	Filter time constant for FSV/FSI and AUX input		1.	1.	2.	1: 8ms 2: 32ms	○																																																																	
4	AUX input gain		1.000	0.000	5.000		○																																																																	
<b>C13 – Output terminal function</b>																																																																								
0	FM output settings		0.	0.	12.	Select the setting value from the following table, and output.	○																																																																	
1	AM output settings		3.	0.	12.		○																																																																	
The terminal voltage can be changed freely with parameters C14-0.1																																																																								
<table border="1" style="width: 100%; border-collapse: collapse;"> <thead> <tr> <th>Value</th> <th>Parameter</th> <th>Output Voltage</th> </tr> </thead> <tbody> <tr> <td>0</td> <td>Output frequency</td> <td>10V at max. frequency</td> </tr> <tr> <td>1</td> <td>Setting frequency Setting Speed</td> <td>10V at max. frequency 10V at max. speed</td> </tr> <tr> <td>2</td> <td>Ramp output</td> <td>10V at max. frequency 10V at max. speed</td> </tr> <tr> <td>3</td> <td>Output current (motor)</td> <td>5V at motor rated current</td> </tr> <tr> <td>4</td> <td>Output current (drive)</td> <td>5V at drive rated current</td> </tr> <tr> <td>5</td> <td>Output Voltage</td> <td>10V at rated Voltage</td> </tr> <tr> <td>6</td> <td>Output power (drive)</td> <td>5V at motor rated power</td> </tr> </tbody> </table>			Value	Parameter	Output Voltage	0	Output frequency	10V at max. frequency	1	Setting frequency Setting Speed	10V at max. frequency 10V at max. speed	2	Ramp output	10V at max. frequency 10V at max. speed	3	Output current (motor)	5V at motor rated current	4	Output current (drive)	5V at drive rated current	5	Output Voltage	10V at rated Voltage	6	Output power (drive)	5V at motor rated power	<table border="1" style="width: 100%; border-collapse: collapse;"> <thead> <tr> <th>Value</th> <th>Parameter</th> <th>Output Voltage</th> </tr> </thead> <tbody> <tr> <td>7</td> <td>DC Voltage</td> <td>5V at 300V (200V Series) 5V at 600V (400V Series)</td> </tr> <tr> <td>8</td> <td>OLT Monitor</td> <td>10V at 100%</td> </tr> <tr> <td>9</td> <td>Heatsink Temperature</td> <td>10V at 100°C</td> </tr> <tr> <td>10</td> <td>Motor speed</td> <td>10V at max. speed</td> </tr> <tr> <td>11</td> <td>Torque current</td> <td>5V at motor rated current</td> </tr> <tr> <td>12</td> <td>Excitation current</td> <td>5V at motor rated current</td> </tr> </tbody> </table>			Value	Parameter	Output Voltage	7	DC Voltage	5V at 300V (200V Series) 5V at 600V (400V Series)	8	OLT Monitor	10V at 100%	9	Heatsink Temperature	10V at 100°C	10	Motor speed	10V at max. speed	11	Torque current	5V at motor rated current	12	Excitation current	5V at motor rated current																						
Value	Parameter	Output Voltage																																																																						
0	Output frequency	10V at max. frequency																																																																						
1	Setting frequency Setting Speed	10V at max. frequency 10V at max. speed																																																																						
2	Ramp output	10V at max. frequency 10V at max. speed																																																																						
3	Output current (motor)	5V at motor rated current																																																																						
4	Output current (drive)	5V at drive rated current																																																																						
5	Output Voltage	10V at rated Voltage																																																																						
6	Output power (drive)	5V at motor rated power																																																																						
Value	Parameter	Output Voltage																																																																						
7	DC Voltage	5V at 300V (200V Series) 5V at 600V (400V Series)																																																																						
8	OLT Monitor	10V at 100%																																																																						
9	Heatsink Temperature	10V at 100°C																																																																						
10	Motor speed	10V at max. speed																																																																						
11	Torque current	5V at motor rated current																																																																						
12	Excitation current	5V at motor rated current																																																																						
2	RC-RA output settings		0.	0.	24.	Select the setting value from the following table, and output.	○																																																																	
3	PSO1 output settings		3.	0.	24.		○																																																																	
4	PSO2 output settings		7.	0.	24.		○																																																																	
5	PSO3 output settings		8.	0.	24.		○																																																																	
<table style="width: 100%; border-collapse: collapse;"> <tr> <td style="width: 25%; border: 1px solid black;"> <table border="1" style="width: 100%; border-collapse: collapse;"> <thead> <tr> <th>Value</th> <th>Output signal</th> </tr> </thead> <tbody> <tr><td>0</td><td>RUN</td></tr> <tr><td>1</td><td>FLT</td></tr> <tr><td>2</td><td>MC</td></tr> <tr><td>3</td><td>RDY1</td></tr> <tr><td>4</td><td>RDY2</td></tr> <tr><td>5</td><td>LCL</td></tr> <tr><td>6</td><td>REV</td></tr> <tr><td>7</td><td>IDET</td></tr> </tbody> </table> </td> <td style="width: 25%; border: 1px solid black;"> <table border="1" style="width: 100%; border-collapse: collapse;"> <thead> <tr> <th>Value</th> <th>Output signal</th> </tr> </thead> <tbody> <tr><td>8</td><td>ATN</td></tr> <tr><td>9</td><td>SPD1</td></tr> <tr><td>10</td><td>SPD2</td></tr> <tr><td>11</td><td>COP</td></tr> <tr><td>12</td><td>EC0</td></tr> <tr><td>13</td><td>EC1</td></tr> <tr><td>14</td><td>EC2</td></tr> <tr><td>15</td><td>EC3</td></tr> </tbody> </table> </td> <td style="width: 25%; border: 1px solid black;"> <table border="1" style="width: 100%; border-collapse: collapse;"> <thead> <tr> <th>Value</th> <th>Output signal</th> </tr> </thead> <tbody> <tr><td>16</td><td>ACC</td></tr> <tr><td>17</td><td>DCC</td></tr> <tr><td>18</td><td>AUXDV</td></tr> <tr><td>19</td><td>ALM</td></tr> <tr><td>20</td><td>FAN</td></tr> <tr><td>21</td><td>ASW</td></tr> <tr><td>22</td><td>ZSP</td></tr> <tr><td>23</td><td>LLMT</td></tr> </tbody> </table> </td> <td style="width: 25%; border: 1px solid black;"> <table border="1" style="width: 100%; border-collapse: collapse;"> <thead> <tr> <th>Value</th> <th>Output signal</th> </tr> </thead> <tbody> <tr> <td>24</td> <td>ULMT</td> </tr> </tbody> </table> </td> </tr> </table>											<table border="1" style="width: 100%; border-collapse: collapse;"> <thead> <tr> <th>Value</th> <th>Output signal</th> </tr> </thead> <tbody> <tr><td>0</td><td>RUN</td></tr> <tr><td>1</td><td>FLT</td></tr> <tr><td>2</td><td>MC</td></tr> <tr><td>3</td><td>RDY1</td></tr> <tr><td>4</td><td>RDY2</td></tr> <tr><td>5</td><td>LCL</td></tr> <tr><td>6</td><td>REV</td></tr> <tr><td>7</td><td>IDET</td></tr> </tbody> </table>	Value	Output signal	0	RUN	1	FLT	2	MC	3	RDY1	4	RDY2	5	LCL	6	REV	7	IDET	<table border="1" style="width: 100%; border-collapse: collapse;"> <thead> <tr> <th>Value</th> <th>Output signal</th> </tr> </thead> <tbody> <tr><td>8</td><td>ATN</td></tr> <tr><td>9</td><td>SPD1</td></tr> <tr><td>10</td><td>SPD2</td></tr> <tr><td>11</td><td>COP</td></tr> <tr><td>12</td><td>EC0</td></tr> <tr><td>13</td><td>EC1</td></tr> <tr><td>14</td><td>EC2</td></tr> <tr><td>15</td><td>EC3</td></tr> </tbody> </table>	Value	Output signal	8	ATN	9	SPD1	10	SPD2	11	COP	12	EC0	13	EC1	14	EC2	15	EC3	<table border="1" style="width: 100%; border-collapse: collapse;"> <thead> <tr> <th>Value</th> <th>Output signal</th> </tr> </thead> <tbody> <tr><td>16</td><td>ACC</td></tr> <tr><td>17</td><td>DCC</td></tr> <tr><td>18</td><td>AUXDV</td></tr> <tr><td>19</td><td>ALM</td></tr> <tr><td>20</td><td>FAN</td></tr> <tr><td>21</td><td>ASW</td></tr> <tr><td>22</td><td>ZSP</td></tr> <tr><td>23</td><td>LLMT</td></tr> </tbody> </table>	Value	Output signal	16	ACC	17	DCC	18	AUXDV	19	ALM	20	FAN	21	ASW	22	ZSP	23	LLMT	<table border="1" style="width: 100%; border-collapse: collapse;"> <thead> <tr> <th>Value</th> <th>Output signal</th> </tr> </thead> <tbody> <tr> <td>24</td> <td>ULMT</td> </tr> </tbody> </table>	Value	Output signal	24	ULMT
<table border="1" style="width: 100%; border-collapse: collapse;"> <thead> <tr> <th>Value</th> <th>Output signal</th> </tr> </thead> <tbody> <tr><td>0</td><td>RUN</td></tr> <tr><td>1</td><td>FLT</td></tr> <tr><td>2</td><td>MC</td></tr> <tr><td>3</td><td>RDY1</td></tr> <tr><td>4</td><td>RDY2</td></tr> <tr><td>5</td><td>LCL</td></tr> <tr><td>6</td><td>REV</td></tr> <tr><td>7</td><td>IDET</td></tr> </tbody> </table>	Value	Output signal	0	RUN	1	FLT	2	MC	3	RDY1	4	RDY2	5	LCL	6	REV	7	IDET	<table border="1" style="width: 100%; border-collapse: collapse;"> <thead> <tr> <th>Value</th> <th>Output signal</th> </tr> </thead> <tbody> <tr><td>8</td><td>ATN</td></tr> <tr><td>9</td><td>SPD1</td></tr> <tr><td>10</td><td>SPD2</td></tr> <tr><td>11</td><td>COP</td></tr> <tr><td>12</td><td>EC0</td></tr> <tr><td>13</td><td>EC1</td></tr> <tr><td>14</td><td>EC2</td></tr> <tr><td>15</td><td>EC3</td></tr> </tbody> </table>	Value	Output signal	8	ATN	9	SPD1	10	SPD2	11	COP	12	EC0	13	EC1	14	EC2	15	EC3	<table border="1" style="width: 100%; border-collapse: collapse;"> <thead> <tr> <th>Value</th> <th>Output signal</th> </tr> </thead> <tbody> <tr><td>16</td><td>ACC</td></tr> <tr><td>17</td><td>DCC</td></tr> <tr><td>18</td><td>AUXDV</td></tr> <tr><td>19</td><td>ALM</td></tr> <tr><td>20</td><td>FAN</td></tr> <tr><td>21</td><td>ASW</td></tr> <tr><td>22</td><td>ZSP</td></tr> <tr><td>23</td><td>LLMT</td></tr> </tbody> </table>	Value	Output signal	16	ACC	17	DCC	18	AUXDV	19	ALM	20	FAN	21	ASW	22	ZSP	23	LLMT	<table border="1" style="width: 100%; border-collapse: collapse;"> <thead> <tr> <th>Value</th> <th>Output signal</th> </tr> </thead> <tbody> <tr> <td>24</td> <td>ULMT</td> </tr> </tbody> </table>	Value	Output signal	24	ULMT											
Value	Output signal																																																																							
0	RUN																																																																							
1	FLT																																																																							
2	MC																																																																							
3	RDY1																																																																							
4	RDY2																																																																							
5	LCL																																																																							
6	REV																																																																							
7	IDET																																																																							
Value	Output signal																																																																							
8	ATN																																																																							
9	SPD1																																																																							
10	SPD2																																																																							
11	COP																																																																							
12	EC0																																																																							
13	EC1																																																																							
14	EC2																																																																							
15	EC3																																																																							
Value	Output signal																																																																							
16	ACC																																																																							
17	DCC																																																																							
18	AUXDV																																																																							
19	ALM																																																																							
20	FAN																																																																							
21	ASW																																																																							
22	ZSP																																																																							
23	LLMT																																																																							
Value	Output signal																																																																							
24	ULMT																																																																							

## 6. Control Functions and Parameter Settings

### Block-C parameters (Basic function constants) list

No.	Parameter	Unit	Default	Min.	Max.	Function	Application			
							ST	V/f	VEC	PM
<b>C14 – Meter output gain</b>										
0	Output gain for FM		1.00	0.20	2.00	10V at Max. frequency when this is set to 1.00. 5V at the rated current when this is set to 1.00. (Max. 11V)	○			
1	Output gain for AM		1.00	0.20	2.00		○			
<b>C15 – Status output detection level</b>										
0	Attainment (ATN) detection width	%	1.0	0.0	20.0	The attained output (ATN) operation width is set.	○			
1	Current (IDET) detection level	%	100.	5.	300.	The current detection (IDET) operation level is set.	○			
2	Speed detection (SPD1) level – 1	%	95.0	1.0	105.0	The speed detection (SPD1, SPD2) operation level is set.	○			
3	Speed detection (SPD2) level – 2	%	50.0	1.0	105.0		○			
4	Zero speed detection (ZSP) level	%	1.00	0.00	50.00	The zero speed detection (ZSP) operation level is set.	○			

## 6. Control Functions and Parameter Settings

### Block-C parameters (Extended function constants) list

No.	Parameter	Unit	Default	Min.	Max.	Function	Application			
							ST	V/f	VEC	PM
<b>C20 – Start interlock</b>										
0	Start/stop frequency (speed)	%	0.0	0.0	20.0	The motor will stop when below this frequency setting.	○			
1	Start/stop frequency (speed) hysteresis	%	1.0	0.0	20.0		○			
2	Interlock frequency (speed)	%	0.0	0.0	20.0	The motor will not start when the speed or frequency setting is lower than this frequency.  When C20-0=0, the setting start/stop will not operate. When C20-2=0, the setting interlock will not operate.	○			
3	RUN delay timer	sec	0.00	0.00	10.00	Delays F RUN or R RUN operation	○			
<b>C21 – Retry/pick-up</b>										
0	Number of retries		0.	0.	10.	No of re-start tries after a fault	○			
1	Retry wait time	sec	5.	1.	30.	Delay time between tries	○			
2	Pick-up wait time	sec	2.	1.	10.	Delay time before pick-up	○			
3	Pick-up current limit value	%	100.	50.	300.	Do not set a value less than the excitation current.	○			
<b>C22 – Overload</b>										
0	Overload setting	%	100.	50.	105.	Note that when this parameter is changed, Parameters C22-1 and C22-2 will automatically be adjusted to the value of this setting.	○			
1	0Hz overload	%	100.	20.	105.	The maximum value is as set on C22-2.	○			
2	0.7Base freq.overload	%	100.	50.	105.	The minimum value is as set on C22-1.	○			
3	DBR overload	%	1.6	0.0	10.0	This is %ED of DBR operation for drives with built in dynamic braking. Set 0.0 to disable protection or when an external DBR module is used	○			
4	Motor loss braking setting	%	50.0	0.0	70.0	This function is valid when control mode selection is C30=1,2 and DBR option selection is C31-0=3,4	○			
C22-0~2: The max. value differs according to the load characteristic selection (C30-0). When C30-0=2 (when variable torque is selected), these max. value is 100.										
<b>C23 – Start/Stop frequency-Overload (Dual drive)</b>										
0	Start frequency	Hz	1.0	0.1	60.0		○			
1	Stop frequency (DC Brake start)	Hz	1.0	0.1	60.0		○			
2	Overload setting	%	100.	50.	105.	Note that when this parameter is changed, Parameters C23-3 and C23-4 will automatically be adjusted to the value of this setting.	○			
3	0Hz overload	%	100.	20.	105.	The maximum value is as set on C23-4.	○			
4	0.7Base freq.overload	%	100.	50.	105.	The minimum value is as set on C23-3.	○			

## 6. Control Functions and Parameter Settings

### Block-C parameters (Extended function constants) list

No.	Parameter	Unit	Default	Min.	Max.	Function	Application																																											
							ST	V/f	VEC	PM																																								
<b>C24 – Speed detection error monitor</b>																																																		
0	Overspeed protection level	%	105.0	100.0	200.0	The overspeed protection operation level is set.			○	○																																								
1	Control mode change-over during speed detection error		1.	1.	3.	Select control at speed detection error = 1 : Speed detection error not monitored = 2 : Speed detection error monitored (Do not change to sensor-less vector control) = 3 : Speed detection error monitored (Switch to sensor-less vector control) When PM motor control is enabled (C30-0=5), set C24-1 to 1 or 2 only.			○	○																																								
2	Speed detection error level	%	10.0	1.0	100.0	The conditions for judging the speed detection error are set. Set as C24-2 ≥ C24-3.			○	○																																								
3	Speed detection error recovery level	%	5.0	1.0	100.0				○																																									
<b>C25 – High-efficiency operation</b>																																																		
0	Voltage reduction time	sec	10.0	0.1	30.0	Set the time for the output voltage to drop from the V/f setting value to 0V.	○																																											
1	Voltage lower limit setting value	%	100.	10.	100.	When selecting a high-efficiency operation function, set 10 to 99.	○																																											
2	Cooling fan ON/OFF control		2.	1.	2.	= 1 : ON/OFF control is enabled. Fan is ON while inverter runs. = 2 : ON/OFF control is disabled. Fan is always ON.	○																																											
<b>C26 – Standard serial transmission setting</b>																																																		
0	Parameter change lock		1.	1.	5.	The parameters are shown in below table	○																																											
						<table border="1" style="margin-left: auto; margin-right: auto;"> <thead> <tr> <th rowspan="2">Setting value</th> <th rowspan="2">Block A</th> <th colspan="4">Block B, C</th> </tr> <tr> <th>Basic</th> <th>Extend</th> <th>S/W</th> <th>H/W</th> </tr> </thead> <tbody> <tr> <td>1</td> <td>○</td> <td>○</td> <td>○</td> <td>○</td> <td>○</td> </tr> <tr> <td>2</td> <td>X</td> <td>X</td> <td>X</td> <td>X</td> <td>X</td> </tr> <tr> <td>3</td> <td>○</td> <td>X</td> <td>X</td> <td>X</td> <td>X</td> </tr> <tr> <td>4</td> <td>○</td> <td>X</td> <td>○</td> <td>X</td> <td>X</td> </tr> <tr> <td>5</td> <td>○</td> <td>X</td> <td>○</td> <td>○</td> <td>X</td> </tr> </tbody> </table> <p style="text-align: center;">○: Changeable    X: Lock</p>					Setting value	Block A	Block B, C				Basic	Extend	S/W	H/W	1	○	○	○	○	○	2	X	X	X	X	X	3	○	X	X	X	X	4	○	X	○	X	X	5	○	X	○	○	X
Setting value	Block A	Block B, C																																																
		Basic	Extend	S/W	H/W																																													
1	○	○	○	○	○																																													
2	X	X	X	X	X																																													
3	○	X	X	X	X																																													
4	○	X	○	X	X																																													
5	○	X	○	○	X																																													
1	Station Number		1.	0.	32.	Set the station number	○																																											
2	Response timer	sec	0.00	0.00	2.00	Set the minimum time for returning an answer after receiving the command	○																																											
Refer to instruction manual (PCST-3298)																																																		

## 6. Control Functions and Parameter Settings

### Block-C parameters (H/W extended functions) list

No.	Parameter	Unit	Default	Min.	Max.	Function	Application																																																			
							ST	V/f	VEC	PM																																																
<b>C30 – Control mode selection</b>																																																										
0	Control mode selection		—	1.	5.	The control mode is set. = 1 : V/f control (constant torque: overload characteristics 150% for one minute.) = 2 : V/f control (variable torque: overload characteristics 120% for one minute.) = 3 : Speed sensor-less vector control = 4 : Speed vector control with sensor = 5 : PM Motor control	○																																																			
<b>C31 – Main circuit option selection</b>																																																										
0	DBR option selection		1.	1.	4.	= 1 : Both Dynamic braking and motor loss braking disabled = 2 : Dynamic Braking enabled = 3 : Motor loss braking enabled = 4 : Both Dynamic braking and motor loss braking enabled	○																																																			
1	Ground fault detection function		1.	1.	2.	= 1 : Enabled = 2 : Disabled	○																																																			
<b>C32 – PC Parallel interface</b>																																																										
0	Input mode (strobe)		1.	1.	3.	= 1 : 16-bit = 2 : 8-bit = 3 : 16-bit sample	○																																																			
1	Input mode (input logic)		1.	1.	2.	= 1 : 1 at ON input status = 2 : 0 at OFF input status	○																																																			
2	Data format		1.	0.	10.	Set according to the following table	○																																																			
<table border="1" style="width: 100%; border-collapse: collapse;"> <thead> <tr> <th>Setting data</th> <th>Format</th> <th>Setting resolution</th> <th>Setting range</th> </tr> </thead> <tbody> <tr> <td>0</td> <td>16-bits binary</td> <td>0,01Hz/LSB (0.1rpm/LSB)</td> <td>0 to 440.00Hz</td> </tr> <tr> <td>1</td> <td>16-bits binary</td> <td>0,01Hz/LSB (1rpm/LSB)</td> <td>440.0 Hz</td> </tr> <tr> <td>2</td> <td>16-bits binary</td> <td>0,01%/LSB</td> <td>100.00%</td> </tr> <tr> <td>3</td> <td>16-bits binary</td> <td>0,1%/LSB</td> <td>100.0%</td> </tr> <tr> <td>4</td> <td>16-bits BCD</td> <td>0,01Hz/LSB (0.1rpm/LSB)</td> <td>99.99Hz</td> </tr> <tr> <td>5</td> <td>16-bits BCD</td> <td>0,01Hz/LSB (1rpm/LSB)</td> <td>100.0Hz</td> </tr> <tr> <td>6</td> <td>16-bits BCD</td> <td>0,01%/LSB</td> <td>99.99%</td> </tr> <tr> <td>7</td> <td>16-bits BCD</td> <td>0,1%/LSB</td> <td>100.0%</td> </tr> <tr> <td>8</td> <td>8-bits BCD</td> <td>1/255%</td> <td>100.0%</td> </tr> <tr> <td>9</td> <td>12-bits BCD</td> <td>1/4095%</td> <td>100.0%</td> </tr> <tr> <td>10</td> <td>16-bits BCD</td> <td>1/65535%</td> <td>100.0%</td> </tr> </tbody> </table>											Setting data	Format	Setting resolution	Setting range	0	16-bits binary	0,01Hz/LSB (0.1rpm/LSB)	0 to 440.00Hz	1	16-bits binary	0,01Hz/LSB (1rpm/LSB)	440.0 Hz	2	16-bits binary	0,01%/LSB	100.00%	3	16-bits binary	0,1%/LSB	100.0%	4	16-bits BCD	0,01Hz/LSB (0.1rpm/LSB)	99.99Hz	5	16-bits BCD	0,01Hz/LSB (1rpm/LSB)	100.0Hz	6	16-bits BCD	0,01%/LSB	99.99%	7	16-bits BCD	0,1%/LSB	100.0%	8	8-bits BCD	1/255%	100.0%	9	12-bits BCD	1/4095%	100.0%	10	16-bits BCD	1/65535%	100.0%
Setting data	Format	Setting resolution	Setting range																																																							
0	16-bits binary	0,01Hz/LSB (0.1rpm/LSB)	0 to 440.00Hz																																																							
1	16-bits binary	0,01Hz/LSB (1rpm/LSB)	440.0 Hz																																																							
2	16-bits binary	0,01%/LSB	100.00%																																																							
3	16-bits binary	0,1%/LSB	100.0%																																																							
4	16-bits BCD	0,01Hz/LSB (0.1rpm/LSB)	99.99Hz																																																							
5	16-bits BCD	0,01Hz/LSB (1rpm/LSB)	100.0Hz																																																							
6	16-bits BCD	0,01%/LSB	99.99%																																																							
7	16-bits BCD	0,1%/LSB	100.0%																																																							
8	8-bits BCD	1/255%	100.0%																																																							
9	12-bits BCD	1/4095%	100.0%																																																							
10	16-bits BCD	1/65535%	100.0%																																																							
Parallel communications need option U2KV23PIO. Refer to instruction manual PCST-3303 for details																																																										

## 6. Control Functions and Parameter Settings

### Block-C parameters (H/W optional functions) list

No.	Parameter	Unit	Default	Min.	Max.	Function	Application																																																																											
							ST	V/f	VEC	PM																																																																								
<b>C33 – Sequence output function</b>																																																																																		
0	PSO4 Output		5.	0.	24.	These relay outputs can be provided by either of U2KV23RYO or U2KV23PIO optional interfaces	<input type="radio"/>																																																																											
1	PSO5 Output		6.	0.	24.		<input type="radio"/>																																																																											
<table border="1" style="width: 100%; border-collapse: collapse;"> <thead> <tr> <th>Value</th><th>Output signal</th> <th>Value</th><th>Output signal</th> <th>Value</th><th>Output signal</th> <th>Value</th><th>Output signal</th> </tr> </thead> <tbody> <tr><td>0</td><td>RUN</td><td>8</td><td>ATN</td><td>16</td><td>ACC</td><td>24</td><td>ULMT</td></tr> <tr><td>1</td><td>FLT</td><td>9</td><td>SPD1</td><td>17</td><td>DCC</td><td></td><td></td></tr> <tr><td>2</td><td>MC</td><td>10</td><td>SPD2</td><td>18</td><td>AUXDV</td><td></td><td></td></tr> <tr><td>3</td><td>RDY1</td><td>11</td><td>COP</td><td>19</td><td>ALM</td><td></td><td></td></tr> <tr><td>4</td><td>RDY2</td><td>12</td><td>EC0</td><td>20</td><td>FAN</td><td></td><td></td></tr> <tr><td>5</td><td>LCL</td><td>13</td><td>EC1</td><td>21</td><td>ASW</td><td></td><td></td></tr> <tr><td>6</td><td>REV</td><td>14</td><td>EC2</td><td>22</td><td>ZSP</td><td></td><td></td></tr> <tr><td>7</td><td>IDET</td><td>15</td><td>EC3</td><td>23</td><td>LLMT</td><td></td><td></td></tr> </tbody> </table>											Value	Output signal	Value	Output signal	Value	Output signal	Value	Output signal	0	RUN	8	ATN	16	ACC	24	ULMT	1	FLT	9	SPD1	17	DCC			2	MC	10	SPD2	18	AUXDV			3	RDY1	11	COP	19	ALM			4	RDY2	12	EC0	20	FAN			5	LCL	13	EC1	21	ASW			6	REV	14	EC2	22	ZSP			7	IDET	15	EC3	23	LLMT		
Value	Output signal	Value	Output signal	Value	Output signal	Value	Output signal																																																																											
0	RUN	8	ATN	16	ACC	24	ULMT																																																																											
1	FLT	9	SPD1	17	DCC																																																																													
2	MC	10	SPD2	18	AUXDV																																																																													
3	RDY1	11	COP	19	ALM																																																																													
4	RDY2	12	EC0	20	FAN																																																																													
5	LCL	13	EC1	21	ASW																																																																													
6	REV	14	EC2	22	ZSP																																																																													
7	IDET	15	EC3	23	LLMT																																																																													
<b>C34 – Serial interface</b>																																																																																		
0	Baud rate (bps)		1.	1.	6.	= 1: 300      = 4: 2400 = 2: 600      = 5: 4800 = 3: 1200     = 6: 9600	<input type="radio"/>																																																																											
1	Transmission system		1.	1.	2.	= 1: 1: 1      = 2: 1: N	<input type="radio"/>																																																																											
2	Pariry check		1.	1.	3.	=1: None, =2: Even, =3: Odd	<input type="radio"/>																																																																											
3	Parameter setting protection		1.	1.	5.	The parameters are shown in below table	<input type="radio"/>																																																																											
<table border="1" style="width: 100%; border-collapse: collapse;"> <thead> <tr> <th rowspan="2">Setting value</th> <th rowspan="2">Block A</th> <th colspan="4">Block B, C</th> </tr> <tr> <th>Basic</th> <th>Ex-tend</th> <th>S/W</th> <th>H/W</th> </tr> </thead> <tbody> <tr><td>1</td><td><input type="radio"/></td><td><input type="radio"/></td><td><input type="radio"/></td><td><input type="radio"/></td><td><input type="radio"/></td></tr> <tr><td>2</td><td>X</td><td>X</td><td>X</td><td>X</td><td>X</td></tr> <tr><td>3</td><td><input type="radio"/></td><td>X</td><td>X</td><td>X</td><td>X</td></tr> <tr><td>4</td><td><input type="radio"/></td><td>X</td><td><input type="radio"/></td><td>X</td><td>X</td></tr> <tr><td>5</td><td><input type="radio"/></td><td>X</td><td><input type="radio"/></td><td><input type="radio"/></td><td>X</td></tr> </tbody> </table> <p style="text-align: center;">O: Changeable    X: Lock</p>											Setting value	Block A	Block B, C				Basic	Ex-tend	S/W	H/W	1	<input type="radio"/>	<input type="radio"/>	<input type="radio"/>	<input type="radio"/>	<input type="radio"/>	2	X	X	X	X	X	3	<input type="radio"/>	X	X	X	X	4	<input type="radio"/>	X	<input type="radio"/>	X	X	5	<input type="radio"/>	X	<input type="radio"/>	<input type="radio"/>	X																																
Setting value	Block A	Block B, C																																																																																
		Basic	Ex-tend	S/W	H/W																																																																													
1	<input type="radio"/>	<input type="radio"/>	<input type="radio"/>	<input type="radio"/>	<input type="radio"/>																																																																													
2	X	X	X	X	X																																																																													
3	<input type="radio"/>	X	X	X	X																																																																													
4	<input type="radio"/>	X	<input type="radio"/>	X	X																																																																													
5	<input type="radio"/>	X	<input type="radio"/>	<input type="radio"/>	X																																																																													
4	Station No.		1.	0.	32.	Set the local station number	<input type="radio"/>																																																																											
5	Response timer	sec.	0.00	0.00	2.00	Set the minimum time for returning an answer after receiving a command	<input type="radio"/>																																																																											
This serial comm. needs option card U2KV23SLO. Refer to instruction manual PCST-3304 for other details																																																																																		
<b>C35 – Profibus Interface</b>																																																																																		
0	Station number		1.	1.	126.		<input type="radio"/>																																																																											
1	Transmission error detection		1.	2.	2.	= 1: Detection error disabled = 2: Detection error enabled	<input type="radio"/>																																																																											

## 6. Control Functions and Parameter Settings

### Block-C parameters (H/W optional functions) list

No.	Parameter	Unit	Default	Min.	Max.	Function	Application				
							ST	V/f	VEC	PM	
<b>C50 – Encoder setting</b>											
0	Encoder pulse divided output		4.	1.	1024.	The pulses received from the encoder can be divided and output through PAOUT and PBOUT				○	
1	Encoder output pulse type selection		1.	1.	2.	= 1: 2-phase input = 2: 1-phase input In vector control with sensor mode, set this parameter and B01-8 as well				○	
2	Encoder ABZ pulse type selection		0.	0.	15.	Set values according following table				○	○

Setting No.	A-IN Direct/ Inverse	B-IN Direct/ Inverse	Z-IN Direct/ Inverse	AB inter-change	Setting No.	A-IN Direct/ Inverse	B-IN Direct/ Inverse	Z-IN Direct/ Inverse	AB inter-change
0	Direct	Direct	Direct	No inter-change	8	Direct	Direct	Direct	AB inter-change
1	Inverse	Direct	Direct						
2	Direct	Inverse	Direct						
3	Inverse	Inverse	Direct						
4	Direct	Direct	Inverse						
5	Inverse	Direct	Inverse						
6	Direct	Inverse	Inverse						
7	Inverse	Inverse	Inverse						
8	Direct	Direct	Direct		9	Inverse	Direct	Direct	
					10	Direct	Inverse	Direct	
					11	Inverse	Inverse	Direct	
					12	Direct	Direct	Inverse	
					13	Inverse	Direct	Inverse	
					14	Direct	Inverse	Inverse	
					15	Inverse	Inverse	Inverse	

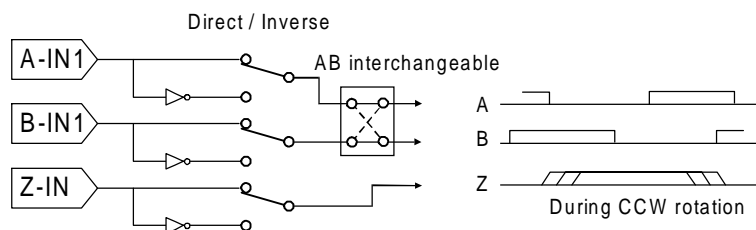

#### C51 – Encoder setting (PM)

0	Encoder UVW pulse type selection	-	0	0	7.	Set a value according the table shown below					○
1	Z phase → U phase winding phase angle	deg	0.0	0.0	359.9	Electrical angle from Z phase to U winding					○
2	Z phase → U phase signal phase angle	deg	0.0	0.0	359.9	Electrical angle from Z phase to U signal					○

Setting No.	U-IN Direct/ Inverse	V-IN Direct/ Inverse	W-IN Direct/ Inverse	UV inter-change
0	Direct	Direct	Direct	No inter-change
1	Inverse	Direct	Direct	
2	Direct	Inverse	Direct	
3	Inverse	Inverse	Direct	
4	Direct	Direct	Inverse	
5	Inverse	Direct	Inverse	
6	Direct	Inverse	Inverse	
7	Inverse	Inverse	Inverse	

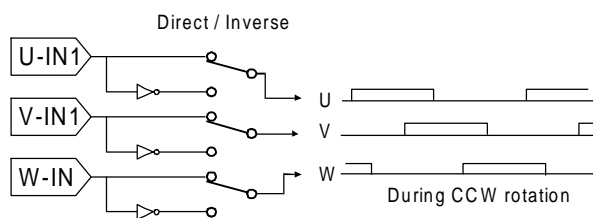

6-5 Block-U Parameters

Block-U parameters (Utility mode) list

No.	Parameter	Unit	Default	Min.	Max.	Function	Application			
							ST	V/f	VEC	PM
<b>U00 – Parameter Control</b>										
0	Parameter Copy function		0.	0.	9999.	= 1001: Save The data is saved from inverter to operation panel = 2002: Load The data is loaded from operation panel to inverter = 3003: Verify check Verification of inverter and Operation panel data = 4004: Clear Data of operation panel is cleaned	○			

6-6 Function explanation

- A00-0 Local frequency setting
- A00-2 Local speed setting

This is the frequency (or speed) setting used in the local mode (operation control from the operation panel when it is enabled, "LCL" LED ON-.

The output frequency (speed) changes immediately according to the  operation. Refer to section 5-9-1 for details on selecting the speed setting.

- A00-1 Frequency setting for jogging
- A00-3 Speed setting for jogging

This is the frequency (speed) setting selected when executing jogging run through the sequence command F JOG or R JOG.

An acceleration/deceleration time exclusive for jogging can be set with B10-2 and B10-3.

B10-2: Acceleration ramp time for jogging

B10-3: Deceleration ramp time for jogging

- A01-0, 1 Acceleration/deceleration times
- A03-0, 1 DC brake
- C01-0, 1 Start/stop frequency

(V/f control: C30-0 = 1, 2)

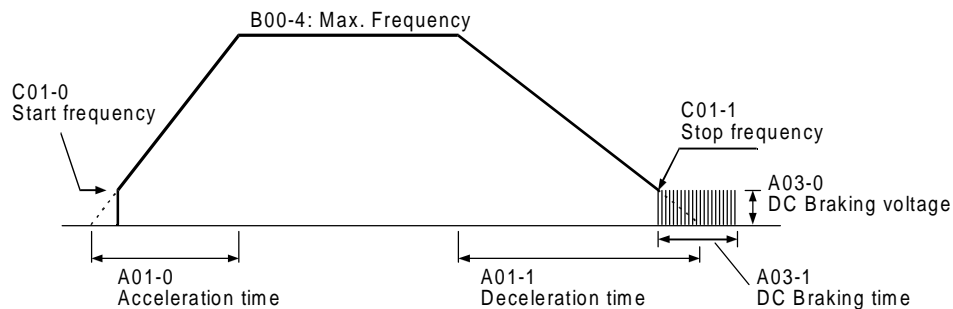

This is the acceleration/deceleration ramp time validated during normal use (when sequence command CSEL is OFF). The inverter may trip if the set time is too short.

Increase the DC braking voltage in units of 1% or less at a time while monitoring the output current. The inverter may trip if the setting is too high.

**(Note)** The DC braking voltage is automatically adjusted by the Autotuning function

(IM Vector control: C30-0 = 3, 4), or (PM motor control: C30-0=5)

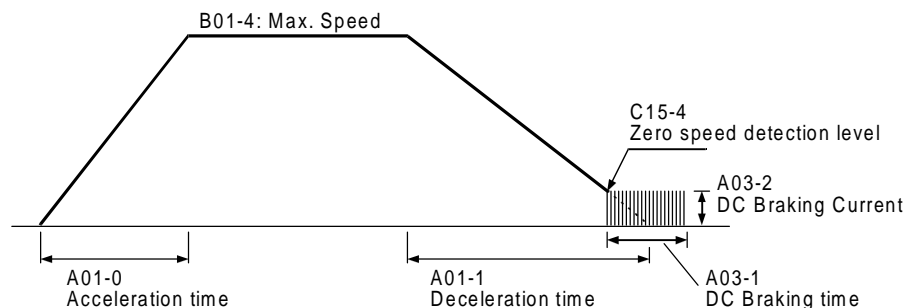

**A02-0**

**Manual torque boost selection**

This setting allows increase the torque at low speed for V/f control. When manual torque boost is enabled, this will be valid regardless of the automatic torque boost selection state.

**A02-1**

**Automatic torque boost selection**

The automatic torque boost optimises the V/f control. The functions R1 drop compensation, slip compensation and maximum torque boost functions will be enabled.

**(Note 1)** Is possible to validate only the slip compensation function when manual torque boost is selected, setting the slip compensation function (A02-5). All other parameters (A02-3, 4, 6) should be set to 0.

**(Note 2)** The square reduction torque setting, for quadratic loads, is always valid regardless of the torque boost selection state. To invalidate the square reduction torque setting, set (A02-3) to 0.

**Torque boost selection block diagram (V/f control)**

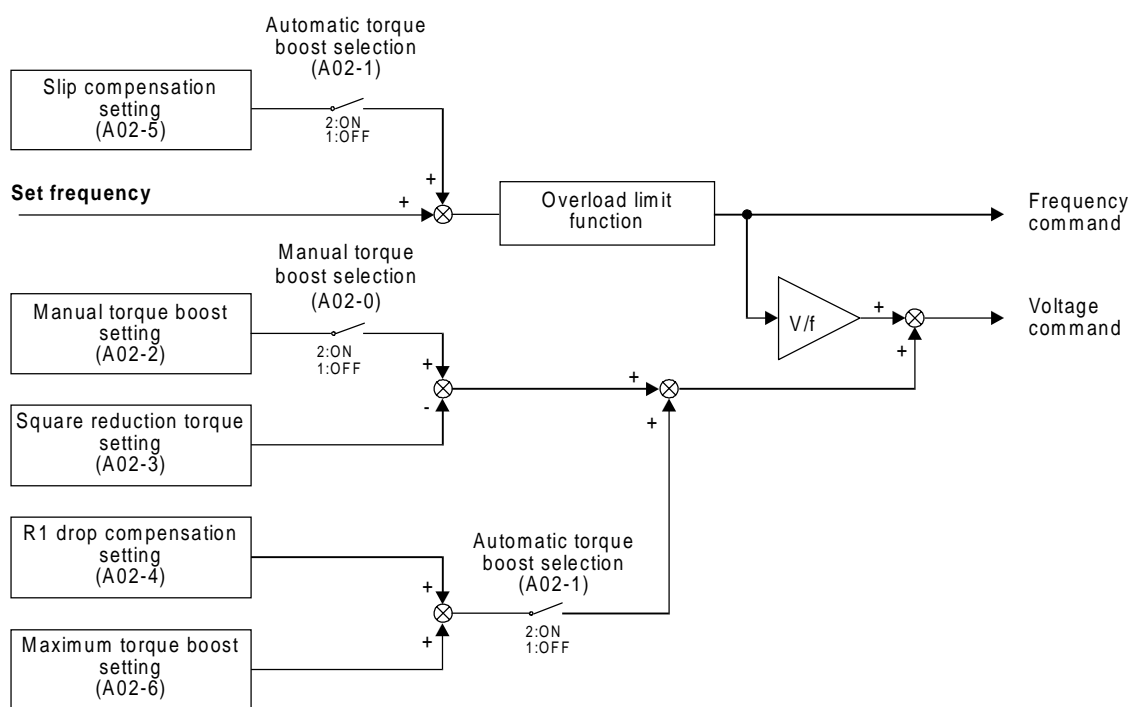

### • Automatic torque boost function (V/f improved control)

The automatic torque boost function controls voltage boosting and slip compensation using the current detection value. This allows to improve the motor torque when starting and at the low speed regions. Critical parameters which performs the automatic torque boost function, will be automatically adjusted by the Auto-tuning function, allowing that a standard AC motor outputs up to 200% or more starting torque with 150% current.

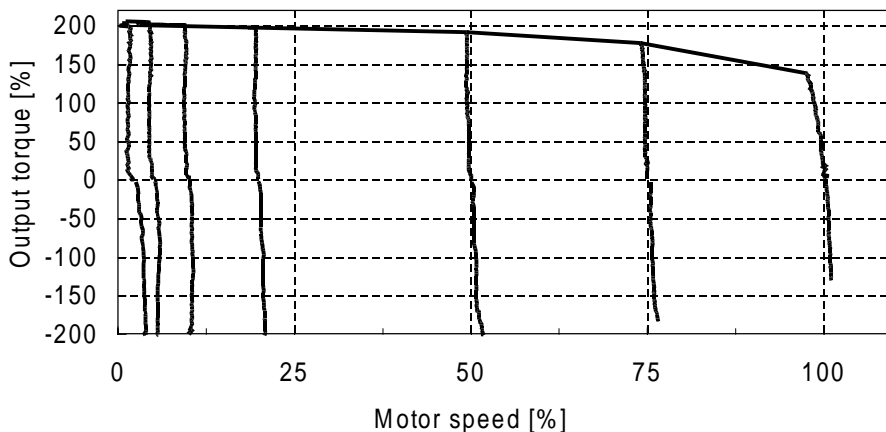

< standard 3-phase induction motor 1.5kW-4P >

#### CAUTION

- Even using only manual torque boost, carry out automatic tuning (B19-0 = 1).
- When using automatic torque boost, always carry out automatic tuning (B19-0 = 2).
- The maximum torque is not output instantly. It takes approx. 3 seconds for the maximum torque to be reached.
- If the motor vibrates abnormally, etc. during Auto-tuning, cancel it and adjust the drive manually.
- If the parameters are with set manually, the motor rotation could become unstable.
- Special motors which the base frequency greatly exceeds the commercial frequency, or motors with a large constant voltage range, the rotation may be unstable and torque may not be sufficient.
- Check motor temperature if the application requires high torque for a long time

#### A02-2

### Manual torque boost setting [%]

This parameter is automatically set by automatic tuning (V/f control mode). When setting manually, set the boost voltage at 0Hz as a percentage in respect to the rated output voltage (B00-3).

**A02-3**

**Square reduction torque setting [%]**

Set the reduction torque at the base frequency (B00-5)/2 as a percentage in respect to the rated output voltage (B00-3)

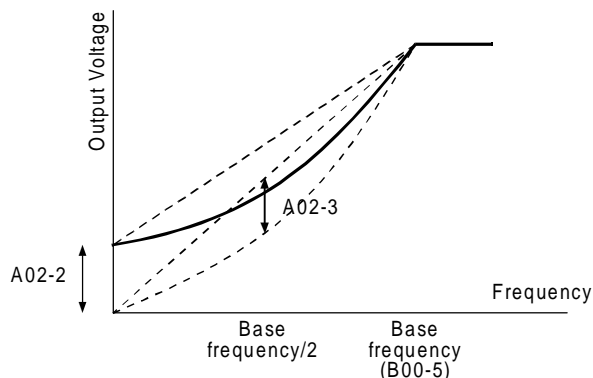

**(Note)** When both A02-2 and A02-3 are set, the voltage will be added as shown above.

**A02-4**

**R1 drop compensation gain [%]**

This setting compensates the voltage drop caused by R1. Normally set to 50%. The motor primary resistance R1 must be properly adjusted by the Auto-tuning.

**(Note 1)** If set too high, the rotation become unstable and the drive may trip.

**(Note 2)** If set too low, the torque may not be sufficient.

**A02-5**

**Slip compensation gain [%]**

This is automatically set by automatic tuning.

When setting manually, set the slip frequency for the motor rated load as a percentage in respect to the base frequency (B00-5).

The output frequency changes according to the motor rated torque as shown below.

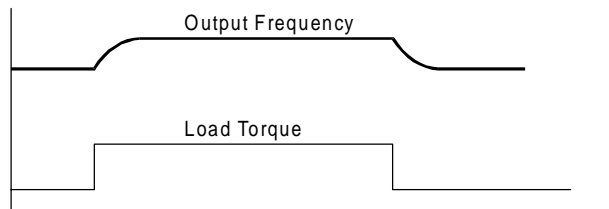

**(Note 1)** The slip compensation will not function in respect to the regenerative torque.

**(Note 2)** The output frequency will respond with a time constant of approx. 500ms in respect to the changes in the load torque.

**(Note 3)** When set too high, the motor rotation could become unstable.

**A02-6**

**Maximum torque boost gain [%]**

This is automatically set by automatic tuning.

The optimum boost value for outputting the maximum torque is set as a percentage in respect to the rated output voltage (B00-3).

Normally, a value of 10 to 30% is set by automatic tuning.

**(Note 1)** When adjusted manually, the sufficient torque may not be attained.

**(Note 2)** If set too high, the rotation may become unstable and may trip.

**A04-0~7 Custom parameters**

C10-0~7: Allow selection of custom parameters. Refer to section 4-7 for details.

**A05-0~2 Block B, C parameter skip**

These parameter allows selection of parameters to be displayed. Unnecessary displays can be reduced with this parameter, allowing easier operation. All displays are set to skip as the default.

**A10-0 ASR response**

This parameter is used to calculate the gain of the ASR.

ASR gain :

$$K_p = \text{ASR response (A10-0) [rad/s]} \times \frac{\text{Machine time constant (A10-1 or B15-0) [ms]}}{1000}$$

ASR integral time constant :

$$T_i = \frac{4}{\text{ASR response (A10-0) [rad/s]}} \times \frac{\text{Compensation coefficient (A10-2) [%]}}{100}$$

**A10-1 Machine constant – 1**

This is used to calculate the ASR gain. This is valid when the sequence input machine time constant changeover is OFF (MCH = OFF).

$$T_M [s] = \frac{GD^2 [kgm^2] \times 1.027 \times (N_{base} [min^{-1}])^2}{375 \times \text{Power [W]}}$$

$T_M$  : Machine time constant  
 $GD^2$  : Total inertia load and motor  
 $N_{base}$ : Base speed  
 Power: Motor rated output

- A10-3 ASR drive torque limit**
- A10-4 ASR regenerative torque limit**
- A10-5 Emergency stop regenerative torque limit**
- A11-2 ACR drive torque limit**
- A11-3 ACR regenerative torque limit**

The output current is limited by the overcurrent limit value (B18-0). To generate motor torque set a value larger than the value given in below expression. .

$$\frac{\sqrt{(\text{Exciting current})^2 \times (\text{Torque current})^2}}{\text{Motor rated current (B01-6)}} \times 100 \leq B18-0$$

B00-7
-------

### Carrier frequency

B01-7
-------

The PWM carrier frequency and control method can be changed to change the tone of the magnetic sound generated from the motor. The relation of the setting range and control method is shown below.

1) For drives up to U2KN37K0S or U2KX45K0S

- 1.0 to 15.0 : Mono sound method (Actual carrier frequency: 1.0 to 15.0kHz)
- 15.1 to 18.0 : Soft sound method 1 (Basic carrier frequency: 2.1 to 5.0kHz)
- 18.1 to 21.0 : Soft sound method 2 (Basic carrier frequency: 2.1 to 5.0kHz)

1) For drives larger than U2KX45K0S, (from U2KX45K0S to U2KX315KS)

- 1.0 to 8.0 : Mono sound method (Actual carrier frequency: 1.0 to 8.0kHz)
- 8.1 to 11.0 : Soft sound method 1 (Basic carrier frequency: 2.1 to 5.0kHz)
- 11.1 to 14.0 : Soft sound method 2 (Basic carrier frequency: 2.1 to 5.0kHz)

#### [Mono sound method]

This control method has a constant PWM carrier frequency. When a low carrier frequency is set, an annoying magnetic sound may be generated.

#### [Soft sound method]

This control method changes the PWM carrier frequency at a fixed cycle, producing a softer sound and lower electrical noise than the mono-sound method..

- (Note 1)** There are cases when the setting value and actual carrier frequency (reference carrier frequency for soft sound method) differ. Confirm the actual carrier frequency with D03-3.
- (Note 2)** In some cases the effect of noise onto the inverter's peripheral devices can be reduced by lowering the carrier frequency.
- (Note 3)** If set to higher than the specified carrier frequency, the output current must be derated. Refer to Fig. 1-2 in Appendix 1 for details.
- (Note 4)** If the heat sink temperature 70°C is exceeded and the output current exceeds 90%, the carrier frequency will automatically change to 4kHz.

**B02-0~9**

**Motor circuit constant (IM)**

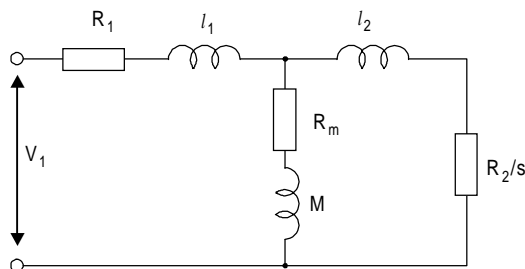

**T-type equivalence circuit**

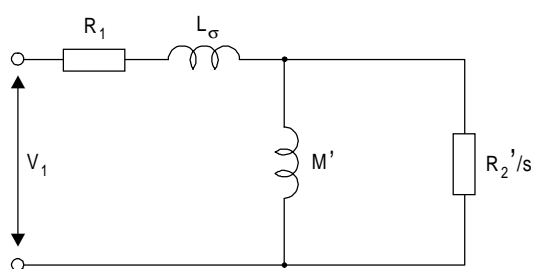

**T-I type equivalence circuit**

$$M' = M^2 / (l_2 + M)$$

$$L\sigma = (l_1 + M) - M^2 / (l_2 + M)$$

$$R_2' = (M / (l_2 + M))^2 \cdot R_2$$

**B03-0~4**

**Motor circuit constant (PM)**

Parameter related to Permaent Magnet motor control

**B05-0~5**

**Frequency skip**

By setting this parameter, the motor's mechanical resonance point at a specific frequency can be skipped.

Valid only during V/f control (C30-0 = 1, 2).

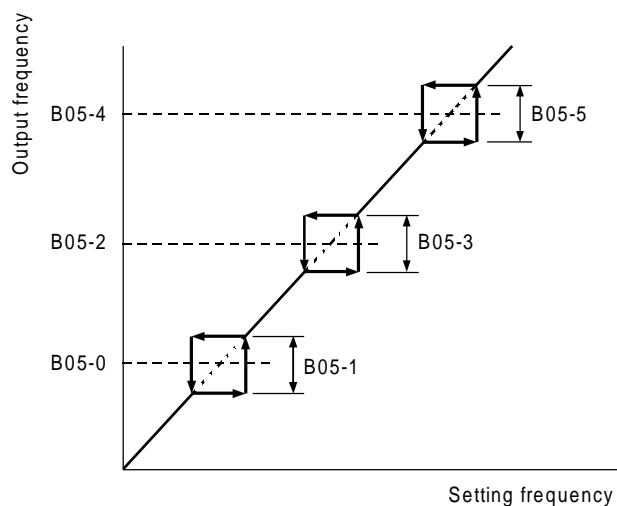

**(Note)** This function controls the frequency setting, so the above skip frequency area will be passed with a ramp function.

**B06-0~6** Ratio interlock setting

The ratio interlock operation executes the following expression and corresponds to each speed setting input signal.

- $Y = AX + B + C$
- X: Frequency (speed) setting input
  - Y: Frequency (speed) command (operation results)
  - A: Coefficient (B06-0)
  - B: Bias (B06-1, 4 where B'' = 0)
  - C: Bias (C07-3)

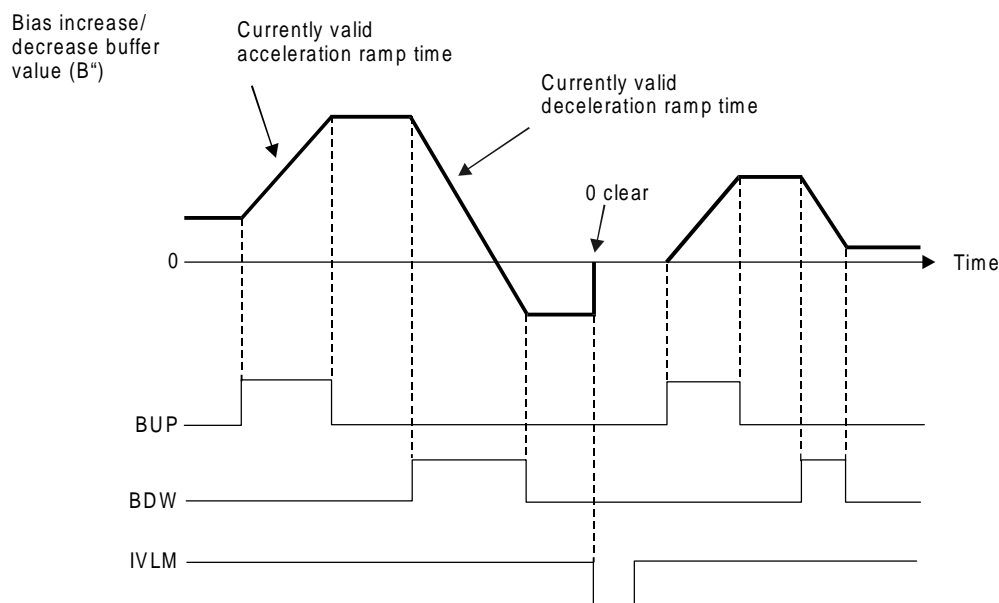
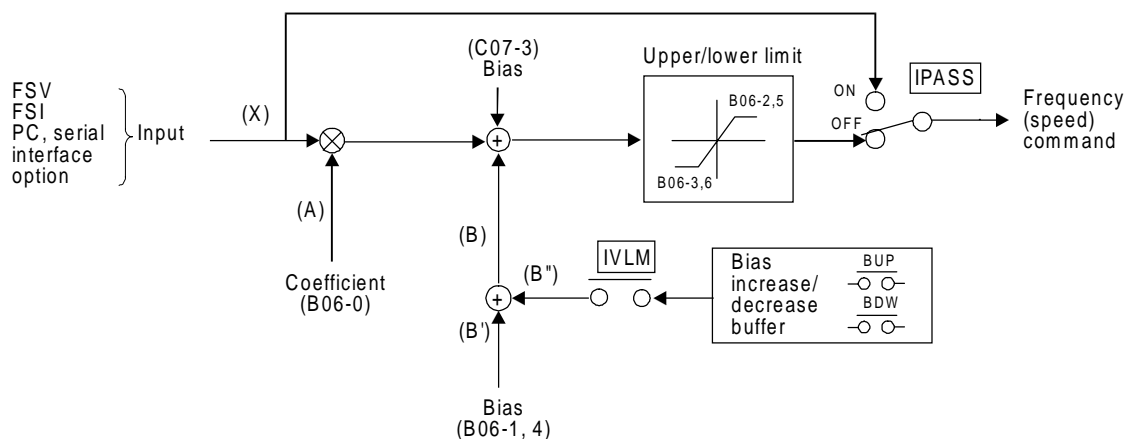

**(Ratio interlock bias increase/decrease function)**

When IVLM turns ON, it is possible to increase/decrease the bias (B''), by BUP and BDW functions. This bias is added to the ratio interlock bias value (B')

If BUP turns ON while IVLM is ON, the bias buffer (B'') increases its value with the currently valid acceleration ramp rate. When BDW turns ON, the bias buffer (B'') decreases its value with the currently valid deceleration ramp rate.

If both BUP and BDW turn OFF while IVLM is ON, the current bias buffer value (B'') is held.

If IVLM turns OFF, the current bias buffer value (B'') is cleared to zero, and the BUP and BDW operations are ignored.

If the operation command (RUN) turns OFF, the current bias buffer value (B'') is cleared to zero. The BUP and BDW operations are also ignored in this case.

B10-0	Acceleration ramp time –2
B10-1	Deceleration ramp time –2
B10-2	Acceleration ramp time for jogging
B10-3	Deceleration ramp time for jogging

The ramp up/down time can be switched by turning the sequence command CSEL to ON. Set the CSEL command input terminal with C03-6 parameter. The ramp time for jogging can be set independently with B10-2 and -3.

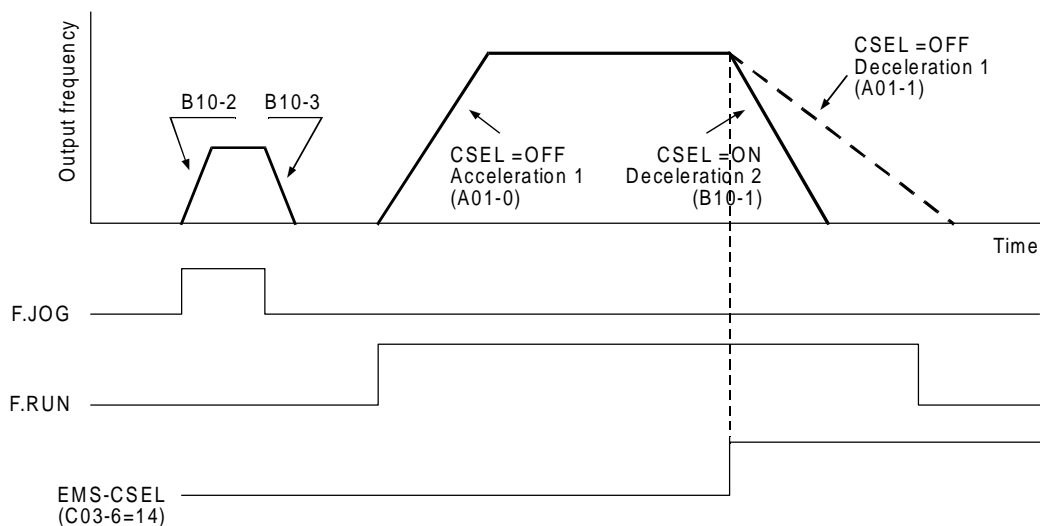

The above run example shows the case when the sequence command CSEL is connected to the EMS terminal (C03-6=14), and the run is decelerated with ramp down time –2 during emergency stop.

**(Note)** The acceleration or deceleration ramp time set, is the time to reach maximum frequency (B00-4) or maximum speed (B01-4) from zero, or the opposite.

**B10-4**

**S-shape characteristics**

Acceleration/deceleration with the S-shape pattern is possible by setting this parameter.

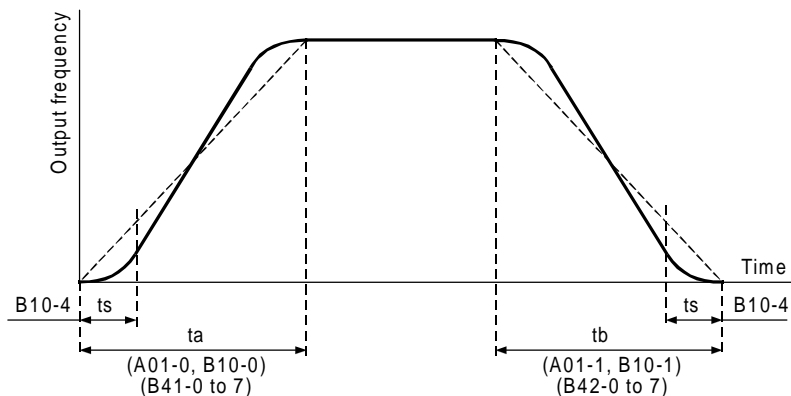

This parameter indicates the time of the section shown as "ts" above.

The total acceleration/deceleration times ta and tb will not change.

When this parameter is set, all the acceleration and deceleration ramps available in the VAT2000 will be S-type.

**(Note)** Set so that the relation of the B10-4 setting and acceleration/deceleration time is as shown below.

$$\text{B10-4 Setting value (ts)} \times 2 \leq \text{acceleration/deceleration time (ta, tb)}$$

**B10-5**

**Time unit multiplier**

The acceleration/deceleration time setting unit can be changed when an acceleration/deceleration time in a wider range is to be set.

B10-5 = 1 (standard)	: × 1
2	: × 0.1
3	: × 10

This parameter will affect all acceleration/deceleration time parameters.

**B11-0~7**  
**B11-8**

**Program frequency (speed) setting**  
**Selection mode setting**

Up to eight fixed output frequencies or speed are allowed when PROG function is enabled. Set desired frequencies or speed to parameters B11-0 to B11-7, in percentage of maximum output (B00-4) and (B01-4). Selection of speeds or frequencies are done through auxiliary functions S0, S1, S2, S3, and SE, as shown in below table.

(1) For binary selection mode (B11-8=1)

Sequence command					Selected frequency
SE	S3	S2	S1	S0	
*	*	OFF	OFF	OFF	B11-0
		OFF	OFF	ON	B11-1
		OFF	ON	OFF	B11-2
		OFF	ON	ON	B11-3
		ON	OFF	OFF	B11-4
		ON	OFF	ON	B11-5
		ON	ON	OFF	B11-6
		ON	ON	ON	B11-7

\* : SE and S3 are not used.

(1) For direct selection mode (B11-8=2)

Sequence command					Selected frequency
SE	S3	S2	S1	S0	
OFF	OFF	OFF	OFF	OFF	Latest value
OFF	OFF	OFF	OFF	ON	B11-0
OFF	OFF	OFF	ON	OFF	B11-1
OFF	OFF	ON	OFF	OFF	B11-2
OFF	ON	OFF	OFF	OFF	B11-3
ON	OFF	OFF	OFF	OFF	Latest value
ON	OFF	OFF	OFF	ON	B11-4
ON	OFF	OFF	ON	OFF	B11-5
ON	OFF	ON	OFF	OFF	B11-6
ON	ON	OFF	OFF	OFF	B11-7

When S0 to S3 are all OFF the latest frequency set value is hold. After power ON the latest value is cleared to "0"

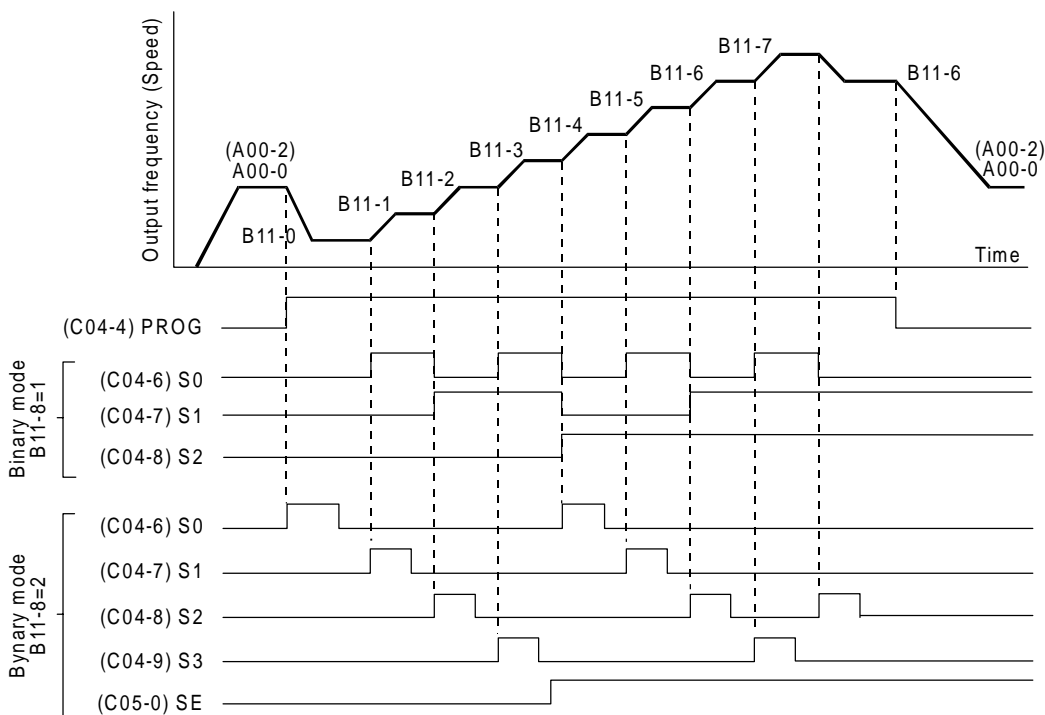

**Program run example**  
**(When command RUN is ON)**

Set the PROG command input terminal with C04-4. Set the S0, S1, S2, S3 and SE input terminals with C04-6~C05-0.

**B13-0**

**Torque setting**

Refer to section 5-9-2 for details on selecting the torque setting.

**B13-1**

**Torque ratio 1 setting**

Refer to section 5-9-5 for details on selecting the torque ratio 1 setting.

**B13-2**

**Torque bias 1 setting**

Refer to section 5-9-3 for details on selecting the torque bias 1 setting.

**B13-3**

**Torque ratio 2 setting**

Refer to section 5-9-6 for details on selecting the torque ratio 2 setting.

**B13-4**

**Double rating speed ratio setting**

Refer to section 5-9-4 for details.

**B13-5**

**Drooping setting**

Set the drooping value within the range of the following expression. If it becomes unstable, adjust the drooping setting value or the related parameters.

$$\frac{\text{Drooping setting value (B13-5) [\%]}}{100 [\%]} \times \text{ASR response (A10-0) [rad/s]} \times \frac{\text{Machine time constant (A10-1 or B15-0) [ms]}}{1000} < 0.5$$

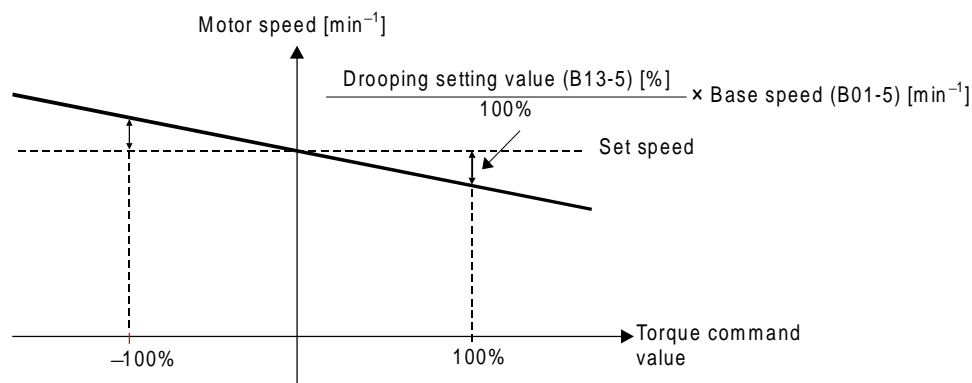

**B13-6**

**ASR gain compensation in constant power range**

**B13-7**

**ACR gain compensation in constant power range**

Increase or decrease each ASR gain and ACR gain in power constant speed range.

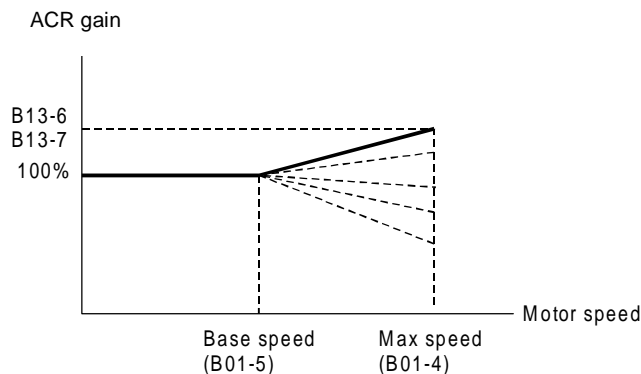

**B14-0**

**ASR dead band setting**

Refer to Fig. 5-1 for details.

**B15-0**

**Machine time constant 2**

This is used to calculate the ASR gain. This is valid when the sequence input machine time constant changeover is ON (MCH = ON).

$$TM [s] = \frac{GD^2 [kgm^2] * 1.027 * (Nbase [min^{-1}])^2}{375 * Power [W]}$$

TM : Machine time constant  
 GD<sup>2</sup> : Total inertia of motor and load  
 Nbase : Base speed  
 Power : Motor rated output

**B17-0~3**

**V/f middle point**

A V/f characteristic as shown on the right can be obtained for motors having special V/f characteristics.

**(Note)**

Set so that  $F1 \leq F2 \leq$  Base frequency (B00-5) and  $V1 \leq 2$ .

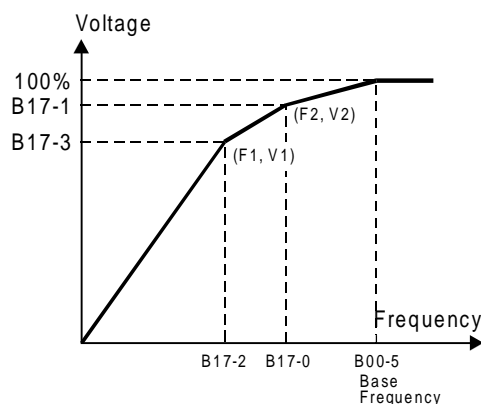

B18-0
B18-1,2
B18-3
B18-4
B18-5
B18-6

**Over current limit**

Check next page

**Over current limit gain**

**Current stabilisation gain**

**Over current breakdown prevention gain**

**Over current stall prevention time constant**

The over current limit is a function that lowers the output frequency and suppresses the current so that the motor current does not exceed this parameter setting value during starting or constant running. The setting uses the motor rated current (B00-6) as 100%. Normally, set the default value (150%).

**(Note)** Set a value larger than the motor no-load current.

The overcurrent limit function is configured of the following three control blocks.

**(1) Overcurrent vector limit function**

This uses the overcurrent as a vector, and generates a suppressing voltage vector instantly to suppress the current. The response is adjusted with the overcurrent limit gain (B18-3).

Normally, set the default value (0.25).

If the setting value is increased, the response will become faster, but the operation may become unstable.

**(2) Current stabilisation control**

This suppresses the sudden changes during overcurrent suppression by controlling the output frequency. The response is adjusted with the over current stabilisation gain (B18-4).

Normally, set the default value (0.25).

If the setting value is increased, the torque vibration will be reduced, but the operation may become unstable.

**(3) Frequency compensation control**

This feeds back the voltage suppressed with the overcurrent vector limit function to the frequency command and prevents breakdown. The response is adjusted with the over current stall prevention gain (B18-5) and over current stall prevention time constant (B18-6). Normally, set the default value (B18-5 = 1.0, B18-6 = 100). If the gain setting value (B18-5) is increased or the time constant value (B18-6) is decreased, the response will become faster, but the operation may become unstable.

**(Note)** The overcurrent limit function is valid at all times regardless of whether automatic tuning has been executed.

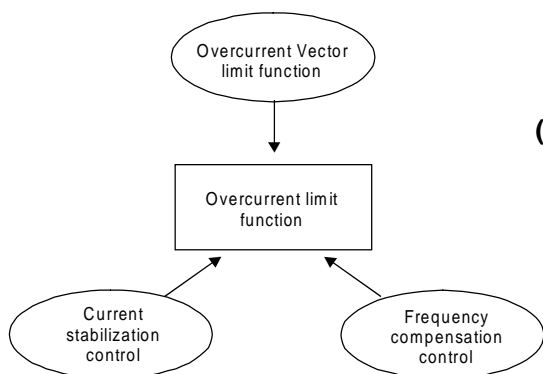

**B18-1**

### Regenerative current limit

The regenerative torque to deceleration running is limited. Set to 10% when not using the DBR option. When using the DBR option, calculate the value with the following formula and set.

$$\text{B18-1 setting value} = \left[ \left( \frac{V2}{\text{DBR resistance value}} \right) / \text{Motor capacity [kW]} \right] \times 100 [\%]$$

where V2=148.2 for the 200V system and V2=593 for the 400V system.

**B18-2**

### Torque stabilisation gain

This function suppresses the hunting phenomenon that causes the current to abnormally vibrate during motor operation.

Normally, the specified value (1.00) is set, and the setting value is increased appropriately according to the hunting.

Note that the hunting phenomenon occurs easily in the following cases.

- During a light load or no load
- When the system inertia is low
- When the motor's secondary time constant is high (high-efficiency motor)
- When carrier frequency is high

**(Note)** The hunting phenomenon at a frequency exceeding 66Hz cannot be suppressed.

**B35-0**

### Demagnetising control operating voltage

**B35-1**

### Demagnetising current limit value

**B35-2**

### Demagnetising current control proportional gain

**B35-3**

### Demagnetising current control integral time constant

**B35-4**

### Flux temperature compensation range

**B35-5**

### Flux temperature compensation time constant

**B36-0 to  
4**

### Demagnetising current table 0 to 4

All these above mentioned parameters are related to PM Motor control. Please check the manual PCST3307 of the optional encoder interface for PM motors, type U2KV23DN3.

**B40-0~1**

### Software option functions

The program ramps, pattern operation, traverse, PID and multi-pump functions can be selected with parameters B40-0 and B40-1, as shown below. (use only one at a time)

B40-0 = 1: All software functions are disabled  
 2: Program ramp function (B41-0 to B42-7)  
 3: Pattern run function (B50-0 to B59-3)  
 4: Traverse function (B45-0 to B45-6)

B40-1 = 1: All software functions are disabled  
 2: PID (B43-0 to B43-4)  
 3: Multipump (B43-0 to B44-3)

**B41-0~7**  
**B42-0~7**

**Program ramp – acceleration**

**Program ramp – deceleration**

The motor can be run with up to eight program frequency (speed) using the sequence commands PROG and S0, S1, S2, S3, SE. The program ramp time can also be switched at this time allowing individual acceleration or deceleration ramp for each speed.

If PROG is OFF, the program ramp time can be changed with S0, S1, S2, S3 and SE.

The ramp time selected with S0, S1, S2, S3 and SE is as shown below.

**(1) For binary selection mode (B11-8=1) (1) For direct selection mode (B11-8=2)**

Sequence command					Selected ramp time
SE	S3	S2	S1	S0	
*	*	OFF	OFF	OFF	B41-0 B42-0
		OFF	OFF	ON	B41-1 B42-1
		OFF	ON	OFF	B41-2 B42-2
		OFF	ON	ON	B41-3 B42-3
		ON	OFF	OFF	B41-4 B42-4
		ON	OFF	ON	B41-5 B42-5
		ON	ON	OFF	B41-6 B42-6
		ON	ON	ON	B41-7 B42-7

\* : SE and S3 are not used.

Sequence command					Selected ramp time
SE	S3	S2	S1	S0	
OFF	OFF	OFF	OFF	OFF	Latest value
OFF	OFF	OFF	OFF	ON	B41-0 B42-0
OFF	OFF	OFF	ON	OFF	B41-1 B42-1
OFF	OFF	ON	OFF	OFF	B41-2 B42-2
OFF	ON	OFF	OFF	OFF	B41-3 B42-3
ON	OFF	OFF	OFF	OFF	Latest value
ON	OFF	OFF	OFF	ON	B41-4 B42-4
ON	OFF	OFF	ON	OFF	B41-5 B42-5
ON	OFF	ON	OFF	OFF	B41-6 B42-6
ON	ON	OFF	OFF	OFF	B41-7 B42-7

When S0 to S3 are all OFF the latest ramp time set value is hold. After power ON the latest value is cleared to "0"

An example of combination with the program frequency (speed) setting is shown below.

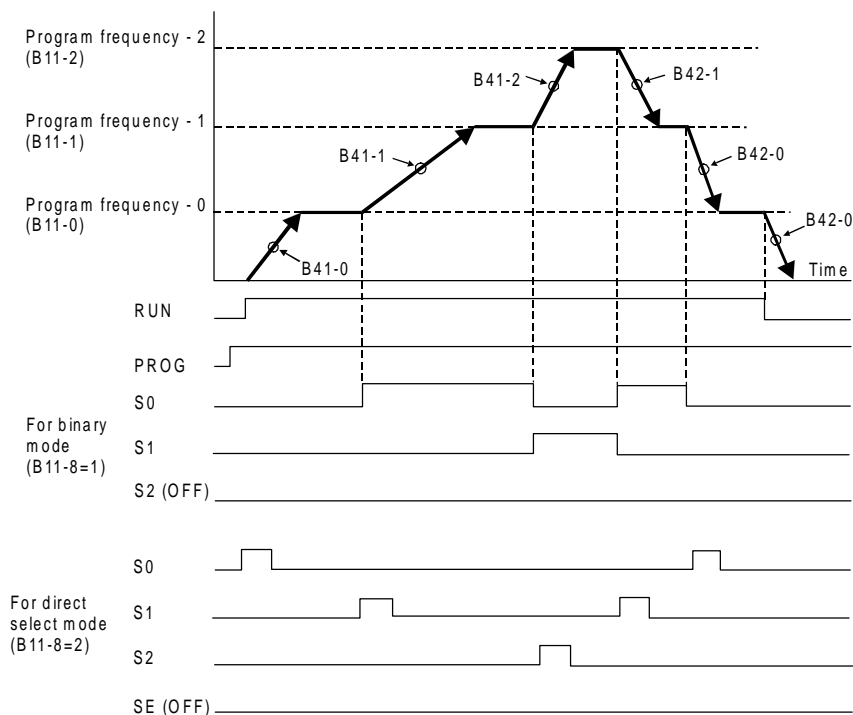

**(Note)** The acceleration/deceleration ramp time-2 (B10-0, 1) will be selected by turning the sequence command CSEL ON even when using the program ramp (B40-0=2).

**B43-0~4**

### PID control

The analog input (FSV, FSI, AUX) can be configured as a feedback loop as shown below. The below is an example. It is possible to use any analog input either as setting or feedback.

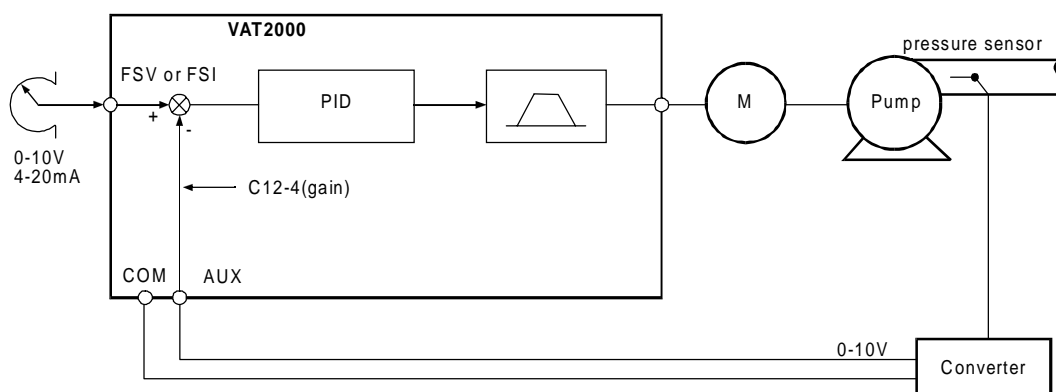

**Example of PID control configuration**

**(Note 1)** PID control functions only in the remote mode (LCL LED OFF)

**(Note 2)** PID control functions in respect to the sequence command FRUN or RRUN, but does not operate with other sequence commands like Jog for example

The PID operation block is shown below,

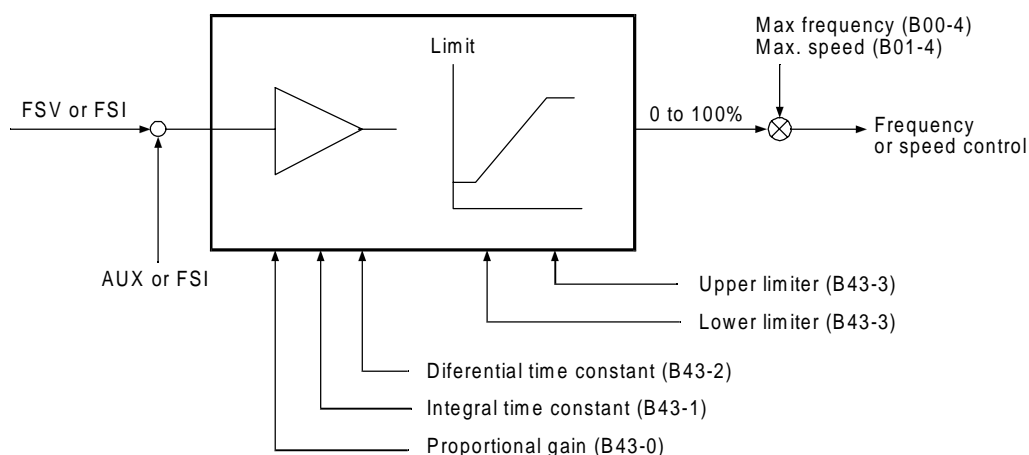

- (1) Is possible to enable or disable the PID control during operation by switching ON or OFF the sequence input function PIDEN. This can be controlled by one of the programmable digital inputs.
- (2) Refer to fig 5-9 and select the PID's setting input.
- (3) Set the analog input to be used as feedback with C07-5. Set the range of the selected analog input with block parameters C12.
- (4) If the feedback signals must be 4-20mA type, use FSI as feedback. However would be possible to use AUX for 4-20mA signals, setting C12-2=2 to fix AUX input in range of 1-5V, and then connect a external resistor of 250 Ohms, 1%, 1/2W, between AUX and COM terminals.

**B44-0~3**

**Multipump control**

Multi-pump control refers to operating up to six pumps in one water system, one pump is variable speed controlled and up to five more controlled ON/OFF by the digital outputs provided in the VAT2000. The water pressure in the pipe system is controlled to be constant according to the setting input in the VAT2000's PID.

As standard the drive provide control up to 3 ON/OFF controlled pumps. By using optional card U2KV23RYO, then operation is allowed up to 5 pumps

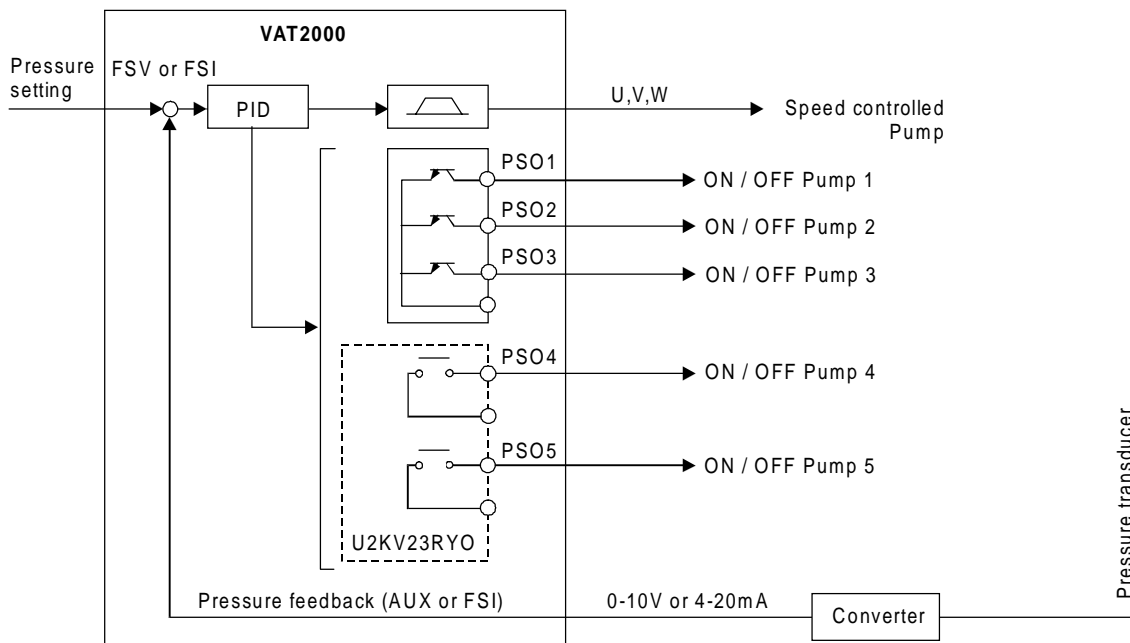

**Example of system configuration**  
(when operating five ON/OFF control pumps)

**Note:** PIDEN function (C03-8) must be activated for multipump control operation

### 1) Multipump control operation

An example of actual operation for the multipump control is shown below.

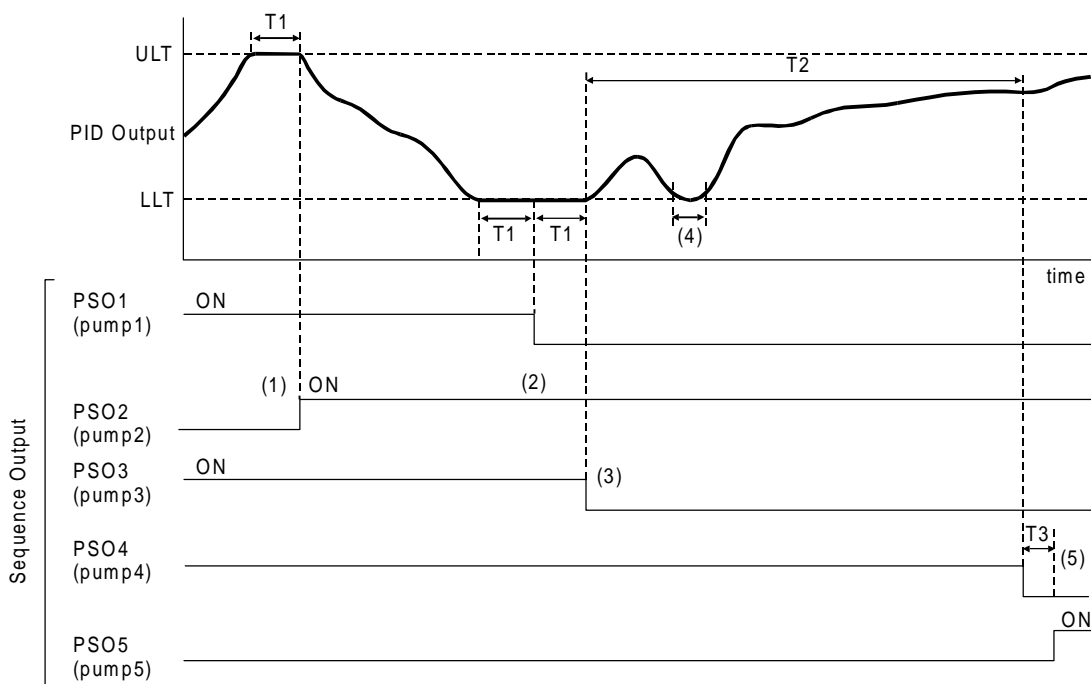

ULT: PID output upper limit value in VAT2000  
 LLT: PID output lower limit value in VAT2000  
 T1: Holding time  
 T2: Continuous operation time limit  
 T3: Changeover time

The ON/OFF control of multiple pumps is carried out so that the operation time of each pump is equal.

- (1) When the PID output reaches ULT for a time T1, the pump 2 with the shortest operation time turns ON (through PSO2 output).
- (2) When the PID output reaches LLT for a time T1, the pump 1 (PSO1), with the longest operation time turns OFF.
- (3) Following (2), when the PID output still hold at LLT for a time T1, the pump 3 (PSO3) with the longest operation time turns OFF.
- (4) ON/OFF pumps changeover is ignored If the PID reaches LLT or ULT for a shorter time than T1
- (5) If the time that the pump's ON/OFF control is carried out reaches T2, the pump 4 (PS04) with the longest operation time will turn OFF, and the pump 5 (PSO5) with the shortest operation time will turn ON after T3.

## 6. Control Functions and Parameter Settings

Other restrictions related to the pump's ON/OFF control are given below.

- (6) When the PID output reaches LLT, the pumps will sequentially turn OFF from the pump having the longest operation time. However if there are no pumps to turn OFF, the VAT2000 will stop. When the PID output rises and leaves LLT, the VAT2000 will resume operation

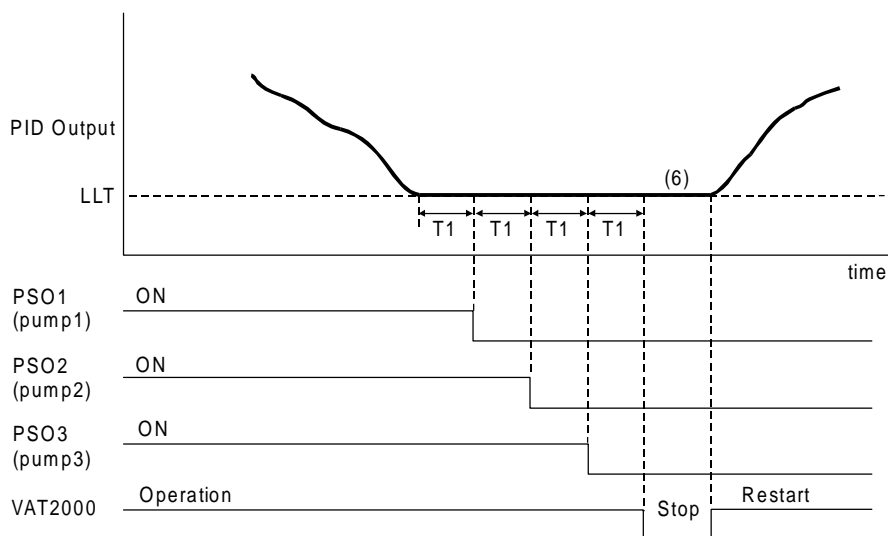

### VAT2000 automatic operation (three ON/OFF control pumps)

- (7) When the operating VAT2000's command (RUN) turns OFF, all commands for the pump function will simultaneously turn OFF.
- (8) If a fault occurs in the inverter, the following operation will take place.
- As long as the operating command RUN is held in ON state, the pump's control ON/OFF will be held. Equalisation of each pump's operation time will also be continued.
  - When the operating command RUN turns OFF, all commands for the pump will simultaneously turn OFF.
- (9) When the inverter's power is turned OFF, the operation time history for each pump will be lost.

## 2) Preparation for operation

- (1) Set the number of pumps to be ON/OFF controlled in parameter B44-0. One to five pumps can be set. The relation of the pump No. recognised in the inverter and the output terminals is as follows.

PUMP No.	Relay output terminals	
1	Standard	PSO1
2		PSO2
3		PSO3
4	Option	PSO4
5		PSO5

The pumps are started in the order of pump No. 1 to 5.  
The digital outputs not being used for ON/OFF control can be used as normal programmable outputs.

- (2) The multi-pump control, uses the PID function. Refer to the explanation given for the parameters B43-0 to 4. The PID is enabled setting PIDEN function to ON. The multi-pump control is always carried out in the remote mode (LCL OFF), through RUN, RRUN commands.
- (3) Refer to section (1) and set the parameters B44-1 to 3.
- (4) By using the setting interlock function (C20 = 0 to 3), the VAT2000 run/stop can be controlled by the pressure command input (FSV, FSI). In this case, the signal command (RUN-R.RUN) should be always ON. Refer to the explanation on C20-0 to 3

### B45-0~6

### Traverse run

Traverse function allows operation in which the frequency fluctuates with the pattern shown below. This is effective for evenly winding up the thread on a bobbin in a weaving system.

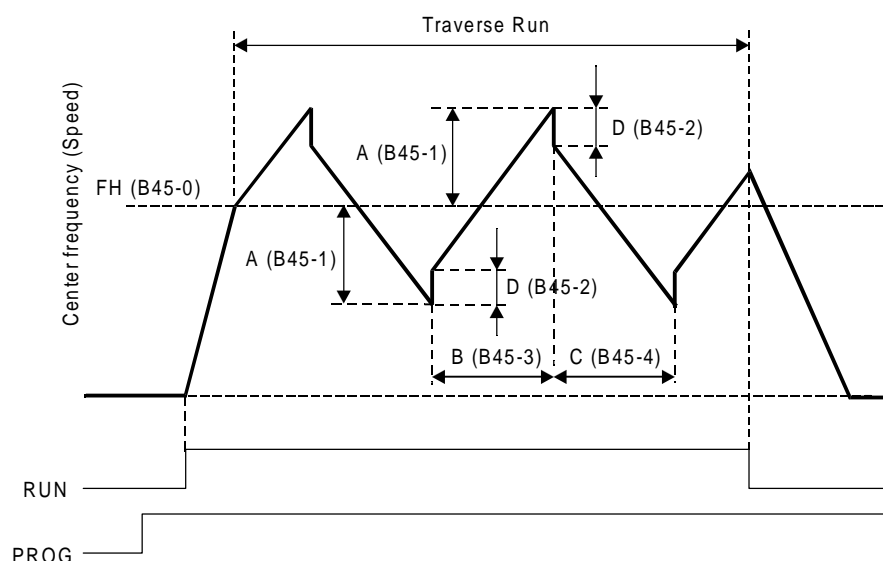

#### 1) Traverse run

- (1) To carry out traverse run, turn the sequence command PROG ON.
- (2) If the sequence command RUN or R RUN is turned ON, the machine will accelerate at the cushion (A01-0) at the center frequency (speed), and then traverse run will start.
- (3) When RUN (or R RUN) is turned OFF, the machine will decelerate to a stop with the cushion (A01-1).
- (4) During traverse operation, the conventional cushion, S-ramp, overcurrent limit (OCL) and overvoltage limit (OVL) will not function. However, these will function while accelerating or decelerating during start or stop.
- (5) The traverse center frequency (rotation speed) can be selected with C02-1.
  - C02-1 = 1: Analog fixed (C07-4)
  - = 2: Panel fixed (B45-0)
  - = 3: Sequence (S0,S1)

When using traverse run, set B11-8 to 1 (selection mode setting: binary mode).

If C02-1 is set to 1, the setting from an external source selected with C07-4 will be the center frequency (speed).

When C02-1 is set to 3, and traverse run is being carried out, the operations (2) and (3) described below will take place through the sequence command S0 and S1.

### 2) Deviated traverse X, Y operation

The deviated traverse operation shown below takes place with the sequence commands S0 (X) and S1 (Y) during traverse operation.

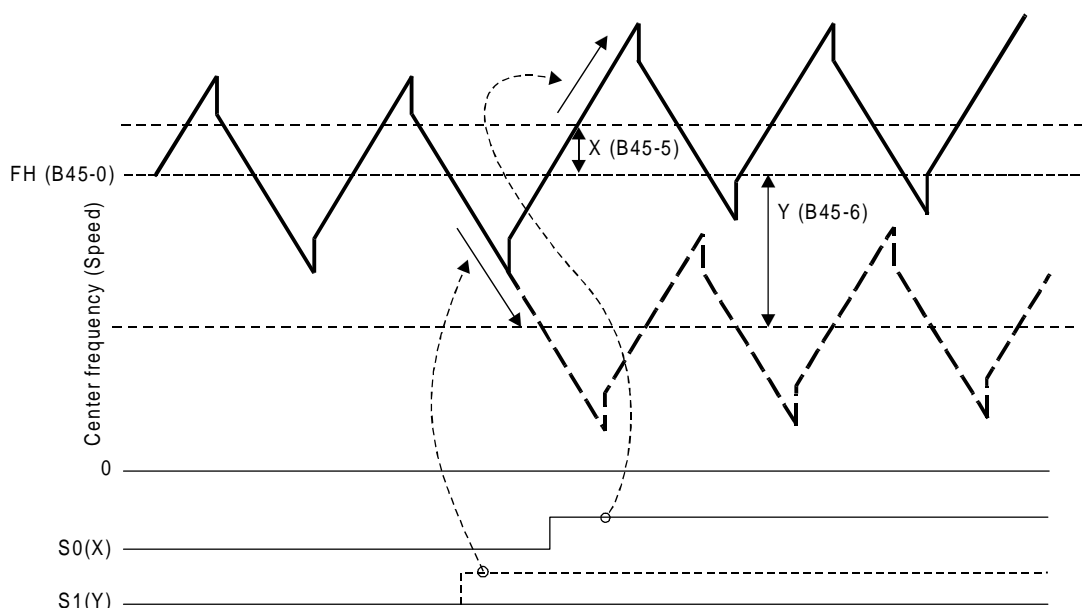

**Deviated traverse X, Y operation**

The center frequency (speed) rises by X (B45-5) only while S0 (X) is ON.  
The center frequency (speed) lowers by X (B45-6) only while S1 (Y) is ON.

### 3) Changing the center frequency (speed) with settings from an external source

While the PROG command is ON and the traverse operation is taking place, when the sequence commands S0 and S1 both turn ON, the center frequency value (speed) value will be the value set from an external source selected with C07-4.

If both S0 and S1 are turned ON, the center frequency (speed) will be the value set from the external terminal. However, the frequency will first return to the center frequency (speed) before rising or lowering to the newly set value. After that, the same operation will take place even when the setting value is changed from an external source.

### 4) Precautions for application

- (1) If the parameter No. B45-0 to 6 setting data is changed during traverse operation, the output frequency (speed) will return to the center frequency (speed) once. Then, traverse operation based on the newly set data will take place.  
When returning to the center frequency (speed), the output frequency (speed) will change at the cushion (A01-0, 1)
- (2) The overcurrent limit (OCL) and overvoltage limit (OVL) functions will not activate during traverse operation, so carefully consider the inverter capacity, motor capacity and traverse related setting values when designing the system.
- (3) The output frequency (speed) is limited between 5.00 and 100.00% during traverse operation.
- (4) When carrying out deviated traverse, take care not to turn the S0(X) and S1(Y) commands ON simultaneously.  
If turned ON simultaneously, the (3) center frequency (speed) will change.

**B50-0~0  
to B59-3**

**Pattern run function**

The frequency (speed), run direction and operation time can be controlled automatically with the pattern run function

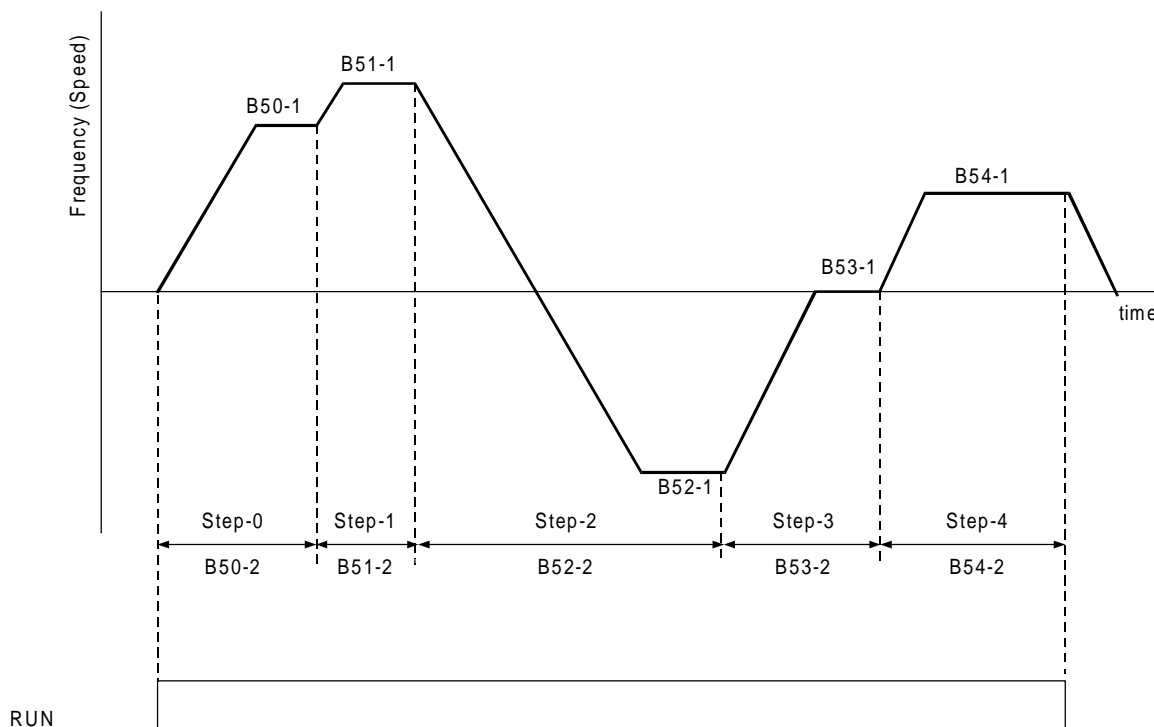

- (1) A max. of ten patterns can be set. Program in the B50-B59 blocks as shown below.  
The remote setting input point is selected with C02-0 = 4  
n is the step No. from 0 to 9.

B5n-0: Run mode

= 0: Stop

= 1: Forward run

= 2: Reverse run

= 3: Final step (set when repeating before B59)

B5n-1: Run frequency or speed (%)

B5n-2: Run time (sec)

B5n-3: Return destination step

= 0 to 8

(Set the No. of the step to be executed next when B5n-0=3.)

## 6. Control Functions and Parameter Settings

---

- (2) The sequence command functions will be as shown below during pattern running.

**RUN:** Pattern run starts when RUN turns ON. The operation starts from the run speed and operation time applied when the operation was previously stopped.

**Note 1)** The pattern running operates with the remote mode (LCL OFF).

**Note 2)** The R.RUN, F.JOG, and R.JOG commands are invalid during pattern running.

**S0:** Proceeds to the next step at the edge from OFF to ON. (Skip).

**S1:** The internal timer operation will hold when S1: ON. Use this to fold the function. By turning this signal ON/OFF with S0 ON (hold), the step can be proceeded in synchronisation with the peripheral machine regardless of the internal timer.

**S2:** If this signal is ON, the operation will be reset to step 0.

The S0 and S1 functions are valid only when RRUN is ON. The S2 function is not related to the ON/OFF setting of RUN, and is valid at all times.

When the drive is changed to local mode (LCL ON), the pattern run function is reset to step 0. During pattern run, set B11-8 to 1 (selection mode setting: binary mode).

- (3) When using pattern run, the sequence status output (D04-4) ACC and DCC functions will change as shown below.

**ACC:** Turns ON when the last step of the pattern run is being executed. (EOS)

**DCC:** Operates with the reverse logic of the above

**C00-0**

**Run command method**

C00-0 = 1; F.RUN, R.RUN

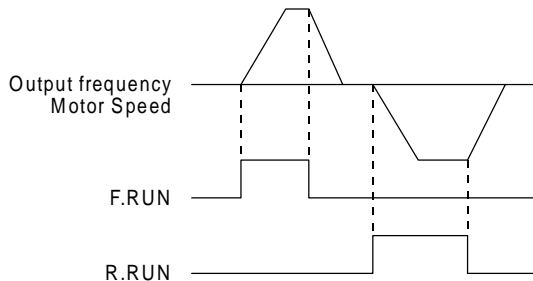
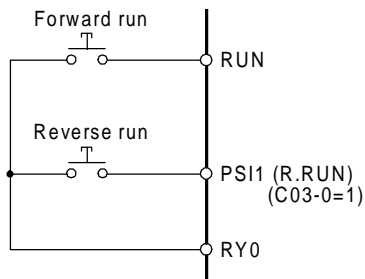

C00-0 = 2; RUN, REV

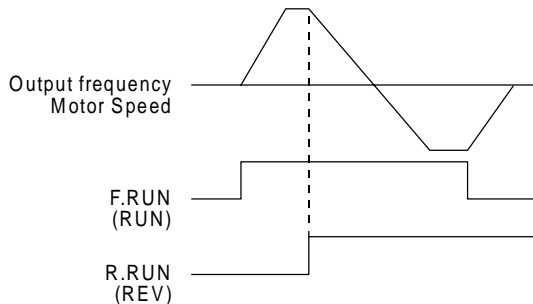
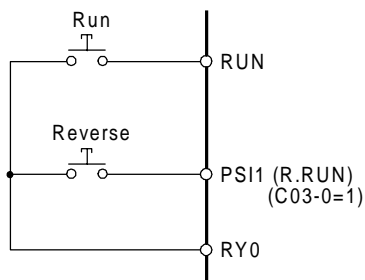

C00-0 = 3; Self hold

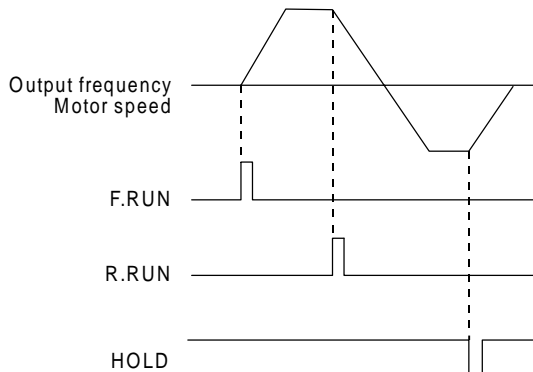
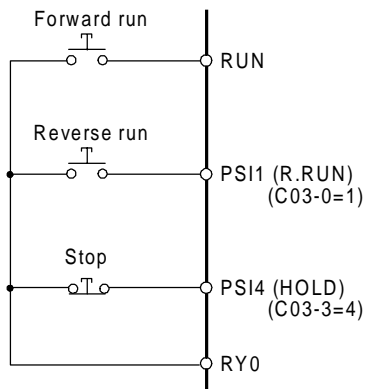

C00-1  
C00-2

### RUN/STOP methods

#### Jog stop method

- = 1: Coast to stop
- = 2: Deceleration to stop (Ramp down to stop)

Coast to stop refers to stopping by turning the VAT2000's output OFF at the stop command time. The motor will slow down by inertia

Deceleration stop refers to stopping the motor by decreasing the VAT2000's output according currently ramp down time adjusted. The VAT2000 injects a DC Voltage when the motor reaches minimum speed. (all parameters are adjustable).

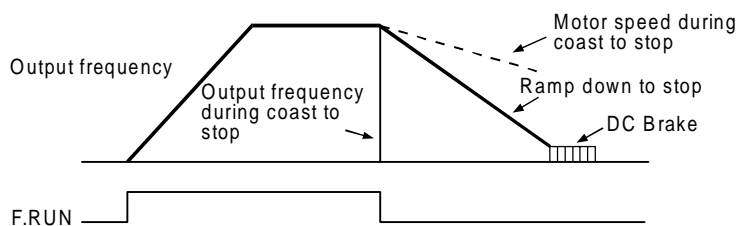

**(Note)** To restart after coast to stop, confirm that the motor has stopped. The inverter may trip if attempted when the motor is running. (For V/f control)

C00-3

### Emergency stop (EMS) input logic

- = 1: Close to stop (when a contact is connected)
- = 2: Open to stop (when b contact is connected)

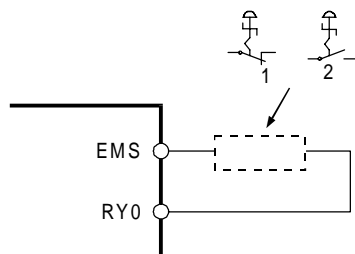

C00-4

### Emergency stop (EMS) mode

The emergency stop comand can be adjusted according the following actions,

- = 1: Coast to stop, without fault output
- = 2: Coast to stop, with fault output (When the EMS signal turns ON, the output will be shut off, and FLT will be ON.)
- = 3: Ramp down to stop (without fault output)

**C00-5**

### **Control source switchover method (J1 setting)**

J1 setting =1: OFF =2: ON

Select whether to use the terminal block input signals with the local operation mode.  
Refer to section 5-5 for details.

**C00-6**

### **Control source switchover method (J2 setting)**

J2 setting =1: OFF =2: ON

Select the auxiliary command input when the COP command is ON.  
Refer to section 5-5 for details.

**C02-0~8**

### **Various setting input selection**

Refer to section 5-9 for details.

**C03-0~7**

### **Sequence input terminal function – 1**

**C04-0~9**

### **Sequence input terminal function – 2**

**C05-0~9**

### **Sequence input terminal function – 3**

**C06-0~8**

### **Sequence input terminal function – 4**

Refer to section 5-3, 5-6 for details. Refer to the explanation for B06-0 to 6 (ratio interlock bias increase /decrease function) for details on C03-7 and C05-3 to 4.

**C07-0~9**

### **Analog input terminal function**

Refer to section 5-7 for details.

**C08-0**

**Automatic start.**

- = 1: OFF (The drive starts when run command is given after pre-charging. Run commands before that the power ON sequence is completed will be ignored)
- = 2: ON without pick-up  
If the run command is ON at the power ON time, then the drive will start once the pre-charging is completed.

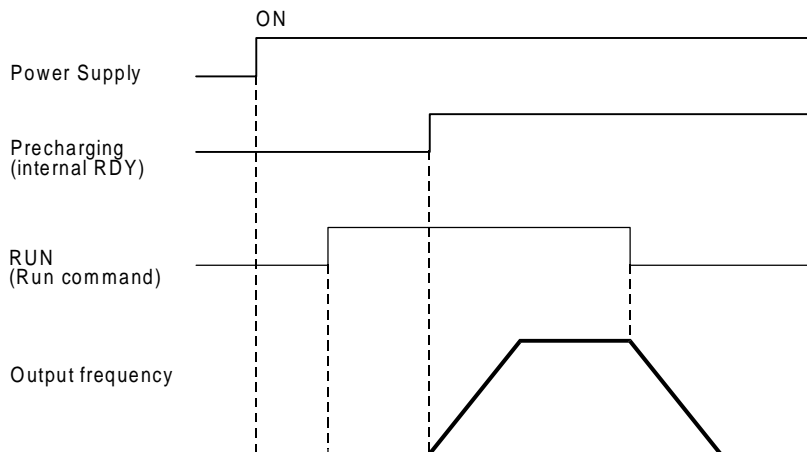

- = 3: ON with pick-up (flying start)  
If the run command is ON at the power ON time, then the drive will start once the pre-charging is completed, enabling the pick-up function. This mode is useful to start after a power interruption. When the drive is used as vector control with sensor, the pick up is not needed even if the motor is rotating when the drive re-starts. In this case set C08-0 to 2

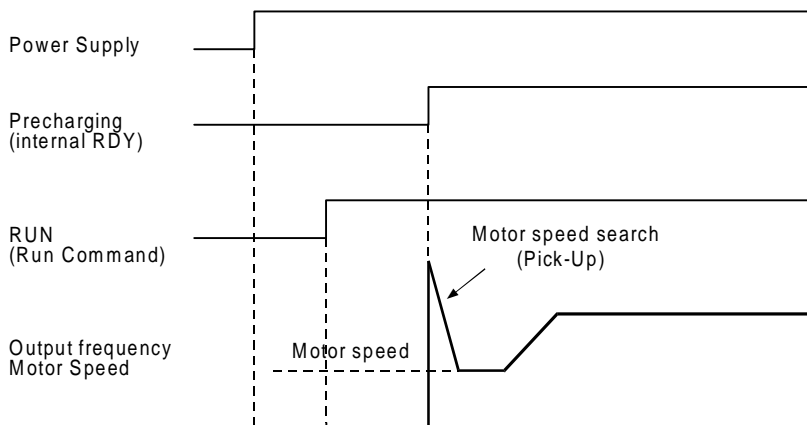

For V/f control, sensorless control C30-0=1,2,3

**(Note)** If auto start is used, undervoltage fault will not be detected. However, EC0~3 will output the undervoltage code.

**C09-0**

**Parameter protection**

Set this parameter to prevent unintentional operations from operation panel.  
Changing of the data can be protected per function group with the setting value as shown below.

○ : Unprotected  
(changeable)  
× : Protected  
(unchangeable)

value	Block A	Block B, C			
		Basic	Extn.	S/W	H/W
1	○	○	○	○	○
2	×	×	×	×	×
3	○	×	×	×	×
4	○	×	○	×	×
5	○	×	○	○	×
6	○	○	○	○	○
7 ~ 8	×	×	×	×	×
9	○	○	○	○	○

**(Note 1)** Set 2 to lock all changes.

**(Note 2)** Set 1 to allow all changes. The 9 setting is for maker maintenance, do not set it.

**C09-1**

**Operation panel lock**

[FWD] , [REV] , [STOP] key operations are protected.

= 1: All operation possible

= 2: All operation lock

Note, the motor will stop when the [STOP] key is pressed for two seconds

= 3: Only [STOP] key can be operated.

**C09-2**

**LCL switchover protection**

= 1: LCL mode switchover ([STOP] + [SET]) during running disabled

**(Note)** Even when stopped, if the terminal block's RUN, R.RUN, F.JOG or R JOG is ON, switchover to remote is not possible.

= 2: LCL mode switchover ([STOP] + [SET]) during running enabled

**C09-6**

**Fault history buffer clear**

The fault history details can be cleared by setting the value to 1 and then pressing [SET] key. This setting will not be registered in the internal memory. Thus, this parameter must be set each time.

Nothing will occur if set to a value other than 1.

Use this before handing the unit over to the final user.

**C09-7**

**Default value load**

All values per function group are changed to the default values.

- 9: All default values load (excluding maintenance)
- 10: Parameter A
- 11: Parameters B, C basic functions
- 12: Parameters B, C extended functions
- 13: Parameter B software option function  
Parameter C hardware option function
- 14: Parameters B basic functions
- 15: Parameters B extended functions
- 16: Parameter B software option function
- 17: Parameters C basic functions
- 18: Parameters C extended functions
- 19: Parameter C hardware option function

Nothing will occur when values other than the above are set.  
This parameter setting value will not be registered in the internal memory.

**(Note)** The setting values exceeding 2000 are codes for maker maintenance, so do not set. Otherwise, the internal factory adjustments may be lost and consequently the drive will become unadjusted.

**C10-0~7**

**Custom parameter register**

Set the No. of Block B, C parameter to be displayed on A04-0~7.  
To set block B parameter B10-1, set as 0.10.1.  
To set block C parameter C14-0, set as 1.14.0.  
Refer to section 4-7 for details.

- C12-0**
- C12-1**
- C12-2**
- C12-3**

**FSV terminal input mode**

**FS1 terminal input mode**

**AUX terminal input mode**

**Filter time constant for FSV/FSI and AUX input**

As an example, the analog input value through FSV, FSI and AUX (C07-0 = 2 to 4) and speed setting ratio is shown below. Refer to section 5-7-1 for additional details

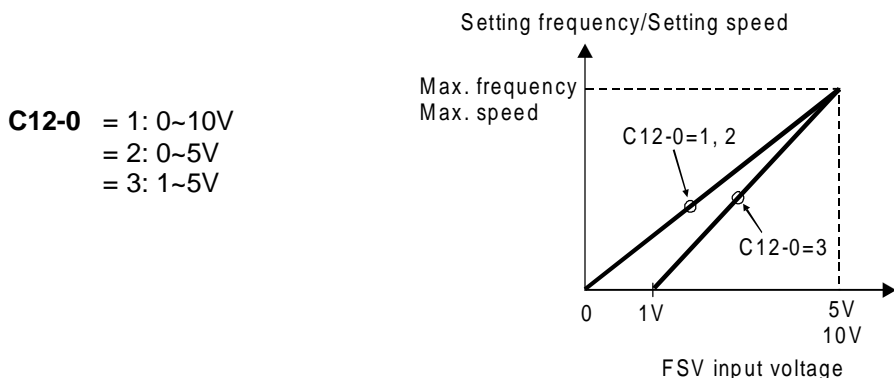

## 6. Control Functions and Parameter Settings

**C12-1** = 1: 4~20mA  
 = 2: 0~20mA

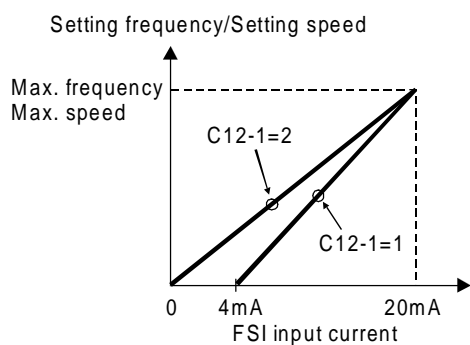

**C12-2** = 1: 0- ± 10V  
 = 2: 0- ± 5V  
 = 3: 1-5 V

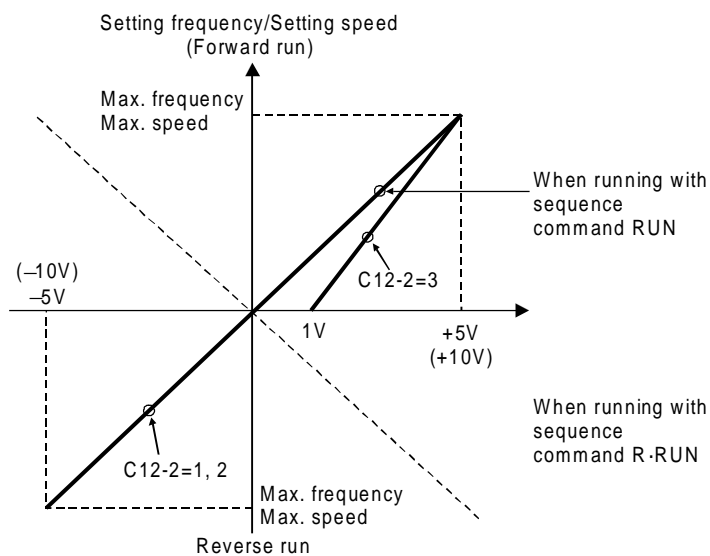

**C12-3** = 1: 8ms  
 = 2: 32ms

Fluctuation of the setting value caused by noise, etc., can be suppressed increasing the time constant by parameter C12-3

### C13-2~5

### PSO output terminal parameter

Refer to section 5-6-1 for details.

### C14-0

### Output gain for FM

### C14-1

### Output gain for AM

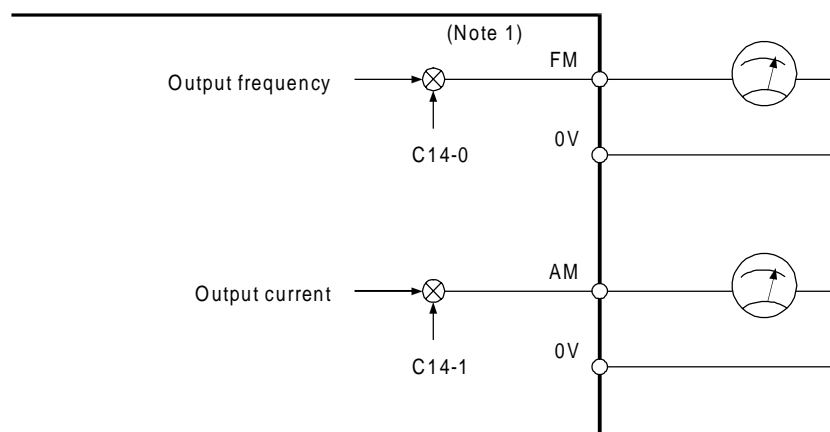

**(Note 1)** The maximum output voltage of the FM and AM outputs is approx. 11V.  
 If a large value is set in C14-0 and 1, a voltage exceeding 11V will not be output.

**C15-0**

**Attainment (ATN) detection width**

The attained output ATN operation width is set.

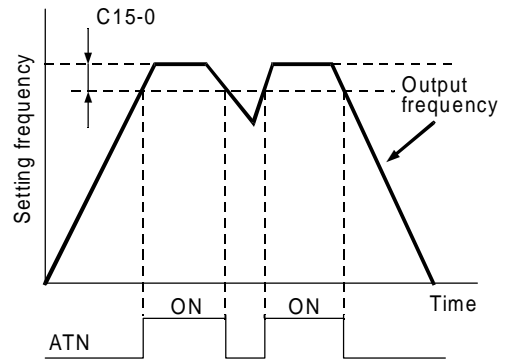

**C15-1**

**Current (IDET) detection level**

The current detection (IDET) operation level is set. Set with a percentage of the rated current (B00-6, B01-6). A 5% hysteresis is fixed for the IDET operation.

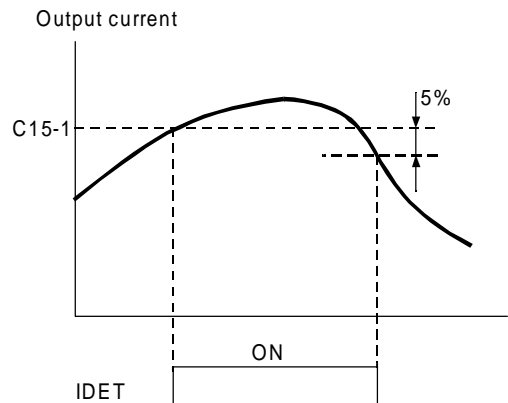

**C15-2**

**Speed detection (SPD 1) level – 1**

**C15-3**

**Speed detection (SPD 2) level – 2**

The speed detection SPD 1 and 2 operation level is set. Set with a percentage to the max. frequency (B00-4) or max. speed (B01-4). The output frequency or the motor speed will be the comparison target. A 1% hysteresis is fixed for SPD1 and SPD2 operation.

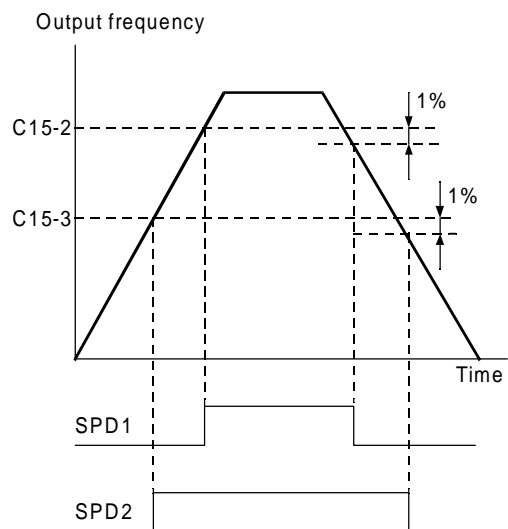

**C15-4**

**Zero speed detection (ZSP) level**

The zero speed detection ZSP operation level is set. Set with a percentage to the max. frequency (B00-4) or max. speed (B01-4). The output frequency or the motor speed will be the comparison target.

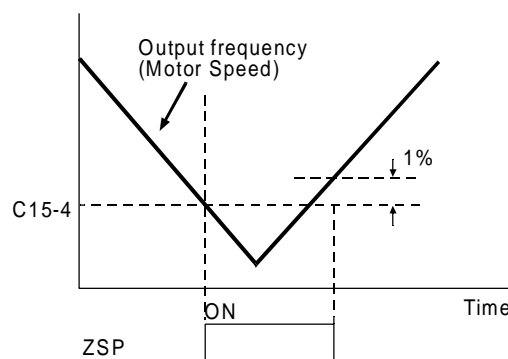

C20-0	Start/stop frequencies (speeds)
C20-1	Start/stop frequency (speed) hysteresis
C20-2	Interlock frequency (speed)
C20-3	Run delay timer

The following types of interlock can be obtained for the run RUN and R-RUN commands.

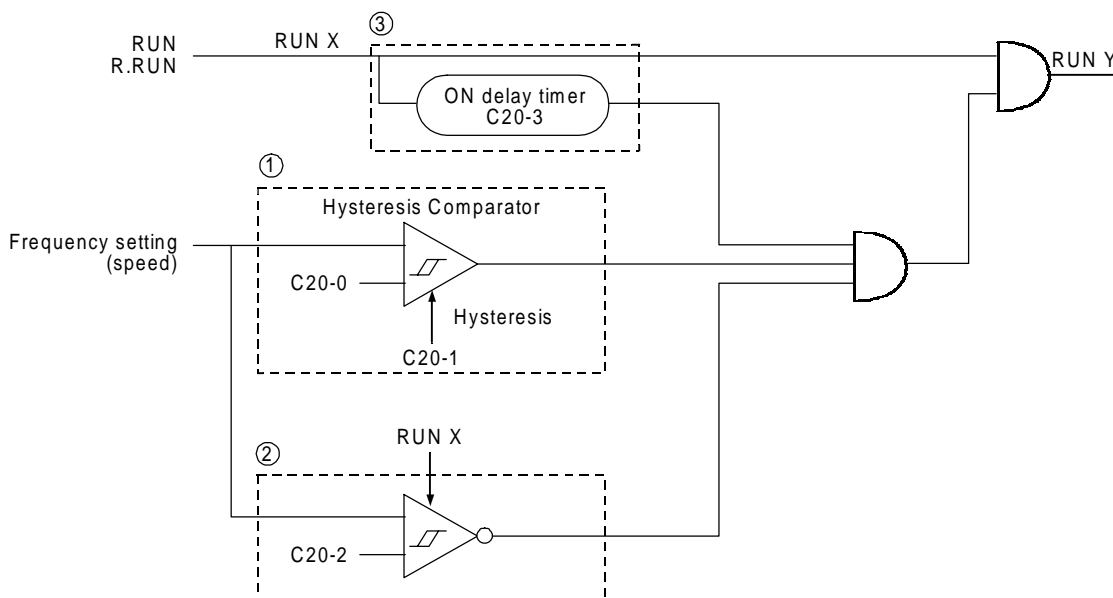

- (1) Setting start/stop function  
The motor will run when the frequency (speed) setting is higher than the C20-0 setting value, and will stop when lower.  
Starting and stopping with the setter is possible with this function.
- (2) Start interlock  
If the frequency (speed) setting value is larger than C20-2 when the run command (RUN X) is ON, the motor will not start.  
**(Note)** The setting start/stop and start interlock functions cannot be used simultaneously. Thus, set C20-0 or C20-2 to 0.

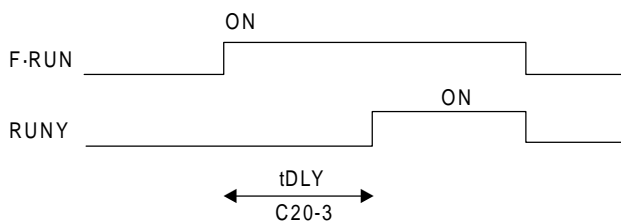

- (3) Run delay timer  
The motor will be delayed from the run command (RUN X) by the time set in C20-3.

This is used for synchronisation with peripheral machines such as mechanical brakes. The run delay timer will not function in the jogging or local modes.

- (Note 1)** Set the parameter setting values to 0 when not using (1), (2) or (3).
- (Note 2)** The (1), (2) and (3) functions will not function during jogging run.
- (Note 3)** The (3) function will not function during the local mode.
- (Note 4)** When interlock is applied on (1), (2) or (3), the FWD or REV LED will flicker.

C21-0
C21-1

**Number of retries**

**Retry wait time**

Retry is a function that performs its own fault reset and restarts with pick-up. Is possible to set the number of retries, and the wait time ( $t_{RW}$ ). An IO-4 fault will be output if the operation is not possible after the programmed re-tries.

The retry is effective against power module (P<sub>rn</sub> - n), overcurrent (OC - n), overvoltage (OV - n)<sup>Note 3</sup>, overload (OL - n), overheat (U<sub>OH</sub>), and ground fault (G-F) errors.

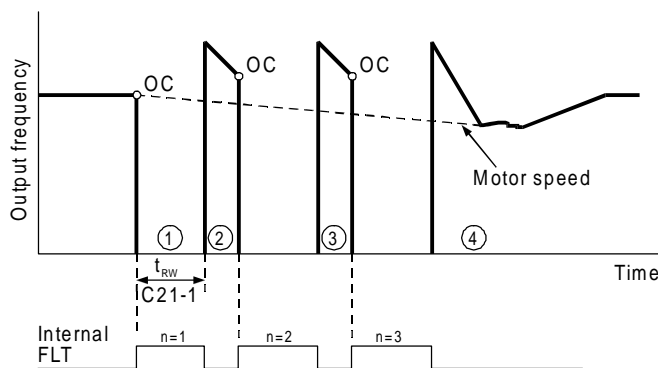

- ① Waiting time after trip by Overcurrent,  $t_{RW}$
- ② ③ Pick-up and retry
- ④ Pick-up achieved and retry finished

- (Note 1)** If C21-0=0, retry will not function.
- (Note 2)** The FA-FC relay output will stay open during retry, but will not function.
- (Note 3)** OVT retry may not function correctly if the DC voltage drop is slow.
- (Note 4)** If the run command turns OFF during retry, the retry will be cancelled, and the FA-FC relay contact will turn ON.
- (Note 5)** The pickup operation is not carried out during vector control with sensor (C30-0 = 4,5).

**CAUTION**

When a fault occurs on an extremely rare case, this function automatically resets the fault and restarts the operation.  
If the fault occurs frequently, the inverter could be damaged, so first remove the cause of the fault.

**C21-2**

**Pick-up wait time**

The wait time  $t_{PW}$  is a safety delay to ensure that the pick-up operation is enabled a time after the output is cut off, once the motor residual voltage is disappeared.  
 The residual voltage is a voltage generated by the motor after the inverter output turns OFF, and will be abated in approx. 1 to 3 seconds, but will take longer if the motor capacity is large.

**C21-3**

**Pick-up current limit value**

This is the current limit value exclusively used during pick-up. Normally, set 100%.  
 Adjust within the following range only when the output torque at restart must be limited.

$$\text{C21-3 Setting value} \geq \text{Applicable motor excitation current (\%)} + 10\%$$

(Normally 30 to 40%)

**<Pick-up operation>**

Pick-up starts when F.RUN or R.RUN is ON in the PICK ON state, or when the power is turned on while auto start with pick-up is enabled (C08-0=3).  
 The pick-up operation is carried out with the overcurrent limit function as shown below.

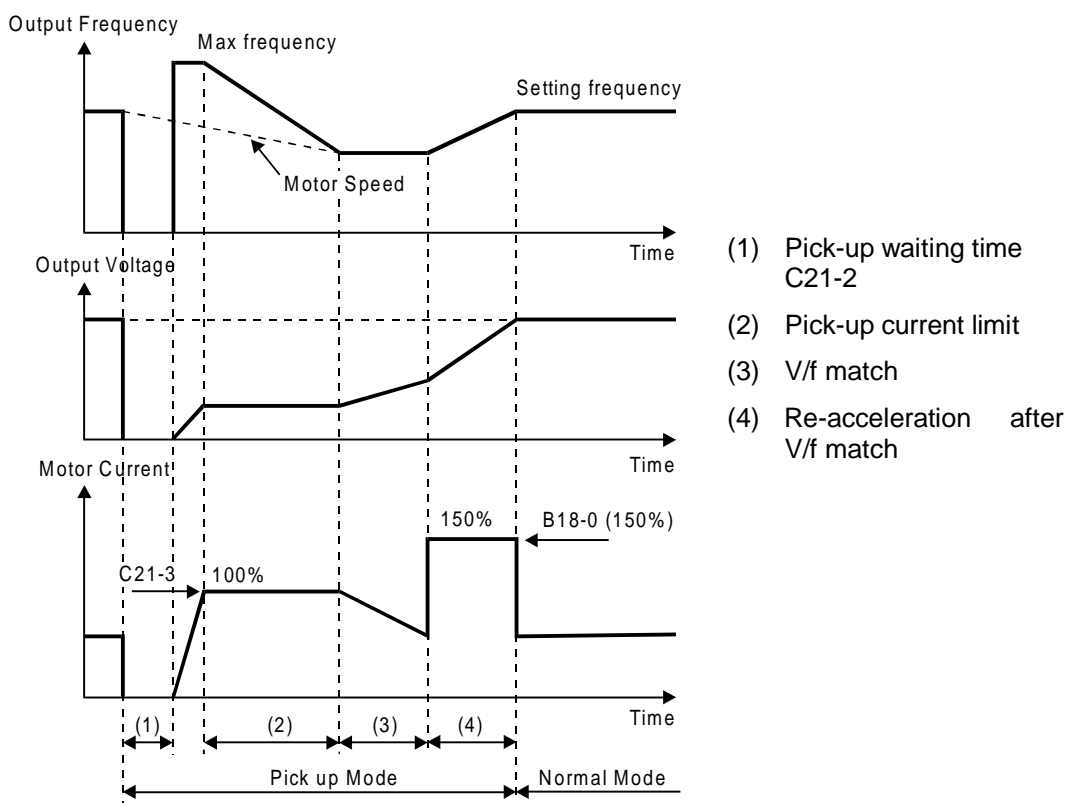

C22-0
C22-1
C22-2

**Overload setting (L0)**

**0Hz overload (L2)**

**0.7 Fbase freq. overload (L1)**

These are setting parameters for the overload (OLT) function.

The reverse time interval characteristics will change with the C22-0 setting as shown on the right.

The setting uses the motor rated current (B00-6, B01-6) as 100%.

**(Note 1)** Do not set a value that exceeds the inverter rated current.

When running a self-cooling type motor at a low speed, set C22-1 and C22-2 according to the motor characteristics. The characteristics will be as shown on the right.

**(Note 2)** At 1.0Hz or less, the inverter will trip at 75% of the inverter's rated current in one minute.

**(Note 3)** If the inverter output current exceeds 155%, the inverter will trip at 170% of the rated current in 2.5 seconds.

**(Note 4)** The above overload characteristics apply to V/f control (constant torque load) (C30-0 = 1), sensor-less vector control (C30-0 = 3), and vector control with sensor (C30-0 = 4).

Refer to section 6-7 for the overload characteristics when V/f control (variable torque load) is selected (C30-0 = 2).

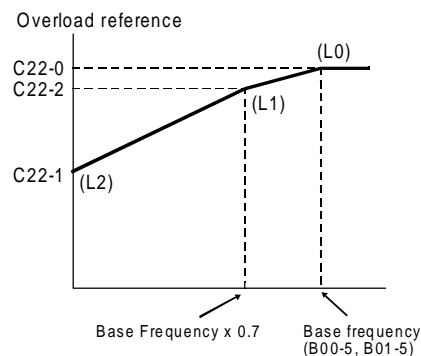
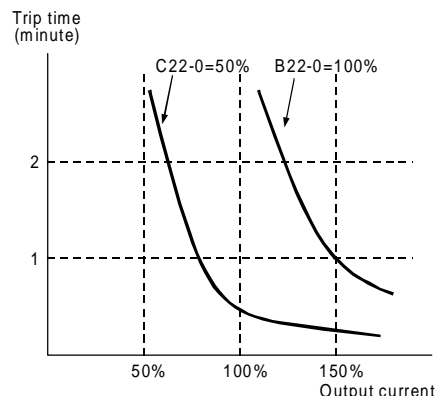

C22-4
-------

**Motor loss braking setting**

This parameter sets output voltage increase at the base frequency, in percentage respect to the rated output voltage (B00-3). Normally, this is set to 50% of the specified value.

When the DC voltage attempts to rise due to deceleration operation or a regenerative load, the motor loss braking function raises the inverter output voltage and decreases the motor efficiency to prevent tripping by an overvoltage. This function is valid only when the motor loss braking is selected with the DBR option selection (C31-0 = 3, 4) in the V/f control mode (C30-0 = 1, 2).

**(Note 1)** Take care to motor heating.

**(Note 2)** If the normal V/f setting is inappropriate, the motor efficiency will increase when the voltage is increased and thus tripping by overvoltage could occur easily.

**C24-0**

**Overspeed protection level**

This parameter set the overspeed protection level, as a percentage in respect to the maximum frequency (B00-4) or maximum speed (B01-4). The output frequency or motor speed is the target for comparison.

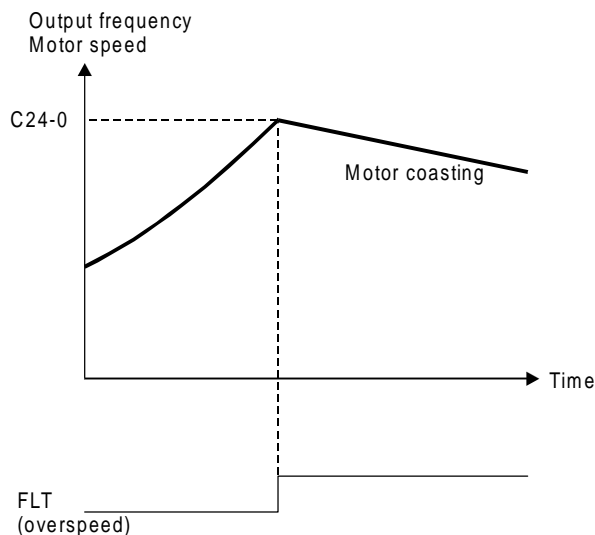

**C24-1**

**Control mode changeover during speed detection error**

This is valid when vector control with sensor (C30-0 = 4) is selected.

- = 1: The speed detection error is disabled.
- = 2: The speed detection function is enabled. Then if an error occurs, a fault (FLT) is output and the motor coasts to a stop.
- = 3: The speed detection error is enabled, and if an error occurs, a minor fault (ALM) is output. The control changes from the vector control with sensor to the sensor-less vector control, and the operation is continued. When the speed detection returns to the normal state, the control changes again from the sensor-less vector control to the vector control with sensor, and the minor fault output is cleared. The presence of a minor fault due to a speed detection error can be confirmed through the minor fault monitor (D05-0).

**C24-2**

**Speed detection error level**

**C24-3**

**Speed detection error recovery level**

This is valid when C24-1 = 3.

Set as a percentage in respect to the maximum speed (B01-4).

If the deflection of the speed detection value per 2ms increases above the value set with C24-2, it is judged as a speed detection error, and the control changes from the vector control with sensor to the sensor-less vector control. After changing, when the deflection of the speed estimated value for sensor-less vector control and the speed detection value drops to below the value set with C24-3, it will be judged that the speed detection has returned to the normal state. The control changes again from the sensor-less vector control to the vector control with sensor.

**C25-0**

**High-efficiency operation Voltage reduction time [sec]**

This setting value is the time to reduce the output voltage from the V/f setting value to 0V after the output frequency reaches the set frequency.

Normally, set the specified value (1.0). When using for loads with sudden torque fluctuations, and the output frequency drops remarkably with the overcurrent limit function, set a lower value. If the rotation becomes unstable during the voltage reduction or recovery operations, even causing a trip, set an higher value.

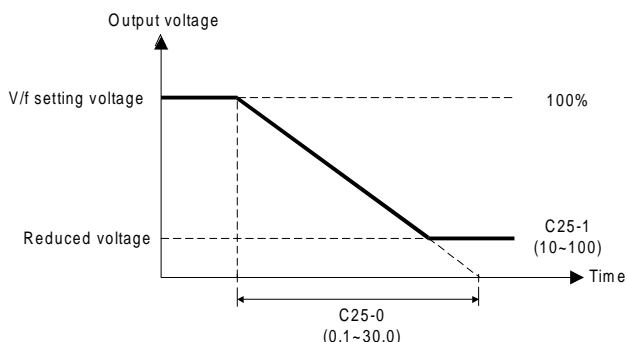

**C25-1**

**High-efficiency operation Voltage lower limit setting value [%]**

Set a value between 10 and 99 while the inverter is stopped to select the high-efficiency operation function.

When not using the high-efficiency operation function, set 100 while the inverter is stopped.

This setting value is the lower limit of the output voltage reduced when the high-efficiency operation function is selected, and uses the V/f setting voltage (output voltage when not using high-efficiency operation) as the reference.

Normally, the minimum value (10) is set. When using for loads with sudden torque fluctuations, and the output frequency drops remarkably with the overcurrent limit function, set an appropriately high value.

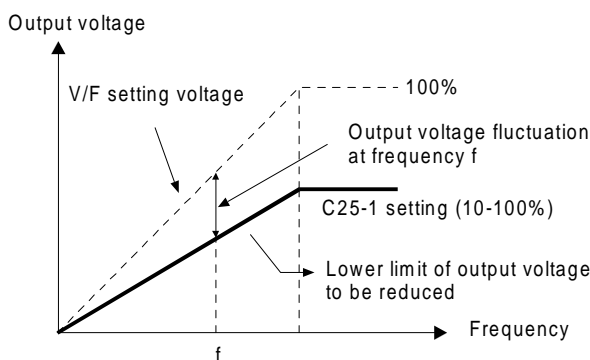

**high-efficiency operation principle**

Normally for the V/f constant operation, the no-load loss is large with a light load, and the motor efficiency drops remarkably. Thus, according to the load, the output voltage is reduced using the C25-1 setting value as the lower limit in respect to the voltage set with V/f, and the motor efficiency is improved.

**(Note)** Slipping will increase during high-efficiency operation, so it is recommended to execute automatic tuning before operation and set the automatic torque boost selection to valid (A02-1 =2).

**C31-0**

**DBR option selection**

Select the usage of the motor loss braking and DBR resistor (built-in or external). Refer to the explanation on the motor loss braking setting (C22-4) for details on the motor loss braking function.

The motor loss braking function is valid only when the V/f control mode (C30-0 = 1, 2) is selected.

**C50-1**

**Encoder output pulse No. selection**

The No. of encoder pulses (2-phase or 1-phase) is set.  
 The function to convert a 1-phase pulse signal from a proximity sensor, etc., into a 2-phase pulse is validated or invalidated.

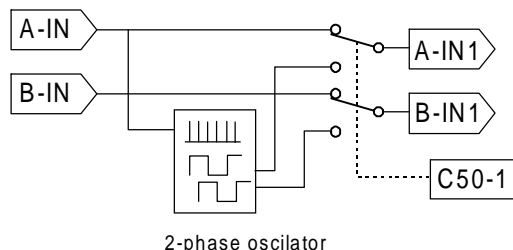

- =1: This is set when using an encoder that outputs a 2-phase pulse having a 90° phase difference. The rotation direction can be acknowledge, and the speed can be stable controlled even at low speeds.  
 Set the No. of pulses for one phase in the No. of encoder pulses (B01-8).
- =2: This is the set when using an encoder that outputs a 1-phase pulse.  
 Connect the input pulse to only the A phase, and always leave one phase disconnected.  
 With the 1-phase pulse mode, the rotation direction is recognised as the operating command direction. The forward run and reverse run directions are not known.  
 A speed detection error could occur due to the effect of chattering in low speed areas, so use the a 2-phase encoder when working at low-speed run or forward/reverse run.

(Note) The 1-phase pulse mode cannot be used with the PM control mode.

**C50-2**

**Encoder ABZ pulse type selection**

When using the 2-phase pulse, the rotation direction is judged by the advance and delay of the 2-phase pulse. With the VAT2000, the encoder pulse is defined as shown below during forward run. (The Z-phase pulse is the zero point position detection and is used only for PM motor control). When using an encoder with different signal specifications, use this setting to reverse the signal or convert the signal using the interchange function.

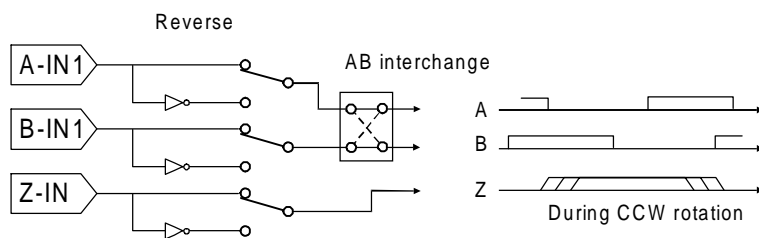

**Pulse conversion circuit**

**Definition of VAT2000 encoder**

## 6. Control Functions and Parameter Settings

---

The signal conversion circuit is according the following combination.

Setting No.	A-IN Direct/ Inverse	B-IN Direct/ Inverse	Z-IN Direct/ Inverse	AB inter-change
0	Direct	Direct	Direct	No inter-change
1	Inverse	Direct	Direct	
2	Direct	Inverse	Direct	
3	Inverse	Inverse	Direct	
4	Direct	Direct	Inverse	
5	Inverse	Direct	Inverse	
6	Direct	Inverse	Inverse	
7	Inverse	Inverse	Inverse	
8	Direct	Direct	Direct	AB inter-change
9	Inverse	Direct	Direct	
10	Direct	Inverse	Direct	
11	Inverse	Inverse	Direct	
12	Direct	Direct	Inverse	
13	Inverse	Direct	Inverse	
14	Direct	Inverse	Inverse	
15	Inverse	Inverse	Inverse	

**C51-0**

### Encoder UVW pulse type selection for Permanent Magnet motor (PM)

A position encoder which outputs a 3ph 180° square wave is used for permanent magnet motors. Check PCST3301 manual of optional U2KV23DN3 PM encoder card.

## 6-7 Application to square low variable torque load

### 6-7-1 Specifications for square low variable torque load

A load having characteristics in which the load torque varies with the speed, as a fan or pump, is called a square law variable torque load. The torque curves of the constant torque load and square torque load are shown below.

**CAUTION**

The variable torque specifications must be applied to square variable loads such as fans and pumps. The constant torque specifications must be applied for all other types of loads.

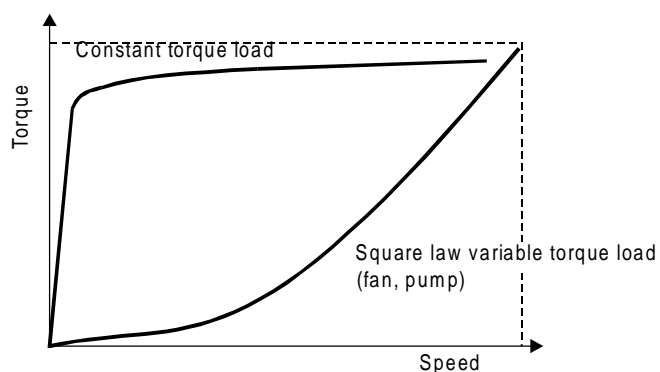

**Torque curve**

The specifications for both constant torque load and square law variable torque load are shown in Appendix 1. Hereafter, the square law variable torque load characteristics will be called the variable torque.

## 6. Control Functions and Parameter Settings

### 6-7-2 Selection of load characteristics

Select the load characteristics by setting the following parameters.

Table

No.	Name	Default value	Min. value	Max. value	Unit	Function
C30 - Control mode selection						
0	Control mode selection	1.	1.	5.	—	= 1 : V/f control (constant torque: overload characteristics 150% for one minute.) = 2 : V/f control (variable torque: overload characteristics 120% for one minute.)

- (1) The default setting is for constant torque load characteristics, so change the setting according to the application. When this parameter is set, some others like limits or current ratings shift to specific default values given for CT or VT control mode, so this parameter must be set prior than any other parameter.
- (2) This parameter is not affected by C09-7: default value load.
- (3) The parameters with setting values and setting ranges that shift when this parameter is selected are shown below.

Table \_

No.	Name	Default value	Min. value	Max. value	Unit	Function
A02 - Torque boost						
2	Manual torque boost setting	(Note 1)	0.0	20.0	%	Setting of torque boost at 0Hz.
A03 - DC brake						
2	DC braking voltage	(Note 1)	0.1	20.0	%	
B00 - Output rating						
6	Constant torque	(Note 2) Inverter rating	Constant torque rated current × 0.3~1.0		A	Overcurrent limit OLT, current % display, meter output reference value
	Variable torque		Variable torque rated current × 0.3~1.0			
B18 - Overcurrent limit						
0	Constant torque	150.	50.	300.	%	
	Variable torque	105.	50.	120		

**(Note 1)** The default value differs according to the inverter capacity and load characteristics selection.

**(Note 2)** For the inverter rating value, the constant torque rated current value and variable torque rated current values given in Appendix 1 will apply.

## 6. Control Functions and Parameter Settings

Table

No.	Name	Default value	Min. value	Max. value	Unit	Function
C22 - Overload						
0	Overload setting					
	Constant torque	100.	50.	105.	%	The C22-1, 2 data will be limited by this value when this value is changed.
Variable torque	100.	50.	100.			
1	0Hz overload				%	The max. value is the value of C22-2.
	Constant torque	100.	20.	105.		
Variable torque	100.	20.	100.			
2	0.7 Base freq. overload				%	The max. value is the value of C22-1.
	Constant torque	100.	50.	105.		
Variable torque	100.	50.	100.			

**(Note 3)** When the load characteristics are changed, the above parameters will be forcibly set to the default values, so reset them when necessary.

**(Note 4)** For parameters other than above, the default value and setting range will not change when the load characteristics are selected.

### 6-7-3 Overload Characteristics

The overload detection curve changes according to the load characteristics selection.

The overload characteristics for when the overload setting (C22-0) is 100% are shown below.

The motor rated current (B00-6) is the reference for the current value (%).

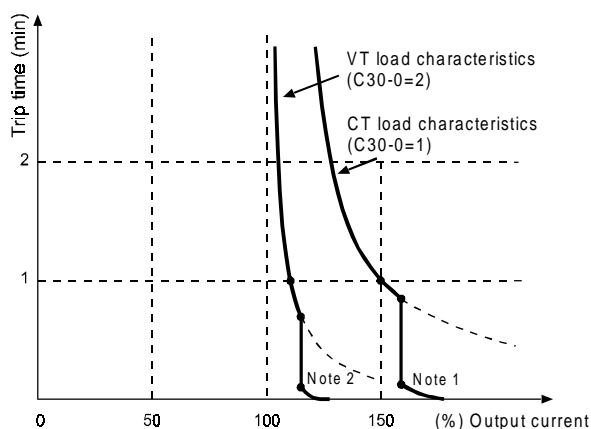

**Overload characteristics**

**(Note 1)** When the constant torque lead characteristics are selected, the trip will occur at the following:

- (1) When 1.0Hz or less, at the reverse time interval characteristics of 75%, 60s of the constant torque rated current.
- (2) When 155% of the constant torque rated current is exceeded, at the reverse time interval characteristics of 160%, 10S and 170%, 2.5S.

**(Note 2)** When the variable torque load characteristics are selected, the trip will occur at the following:

- (1) When 1.0Hz or less, at the reverse time interval characteristics of 75%, 24s of the variable torque rated current.
- (2) When 120% of the variable torque rated current is exceeded, at the reverse time interval characteristics of 125%, 7.5S and 135%, 0.94S.

### 6-8 Adjusting the vector control speed control related parameters

With the VAT2000, ASR operation is possible by executing automatic tuning and setting simple speed control parameters. However, when carrying out high-response or high-accuracy control, the parameters must be adjusted in detail. In this section, the configuration and adjustment parameters of the speed control system is explained.

#### 6-8-1 Speed control system for Induction Motors

The speed control system of VAT2000 is configured of blocks as shown below. Automatic tuning is used for adjusting the exciting current control, current regulator, flux observer and speed estimation mechanism, so these parameters often do not need to be adjusted. However, the parameters related to the speed regulator, torque limit, load torque observer, various low path filters, etc., must be adjusted according to the user's system. Thus, these cannot be simply adjusted with automatic tuning. The final user of the system must adjust these parameters to match the system. Adjustments are carried out while referring to the block diagram below.

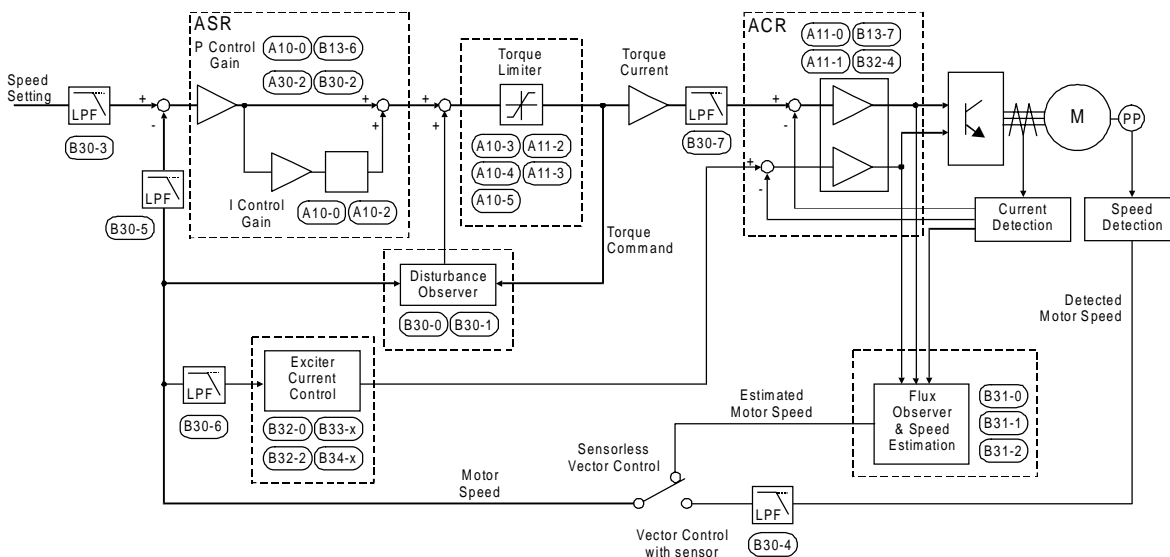

VAT2000 speed control system block diagram

(Note) The related parameter Nos. are indicated in the above function blocks.

### 6-8-2 Speed regulator (IM)

The speed regulator (ASR) is configured of PI control, and has the following parameters.

Parameter No.	Parameter	Function
A10-0	ASR response	Set the required ASR response in radians
A10-1	Machine time constant1	Set the time to accelerate the motor and load to the base speed at the rated motor torque.
A10-2	Integral time constant compensation coefficient	Set the compensation coefficient applied on the integral time constant of the speed regulator (ASR).
B13-6	ASR gain compensation in constant power range	This sets the ASR P gain compensation value at the max. speed. By adjusting this parameter, the ASR P can be compensated in the constant power range. If ASR hunting occurs in the sensor-less control's constant output range, set a smaller value.
B30-2	ASR proportional change rate limit	This limit the ASR's Proportional block, if the speed setting value or motor speed change suddenly,.

### 6-8-3 Motor Torque limit (IM)

The output torque is limited. Set an appropriate value for protecting the load side.

Drive torque limit)                      Set this to a large value to increase the torque during driving. Note that the output torque is limited by the output current limit (B18-0), so when set excessively, the set torque may not be attained.

Regenerative torque limit)              Set this to a large value to increase the torque during regeneration. Note that the output torque is limited by the output current limit (B18-0), so when set excessively, the set torque may not be attained. If the DBR or PWM converter, etc., are not provided and an excessively large setting is made, an overvoltage trip could occur during regeneration. In this case, lower the regeneration torque limit setting.

Parameter No.	Parameter	Function
A10-3	ASR drive torque limit	Drive torque limit in ASR control.
A10-4	ASR regenerative torque limit	Regenerative torque limit in ASR control.
A10-5	Emergency stop regenerative torque limit	Regenerative torque limit value for emergency stop in ASR Control.
A11-2	ACR drive torque limit	Drive torque limit in ACR control.
A11-3	ACR regenerative torque limit	Regenerative torque limit in ACR control.

6-8-4 Exciting current control

The exciting current is controlled to establish the secondary flux. A current reduction process in the constant output range or during voltage saturation, and high-speed magnetising control to raise the secondary flux at a high speed are also carried out.

Parameter No.	Parameter	Function
B32-0	Speed flux control selection	This is the control selection for magnetising the secondary flux to a high speed when starting operation. Select this to increase the motor speed even slightly when starting operation.
B32-2	Voltage saturation compensation selection	If the output voltage in control is larger than the voltage that can be output by the inverter, select this control to limit the exciting current to prevent the current or torque from hunting. Select this when raising the output voltage to near the input voltage, or when the input voltage changes. Note that if voltage saturation occurs, some torque ripple will occur. In this case, lower the B01-9 no-load voltage setting to avoid voltage saturation.
B33-x	Table reference speed	This is the reference speed for changing the compensation amount according to the operation speed. Set as shown below to operate to the constant output range.
B34-x	M fluctuation compensation	This compensates the exciting inductance fluctuation according to the B33 table reference speed. Set the compensation table so that the output voltage is constant during no-load operation through the entire operation range. * This is adjusted by the automatic tuning mode 4. (B19-0)

<Setting the table reference speed>

M' fluctuations greatly immediately after entering the constant output range, so set using the following diagram as a reference. (The base speed is 1.)

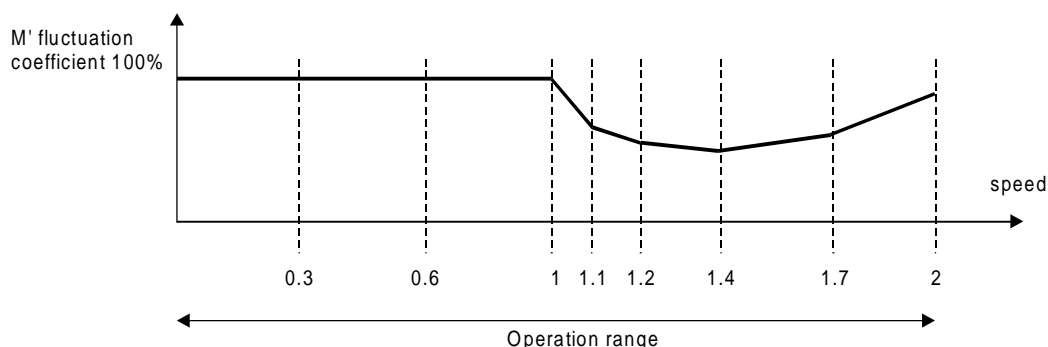

Setting the reference speed table

**6-8-5 Current regulator (IM)**

The current regulator (ACR) is a PI type control, including the following parameters.

<b>Parameter No.</b>	<b>Parameter</b>	<b>Function</b>
A11-0	ACR response	Set the ACR response in radians. If the response is too low or too high, the current will become unstable, and the over current protection will function.
A11-1	ACR time constant	The ACR time constant is set. If the time constant is too long or too short, the current will become unstable, and the over current protection will function.
B13-7	ACR gain compensation in constant power range	This sets the ACR Proportional gain compensation value at the max. speed. (above base speed)
B32-4	ACR voltage model FF selection	The voltage fluctuation caused by the leakage inductance is feed forward controlled. The current regulator (ACR) response speed will be increased. Select this if the current hunts in the high-speed operation range during sensor-less control.

**6-8-6 Flux observer and speed estimation mechanism (IM)**

These are parameters used with speed sensor-less vector control.

<b>Parameter No.</b>	<b>Parameter</b>	<b>Function</b>
B31-0	Flux observer gain	This is the feedback gain for the flux observer. If hunting occurs at the estimated speed in the high-speed operation range, adjust within the range of 1.2 to 0.9.
B31-1	Speed estimated proportional gain	This is the proportional gain for the adaptive speed estimation mechanism. To increase the speed estimation response, set a large value. Note that if the value is too high, the speed estimation value will hunt.
B31-2	Speed estimated integral gain	This is the integral gain for the adaptive speed estimation mechanism. To increase the speed estimation response, set a large value. Note that if the value is too high, the speed estimation value will hunt.

### 6-8-7 Load torque observer (IM)

The disturbance load applied on the motor is calculated and the torque command is compensated. To increase the response toward disturbance, use the load torque observer. By setting the speed regulator (ASR) to P and using the load torque observer, overshooting can be suppressed.

Parameter No.	Parameter	Function
B30-0	Load torque observer gain	Set the observer gain for the load torque observer. To increase the responsiveness of the external disturbance response characteristics, set a large gain. Note that if the gain is set too high, the output torque could hunt. When set to zero, the load torque observer will not function.
B30-1	Model machine time constant	Set the model machine time constant used by the load torque observer.

### 6-8-8 Various low path filters (IM)

The time constants of the low path filters used for speed detection, speed commands or torque current commands, etc., are set. By adjusting these time constants, vibration caused by noise and overshooting can be suppressed. Note that if an excessively high value is set, the control performance could drop.

Parameter No.	Parameter	Function
B30-3	Speed setting LPF time constant	Overshooting can be suppressed by setting this to the filter time constant equivalent to the speed response.
B30-4	Speed detection LPF time constant	The speed detection noise is cut.
B30-5	Speed detection LPF time constant for ASR	Set the low path filter time constant used for the speed detection value input into the speed regulator.
B30-6	Speed detection LPF time constant for compensation	Set the low path filter time constant used for the speed detection value for constant output range compensation or iron loss compensation, etc.
B30-7	Torque current command setting LPF time constant	Set the low path filter time constant used for the torque current command.

## Chapter 7 Options

### 7-1 Outline of options

The VAT2000 Series include the options shown below. This chapter will focus on the stand-alone options and main circuit wiring devices.

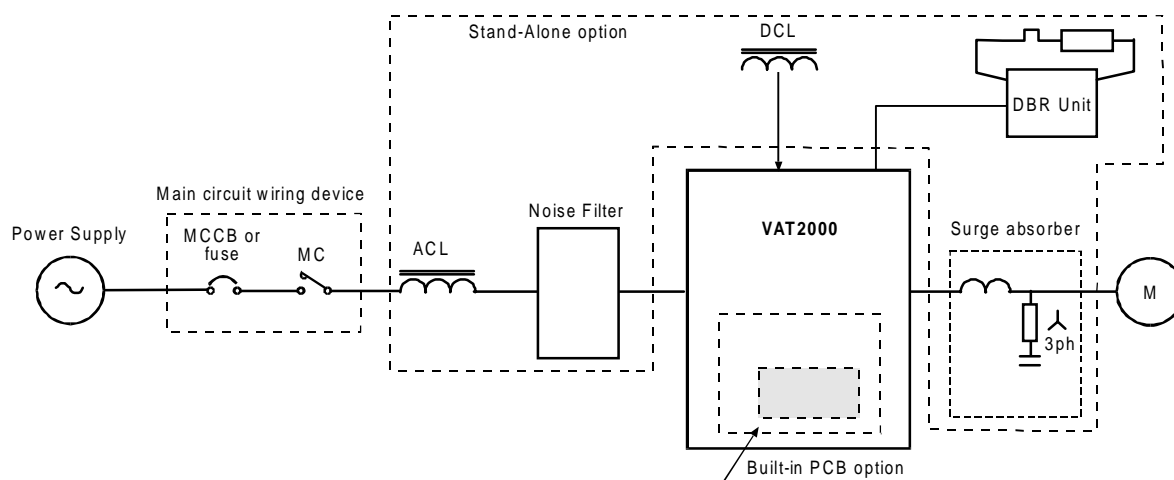

Fig. 7-1 Option configurations

Table 7-1

Item	Type	Function
<b>Main circuit wiring devices</b>		
Breaker for wiring (MCCB) or Fuse	Select a device that matches the inverter rating. (Table 7-2.)	Always install this device to protect the wiring of the inverter and peripheral devices.
Magnetic contactor (MC)	Select a device that matches the inverter rating. (Table 7-2.)	Install this device to provide an operation interlock. When using the DBR unit, always install this device to protect the DBR. (Refer to Fig. 2-4.)
<b>Stand-alone options</b>		
ACL	ACRxxxx (Refer to Table 7-2.)	If the capacity of the inverter's power supply transformer exceeds 10 times the inverter unit capacity, always install this device to protect the inverter. (Balance with power supply) This is also effective in improving the power factor of the inverter input and in suppressing the current high harmonics. The power factor will be approx. 0.9.
DCL	DCRxxxx (Refer to Table 7-2.)	Install this device to improve the power factor of the inverter input. This is also effective in creating a balance with the power supply as the ACL. The power factor will be approx. 0.9.
Noise filter (EMC Filter)	V2KFxxxx PRxxxx (Refer to Table 7-2.)	This device suppresses the electromagnetic noise generated by the inverter. This is required to comply with EMC. The electromagnetic noise is the radiation of electromagnetic waves in the radio frequency bands and that conveyed to the power supply wires.
DBR unit	U2KV23DBUxx (Refer to Table 7-2.)	This is used when the motor is to be stopped with dynamic braking for units larger than U2KX07K5S or U2KN07K5S
Surge Absorber	ACRxxx plus RC filter	This suppress surge voltage at motor side, which may be generated, if length of output motor cable exceeds of 30mts

## 7. Options

**Table 7-1 (continued)**

<b>Plug-in PCB options</b>			
<b>Item</b>	<b>Type &amp; Manual</b>	<b>Function</b>	<b>Option class</b>
Speed detection 1 (complimentary compatible)	U2KV23DN1 (PCST-3299)	This is a speed detection PCB for the IM vector control with speed sensor, and is compatible with the complimentary output type encoder. Response frequency: Change between 60±10kHz and 20kHz.	I
Speed detection 2 (line driver compatible)	U2KV23DN2 (PCST-3300)	This is a speed detection PCB for the IM vector control with speed sensor, and is compatible with the line driver output type encoder. Response frequency: 250kHz (signal: A, B, Z phase)	I
Speed detection 3 (PM compatible)	U2KV23DN3 (PCST-3301)	This is a speed detection PCB for the PM drive control, and is compatible with the line driver output type encoder. Response frequency: 250kHz (signal: A, B, Z, U, V, W phase)	I
Relay interface	U2KV23RY0 (PCST-3302)	This is used to expand the contact input/output points. Relay input : 4 points (PSI6 to 9) 1c contact output : 2 points (PSO4, 5)	III
PC interface	U2KV23PI0 (PCST-3303)	This is used to receive parallel settings from the PLC. Parallel data input : 16 bits Data length : 16, 12, 8 bits selective Format : Binary or BCD selective Open collector output: 2 points (PSO4, 5)	III
Serial interface	U2KV23SL0 (PCST-3304)	This is used to make a connection with serial transmission to the personal computer, etc. Transmission : RS-232C, RS-422/485Multi-drop is possible for up to 32 units. Baud rate : 1200~9600 bps	III
Profibus interface	U2KV23SL6 (PCST-3307)	This is used to make a connection with the network on the Profibus DP communication protocol. Baud rate : 12Mbps No. of stations : 126 stations	III

The above Optional PCBs must be installed by the user. Please ask your supplier for dedicated instruction manuals.

## 7. Options

**Table 7-2 Main circuit wiring device ratings and stand-alone option types (1) (4)**

### CONSTANT TORQUE RATINGS

VAT2000 CT Ratings	Fuse (2) (A)	MCC (3) (A)	Line MC	EMC Filter	Dynamic Braking Module	Braking Resistors (Note 5)	INPUT AC Reactor	DC Reactor	Surge Absorber (6)
									Out. Reactor
U2KN00K4S	20	5	CL00	U2KF3016MD1	Built in	TLR405P200	ACR4A2H5	-	-
U2KN00K7S	20	5	CL00	U2KF3016MD1	Built in	TLR216P200	ACR6A2H5	-	-
U2KN01K5S	50	10	CL00	U2KF3016MD1	Built in	TLR108P200	ACR9A1H3	-	-
U2KN02K2S	60	15	CL00	U2KF3030MD1	Built in	TLR74P200	ACR12A0H84	-	-
U2KN04K0S	110	20	CL01	U2KF3030MD1	Built in	TLR44P600	ACR18A0H56	-	-
U2KN05K5S	125	30	CL02	U2KF3060MD2	Built in	TLR29P600	ACR27A0H37	DCR32A0H78	-
U2KN07K5S	225	40	CL04	U2KF3060MD2	Built in	TLR22P600	ACR35A0H27	DCR45A0H55	-
U2KN11K0S	225	75	CL04	U2KF3094MD3	U2KV23DBUL1	TLR15P1000	ACR55A0H18	DCR60A0H4	-
U2KN15K0S	250	75	CL06	U2KF3094MD3	U2KV23DBUL1	TLR11P1200	ACR70A0H14	DCR80A0H3	-
U2KN18K5S	400	100	CL07	PR3120STD	U2KV23DBUL1	TLR8,8P1500	ACR80A0H14	DCR100A0H24	-
U2KN22K0S	500	150	CL09	PR3120STD	U2KV23DBUL2	TLR7,4P1800	ACR97A0H11	DCR120A0H2	-
U2KN30K0S	500	150	CL10	PR3150STD	U2KV23DBUL2	TLR5P2500	ACR140A0H072	DCR150A0H17	-
U2KN37K0S	600	200	CK75	PR3180STD	U2KV23DBUL3	TLR4P3000	ACR180A0H056	DCR180A0H14	-
U2KX00K4S	10	5	CL00	U2KF3016MD1	Built in	TLR864P200	ACR3A8H1	-	ACR3A0H05
U2KX00K7S	10	5	CL00	U2KF3016MD1	Built in	TLR864P200	ACR3A8H1	-	ACR3A0H05
U2KX01K5S	20	5	CL00	U2KF3016MD1	Built in	TLR432P200	ACR4A5H1	-	ACR4A0H05
U2KX02K2S	30	5	CL00	U2KF3016MD1	Built in	TLR295P200	ACR6A3H4	-	ACR6A0H05
U2KX04K0S	50	15	CL00	U2KF3016MD1	Built in	TLR175P600	ACR10A2H	-	ACR10A0H05
U2KX05K5S	60	20	CL00	U2KF3032MD2	Built in	TLR118P600	ACR14A1H4	DCR18A2H9	ACR14A0H05
U2KX07K5S	90	30	CL02	U2KF3032MD2	Built in	TLR86P600	ACR18A1H1	DCR25A2H1	ACR18A0H05
U2KX11K0S	110	40	CL04	U2KF3058MD3	U2KV23DBUH1	TLR59P1000	ACR27A0H75	DCR32A1H6	ACR27A0H05
U2KX15K0S	125	40	CL04	U2KF3058MD3	U2KV23DBUH1	TLR43P1000	ACR35A0H58	DCR40A1H2	ACR35A0H05
U2KX18K5S	175	50	CL04	U2KF3058MD3	U2KV23DBUH1	TLR35P1500	ACR38A0H58	DCR50A0H96	ACR38A0H05
U2KX22K0S	225	50	CL06	U2KF3096MD4	U2KV23DBUH2	TLR29P1800	ACR45A0H45	DCR60A0H82	ACR45A0H05
U2KX30K0S	250	75	CL06	U2KF3096MD4	U2KV23DBUH2	TLR22P2500	ACR70A0H29	DCR80A0H58	ACR62A0H05
U2KX37K0S	300	100	CL07	PR3110STD	U2KV23DBUH3	TLR18P3000	ACR90A0H22	DCR100A0H49	ACR90A0H05
U2KX45K0S	400	100	CL09	PR3150STD	U2KV23DBUH3	TLR15P3700	ACR115A0H18	DCR125A0H40	ACR115A0H05
U2KX55K0S	400	150	CK75	PR3180STD	2 x U2KV23DBUH2	-	ACR115A0H18	DCR140A0H32	ACR115A0H05
U2KX75K0S	500	200	CK08	PR3280STD	UADOPTDBUH0	-	ACR160A0H14	DCR180A0H25	ACR160A0H05
U2KX90K0S	700	300	CK85	PR3280STD	UADOPTDBUH0	-	ACR185A0H11	DCR210A0H25	ACR185A0H05
U2KX110KS	800	300	CK09	PR3330STD	UADOPTDBUH0	-	ACR225A0H096	DCR270A0H18	ACR225A0H05
U2KX132KS	800	350	CK09	PR3380STD	UADOPTDBUH0	-	ACR300A0H067	DCR310A0H14	ACR300A0H05
U2KX160KS	1200	400	CK95	PR3450STD	UADOPTDBUH0	-	ACR360A0H056	DCR400A0H13	ACR360A0H05
U2KX200KS	1600	500	CK10	PR3660STD	UADOPTDBUH0	-	ACR460A0H044	DCR540A0H08	ACR460A0H05
U2KX250KS	2000	700	CK11	PR3750STD	UADOPTDBUH0	-	ACR550A0H039	DCR650A0H07	ACR550A0H05
U2KX315KS	2000	800	CK12	PR3900STD	UADOPTDBUH0	-	ACR625A0H035	DCR740A0H06	ACR625A0H05

**(Note 1)** Device selection conditions

- The input current is calculated as follows:  $I = (kW) / (\eta_M \times \eta_{INV} \times \text{COS}\phi \times \text{Voltage} \times \sqrt{3})$
- The  $\eta_M$  (motor efficiency) is 0.8 for 11kW or less, 0.85 for 15kW or more.
- The  $\eta_{INV}$  (inverter efficiency) is 0.95.
- $\text{COS}\phi$  (input power factor) is 0.9.
- The power supply voltage is 220V/440V.

**(Note 2)** To comply with UL using the 400V Series, use a Class J fuse.

**(Note 3)** Use MCCB with magnetic trip only

**(Note 4)** EMC Filters are shown in section 7-5 (Electromagnetic Compliance, EMC)

**(Note 5)** These are external braking resistors for optimal performance. Drives with built in DB include built in resistance as well. Check chapter 7-4-1.

Braking resistors for drives larger than 45kW are not standard items. Ask your dealer

**(Note 6)** The Surge absorber -useful when length of motor cable is more than 30mts- is configured using the output reactor shown in above table plus RC filter, either N11P34018=7 (use up to 4kHz carrier frequency) or N11P34018=6 (use up to 8kHz carrier frequency)

## 7. Options

**Table 7-2 Main circuit wiring device ratings and stand-alone option types (1) (4)**

### VARIABLE TORQUE RATINGS

VAT2000 VT Ratings	Fuse (2) (A)	MCC (3) (A)	Line MC	EMC Filter	Dynamic Braking Module	Braking Resistor (5)	INPUT AC Reactor	DC Reactor	Surge Absorber (6)
									Out. Reactor
U2KN00K4S	20	5	CL00	U2KF3016MD1	Built in	TLR405P200	ACR6A2H5	-	-
U2KN00K7S	50	10	CL00	U2KF3016MD1	Built in	TLR216P200	ACR9A1H3	-	-
U2KN01K5S	60	15	CL00	U2KF3016MD1	Built in	TLR108P200	ACR12A0H84	-	-
U2KN02K2S	110	20	CL01	U2KF3030MD1	Built in	TLR74P200	ACR18A0H56	-	-
U2KN04K0S	125	30	CL02	U2KF3030MD1	Built in	TLR44P600	ACR27A0H37	-	-
U2KN05K5S	225	40	CL04	U2KF3060MD2	Built in	TLR29P600	ACR35A0H27	DCR45A0H55	-
U2KN07K5S	225	75	CL04	U2KF3060MD2	Built in	TLR22P600	ACR55A0H18	DCR60A0H4	-
U2KN11K0S	250	75	CL06	U2KF3094MD3	U2KV23DBUL1	TLR15P1000	ACR70A0H14	DCR80A0H3	-
U2KN15K0S	400	100	CL07	U2KF3094MD3	U2KV23DBUL1	TLR11P1200	ACR80A0H14	DCR100A0H24	-
U2KN18K5S	500	150	CL09	PR3120STD	U2KV23DBUL2	TLR8,8P1500	ACR97A0H11	DCR120A0H2	-
U2KN22K0S	500	150	CL10	PR3150STD	U2KV23DBUL2	TLR7,4P1800	ACR140A0H072	DCR150A0H17	-
U2KN30K0S	600	200	CK75	PR3150STD	U2KV23DBUL3	TLR5P2500	ACR180A0H056	DCR180A0H14	-
U2KN37K0S	600	200	CK75	PR3180STD	U2KV23DBUL3	TLR4P3000	ACR200A0H051	DCR220A0H11	-
U2KX00K4S	10	5	CL00	U2KF3016MD1	Built in	TLR864P200	ACR3A8H1	-	ACR3A0H05
U2KX00K7S	20	5	CL00	U2KF3016MD1	Built in	TLR864P200	ACR4A5H1	-	ACR4A0H05
U2KX01K5S	30	5	CL00	U2KF3016MD1	Built in	TLR432P200	ACR6A3H4	-	ACR6A0H05
U2KX02K2S	50	15	CL00	U2KF3016MD1	Built in	TLR295P200	ACR10A2H	-	ACR10A0H05
U2KX04K0S	60	20	CL00	U2KF3016MD1	Built in	TLR175P600	ACR14A1H4	-	ACR14A0H05
U2KX05K5S	90	30	CL02	U2KF3032MD2	Built in	TLR118P600	ACR18A1H1	DCR25A2H1	ACR18A0H05
U2KX07K5S	110	40	CL04	U2KF3032MD2	Built in	TLR86P600	ACR27A0H75	DCR32A1H6	ACR27A0H05
U2KX11K0S	125	40	CL04	U2KF3058MD3	U2KV23DBUH1	TLR59P1000	ACR35A0H58	DCR40A1H2	ACR35A0H05
U2KX15K0S	175	50	CL04	U2KF3058MD3	U2KV23DBUH1	TLR43P1000	ACR38A0H58	DCR50A0H96	ACR38A0H05
U2KX18K5S	225	50	CL06	U2KF3058MD3	U2KV23DBUH2	TLR35P1500	ACR45A0H45	DCR60A0H82	ACR45A0H05
U2KX22K0S	250	75	CL06	U2KF3096MD4	U2KV23DBUH2	TLR29P1800	ACR70A0H29	DCR80A0H58	ACR62A0H05
U2KX30K0S	300	100	CL07	U2KF3096MD4	U2KV23DBUH3	TLR22P2500	ACR90A0H22	DCR100A0H49	ACR90A0H05
U2KX37K0S	400	100	CL09	PR3150STD	U2KV23DBUH3	TLR18P3000	ACR90A0H22	DCR125A0H40	ACR90A0H05
U2KX45K0S	400	150	CL09	PR3180STD	2 x U2KV23DBUH2	TLR15P3700	ACR115A0H18	DCR140A0H32	ACR115A0H05
U2KX55K0S	500	200	CK75	PR3280STD	UADOPTDBUH0	-	ACR160A0H14	DCR180A0H25	ACR160A0H05
U2KX75K0S	700	300	CK08	PR3280STD	UADOPTDBUH0	-	ACR185A0H11	DCR210A0H25	ACR185A0H05
U2KX90K0S	800	300	CK85	PR3330STD	UADOPTDBUH0	-	ACR225A0H096	DCR270A0H18	ACR300A0H05
U2KX110KS	800	350	CK09	PR3380STD	UADOPTDBUH0	-	ACR300A0H067	DCR310A0H14	ACR300A0H05
U2KX132KS	1200	400	CK09	PR3450STD	UADOPTDBUH0	-	ACR360A0H056	DCR400A0H13	ACR360A0H05
U2KX160KS	1600	500	CK95	PR3660STD	UADOPTDBUH0	-	ACR460A0H056	DCR540A0H08	ACR460A0H05
U2KX200KS	2000	700	CK10	PR3750STD	UADOPTDBUH0	-	ACR550A0H039	DCR650A0H07	ACR550A0H05
U2KX250KS	2000	800	CK11	PR3900STD	UADOPTDBUH0	-	ACR625A0H035	DCR740A0H06	ACR625A0H05
U2KX315KS	2600	900	CK12	PR3900STD	UADOPTDBUH0	-	ACR700A0H035	DCR800A0H06	ACR700A0H05

**(Note 1)** Device selection conditions

- The input current is calculated as follows:  $I = (kW) / (\eta_M \times \eta_{INV} \times \cos\phi \times \text{Voltage} \times \sqrt{3})$
- The  $\eta_M$  (motor efficiency) is 0.8 for 11kW or less, 0.85 for 15kW or more.
- The  $\eta_{INV}$  (inverter efficiency) is 0.95.
- $\cos\phi$  (input power factor) is 0.9.
- The power supply voltage is 220V/440V.

**(Note 2)** To comply with UL using the 400V Series, use a Class J fuse.

**(Note 3)** Use MCCB with magnetic trip only

**(Note 4)** EMC Filters are shown in section 7-5 (Electromagnetic Compliance, EMC)

**(Note 5)** These are external braking resistors for optimal performance. Drives with built in DB, include built in resistance as well. Check chapter 7-4-1.

Braking resistors for drives larger than 45kW are not standard items. Check chapter 7-4-3.

**(Note 6)** The Surge absorber -useful when length of motor cable is more than 30mts- is configured using the output reactor shown in above table plus RC filter, either N11P34018=7 (use up to 4kHz carrier frequency) or N11P34018=6 (use up to 8kHz carrier frequency)

7-2 VAT2000's main option

VAT2000 catalog numbers U2KxxxKxD, are for DC supply, allowing configurations in common bus.

(1) U2KX00K4D – U2KX37K0D, U2KN00K4D – U2KN07K5D

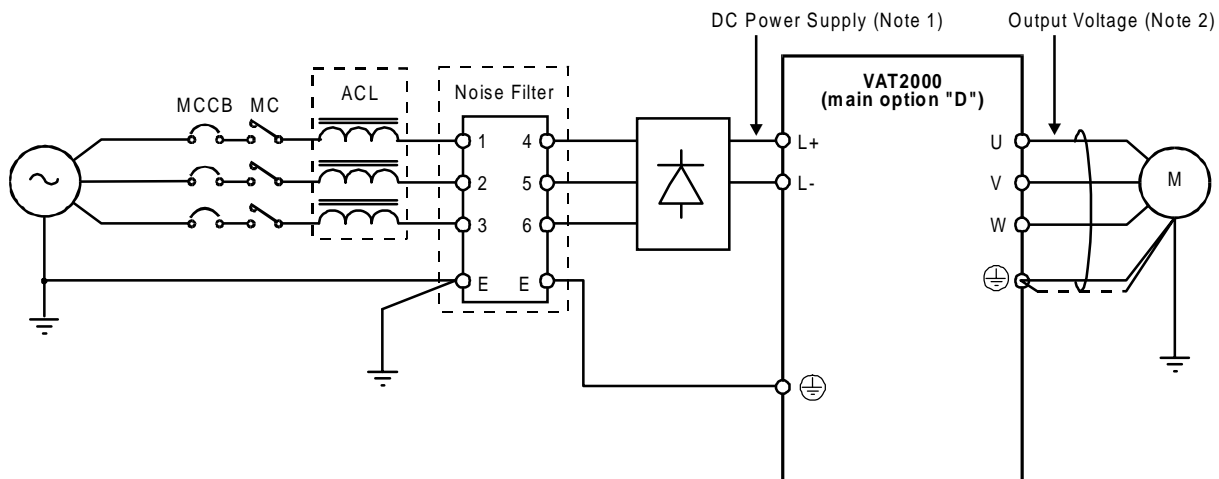

(2) U2KX45K0D, U2KN11K0D – U2KN37K0D

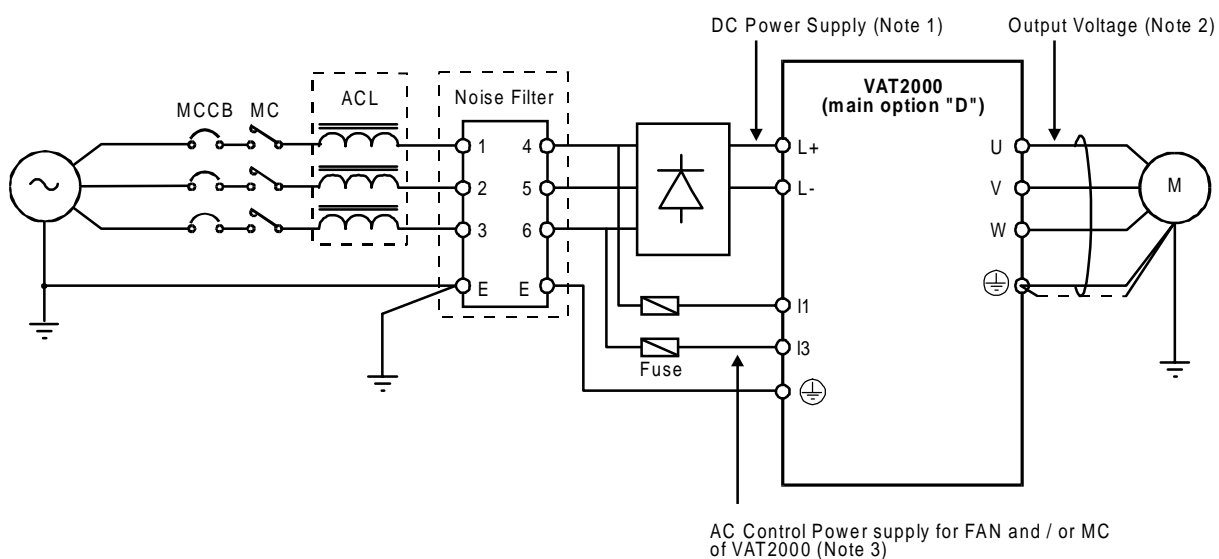

**(Note 1)** DC Power Supply Voltage  
 "X" type 520V-720V DC  
 "N" type 270V-360V DC

**(Note 2)** Output Voltage  
 "X" type Max. 480V AC  
 "N" type Max. 230V AC  
 An output voltage exceeding the DC supply voltage / 1.35, can not be attained.

**(Note 3)** AC Control power supply for FAN and/or MC of VAT2000  
 "X" type 380V-460V ± 10% 50/60Hz ± 5%, 480V + 5% 50/60Hz ± 5%,  
 "N" type 200V-230V ± 10% 50/60Hz ± 5%

### 7-3 Built in PCB option

This is a built-in type option mounted on the VAT2000 control PCB.

As shown in table 7-1, there are three type of option PCBs, option I, option II and option III. The VAT2000 allows mounting up to three cards, but only one of each type.

These PCB options can be easily mounted after purchasing the VAT2000 by the end user.

\* The PCB option cover is required when the PCB option is mounted.

Refer to each instruction manual for details on the PCB options.

#### 7-3-1 Option classes

##### (1) Option I

This is a PCB option for speed detection during IM vector control with speed sensor and PM drive control. The mounting position is fixed.

\* The PM drive control is applicable for the standard PM motor.

##### (2) Option II

This is the PCB option for an analog interface, etc. The mounting position is fixed.

##### (3) Option III

This is the PCB option for the relay interface, etc.

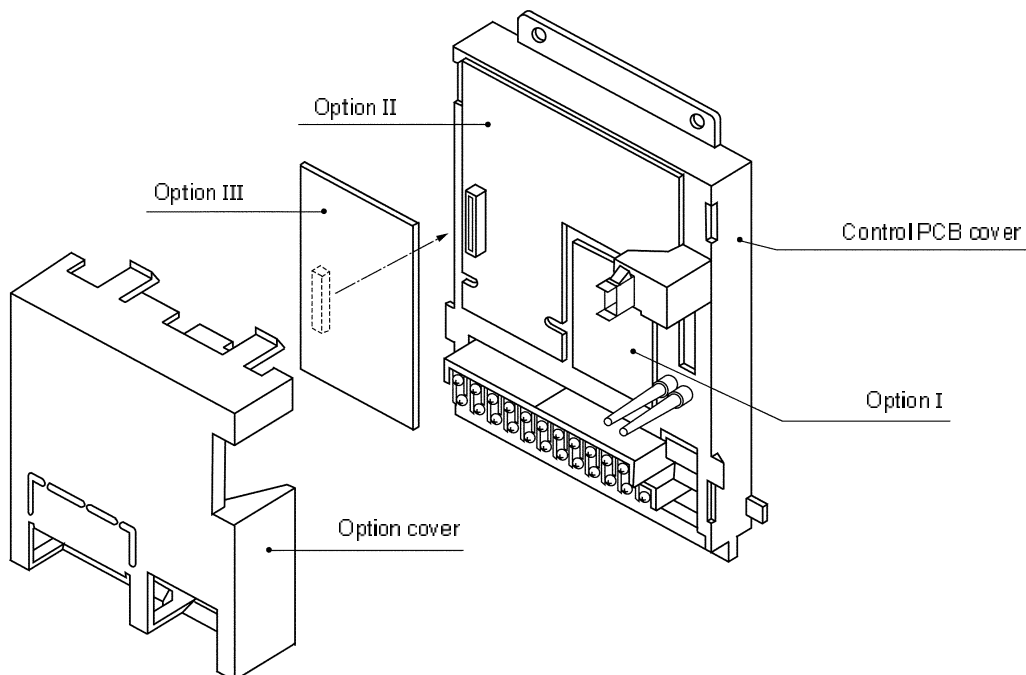

**Built-in PCB option mounting drawing**

**7-4 Dynamic braking (DBR).**

The VAT2000 includes a dynamic braking feature in drives up to U2KN07K5S and U2KX07K5S. When this function is used, set C22-3 accordingly.

For larger drives the dynamic braking is achieved by using external modules. In this case set C22-3=0.0

**7-4-1 Units U2KN07K5S and smaller, and U2KX07K5S and smaller**

These drives include a dynamic braking feature and a DB resistor as standard. The DBR device, allows operation cycle of 10% ED as shown in Fig. 7-2.

When using the dynamic braking option, set parameter B18-1, and C31-0, accordingly.

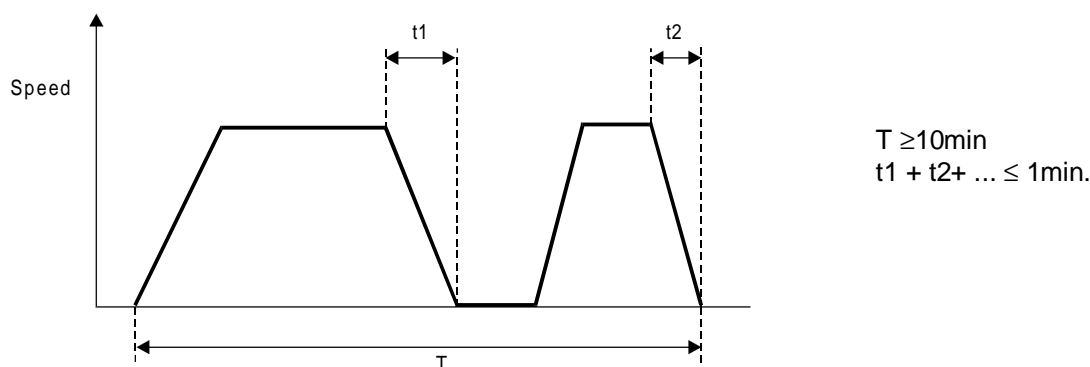

Fig. 7-2

**(1) Unit built-in DBR**

The wiring of resistor built into the unit is shown in Fig. 7-3, and ratings are shown in table 7-3. Because of space restrictions, these resistors do not allow 100% of braking torque in some cases.

Table 7-3

Device type U2KN	Resistance capacity (W)	Resistance value (Ω)	Braking torque (%) (1)	Max. t1 (SEC)	Device type U2KX	Resistance capacity (W)	Resistance value (Ω)	Braking torque (%)	Max. t1 (SEC)
00K4S	120	220	180	30	00K4S	120	430	300	10
00K7S	120	220	100	30	00K7S	120	430	200	10
01K5S	120	220	50	30	01K5S	120	430	100	10
02K2S	120	180	40	20	02K2S	120	430	65	10
04K0S	120	110	40	10	04K0S	120	430	40	10
05K5S	120	91	30	10	05K5S	120	430	25	10
07K5S	120	91	25	10	07K5S	120	430	20	10

**(Note 1)** The braking torque is given for constant torque ratings. When using variable torque ratings, the braking torque is the value given for one frame smaller drive.

**(2) External DBR**

If the braking torque or ED are insufficient with the above built-in resistor, provide an external resistor wired as shown in Fig. 7-3. When using an external DBR, remove the built-in DBR. The resistance value to obtain a 100% braking torque is shown in Table 7-4.

When using the external DBR resistor, it is recommended the use of a thermal relay (76D), to prevent burning as shown in Fig. 7-3

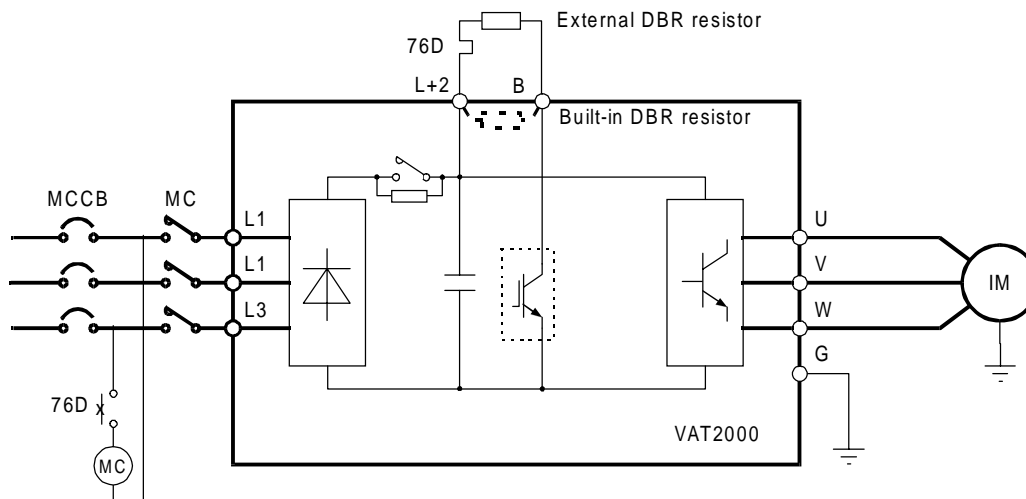

**Fig. 7-3 DBR circuit**

**7-4-2 Units from U2KN11K0S to U2KN37K0S, and from U2KX11K0S to U2KX45K0S.**

When carrying out dynamic braking with the unit from U2KN11K0S to U2KN37K0S, or from U2KX11K0S to U2KX45K0S, an external dynamic braking unit U2KV23DBUxx must be used. Choose the unit according to table 7-2

Connect the DBR unit as shown in Fig. 7-4. In some cases more than one unit can be wired in parallel, check table 7-2 and manual PCST3299E for U2KV23DBU device.

Set in VAT2000 the parameters , C31-0=2 or 4, C22-3=0, B18-1=100%, B25-1=100%.

Set in module U2KV23DBU the parameters A0.x and A1.x at least. Check manual of U2KV23DBU.

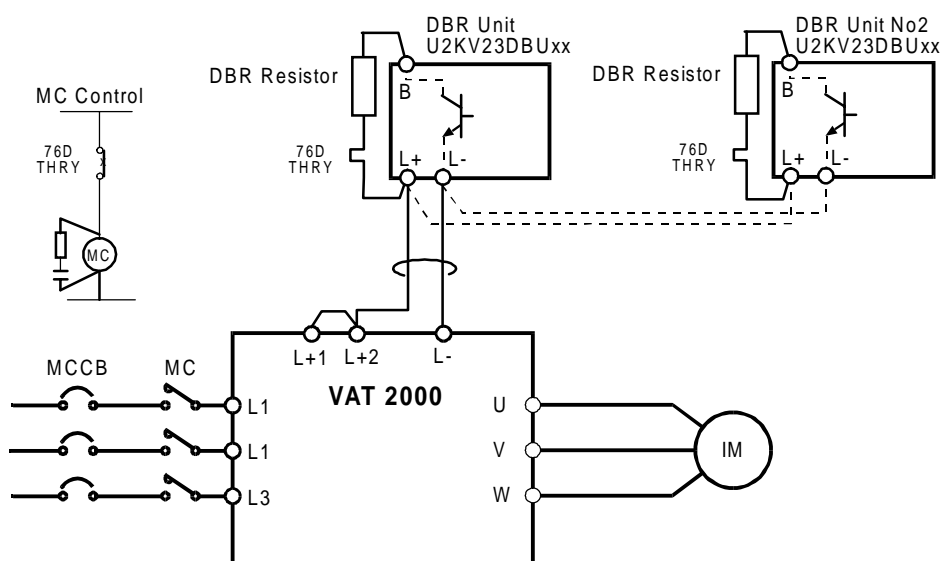

**Fig. 7-4 DBR connection**

## 7. Options

The resistance value to obtain a 100% braking torque is shown in Table 7-4.

**Table 7-4**

VAT2000 type	100% Torque Resistance (Ω)	Resistance (Note1)	Wire (mm <sup>2</sup> )	Dimensions						Type
				A	B	C	D	E	G	
U2KN00K4	405	TLR405P200	2.5	215	80	235	40 ∅	-	-	1(*)
U2KN00K7	216	TLR216P200	2.5	215	80	235	40 ∅	-	-	1(*)
U2KN01K5	108	TLR108P200	2.5	215	80	235	40 ∅	-	-	1(*)
U2KN02K2	74	TLR74P200	2.5	215	80	235	40 ∅	-	-	1(*)
U2KN04K0	44	TLR44P600	2.5	430	95	460	57	-	-	1
U2KN05K5	29	TLR29P600	2.5	430	95	460	57	-	-	1
U2KN07K5	22	TLR22P600	2.5	430	95	460	57	-	-	1
U2KN11K0	15	TLR15P1000	2.5	430	105	460	66	-	-	1
U2KN15K0	11	TLR11P1200	4	430	125	460	80	-	-	1
U2KN18K5	9	TLR8,8P1500	4	430	105	460	139	105	65	2
U2KN22K0	7	TLR7,4P1800	6	430	105	460	139	105	65	2
U2KN30K0	5	TLR5P2500	16	430	105	460	207	185	136	2
U2KN37K0	4	TLR4P3000	16	410	180	430	139	119	68	2
U2KX00K4	864	TLR864P200	2.5	215	80	235	40 ∅	-	-	1(*)
U2KX00K7	864	TLR864P200	2.5	215	80	235	40 ∅	-	-	1(*)
U2KX01K5	432	TLR432P200	2.5	215	80	235	40 ∅	-	-	1(*)
U2KX02K2	295	TLR295P200	2.5	215	80	235	40 ∅	-	-	1(*)
U2KX04K0	175	TLR175P600	2.5	430	95	460	57	-	-	1
U2KX05K5	118	TLR118P600	2.5	430	95	460	57	-	-	1
U2KX07K5	86	TLR86P600	2.5	430	95	460	57	-	-	1
U2KX11K0	59	TLR59P1000	2.5	430	105	460	66	-	-	1
U2KX15K0	43	TLR43P1000	2.5	430	105	460	66	-	-	1
U2KX18K5	35	TLR35P1500	2.5	430	105	460	139	105	65	2
U2KX22K0	29	TLR29P1800	4	430	105	460	139	105	65	2
U2KX30K0	22	TLR22P2500	6	430	105	460	207	185	136	2
U2KX37K0	18	TLR18P3000	16	410	180	430	139	119	68	2
U2KX45K0	15	TLR15P3700	16	410	180	430	139	119	68	2

**Note 1** Recommended resistor is rated for a ED of 10%, with maximum braking time of 20 sec. For braking large inertia loads, ask your supplier for an appropriate resistor. Note that VAT2000 up to U2KN07K5S and U2KX07K5S, include DB resistor as shown in table 7-3. This should be disconnected when using external resistors

**Type 1(\*)** As type 1, but provided with 210mm output cable (No terminals)

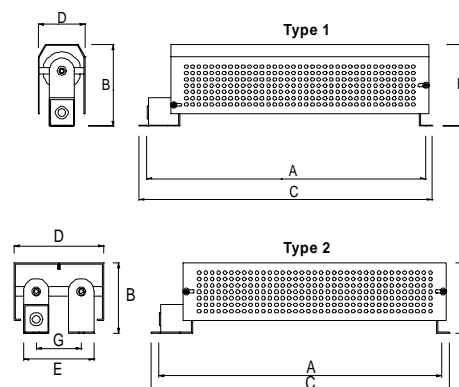
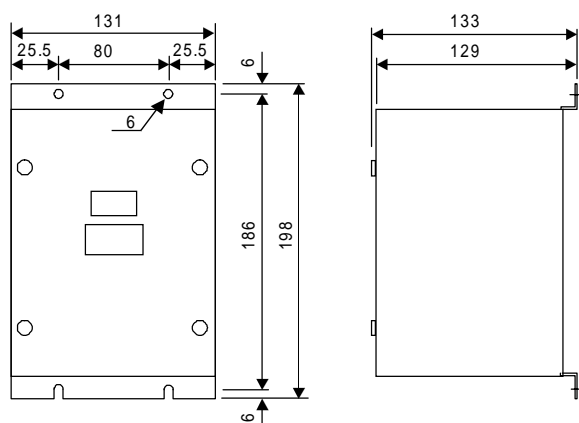

**Dynamic Braking module U2KV23DBU (mm)**

**External Braking resistors**

7-4-3 Large units from U2KX55K0S to U2KX315K0.

1. When carrying out dynamic braking with the a VAT2000 larger than U2KX55K0S, connect the Braking module UADOPTDBUHO as shown in Fig 7-5. This module should be used at 10% ED or less as shown in Fig 7-2. One or two units in parallel can be used.
2. Connect the inverter control terminals RA-RC to Braking unit terminals 1-2. The DB will function when the VAT2000 runs then.

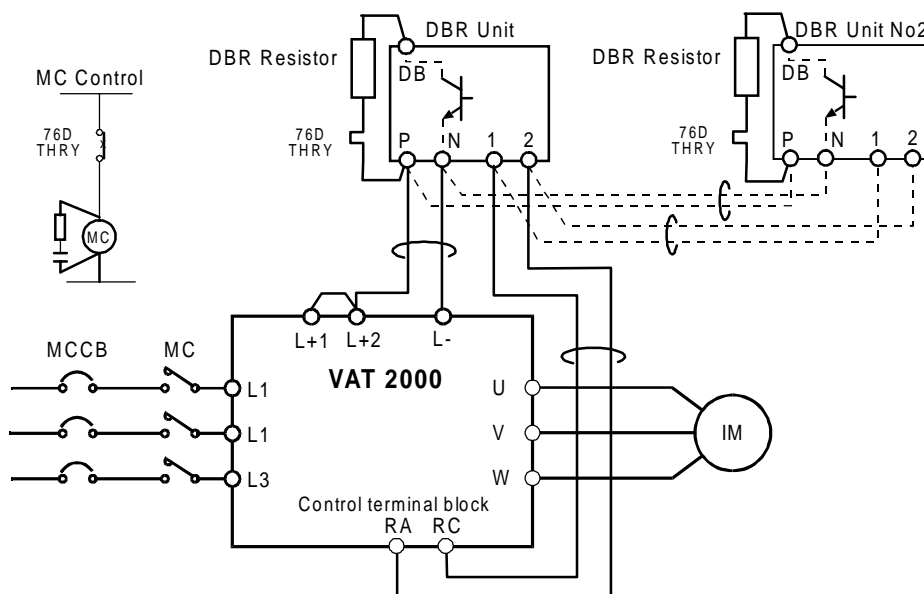

Fig 7-5

3. Set the following parameters on VAT2000 when using the Dynamic Braking module UADOPTDBUHO.  
 C31-0=2 or 4  
 C13-2=0; RA-RC output is assigned to RUN function.  
 B18-1=100%; Regenerative current limit  
 B25-1=100%; Regenerative current limit for auxiliary drive (if used only)
4. Obtain the power generation capacity and DBR resistance value with the following expressions.

$$\text{Power generation capacity [KW]} = \frac{\text{Regenerative Torque}}{\text{Motor Rated Torque}} \times 0,8 \times \text{Motor Capacity [KW]}$$

$$\text{DBR resistance value} = \frac{K}{\text{Power generation capacity [KW]}}$$

For VAT2000, 400V series, **K=593**

5. The minimum resistance value of the resistor that can be connected to the DBR unit is 3,3 Ohms. If lower values are required use two DB units in parallel

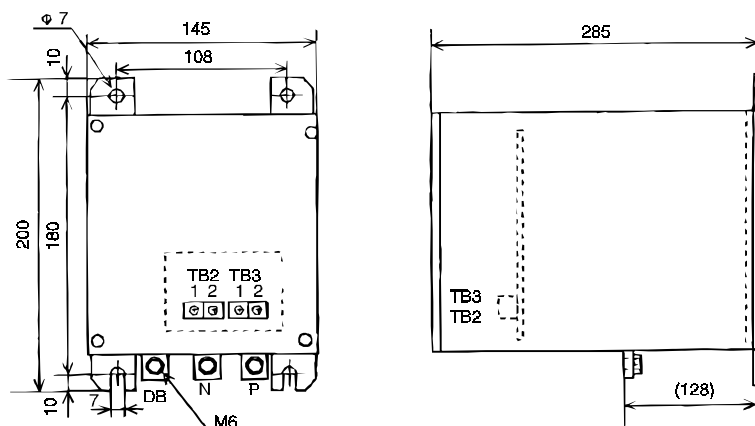

Fig 7-2  
UADOPTDBUHO dimensions

### 7-5 Electro Magnetic Compliance, EMC

Electromagnetic Compliance with the EN50081 & EN50082 is achieved by using appropriate EMC filters. EMC foot print filters can be mounted on the drive's foot saving space in cabinets, or alternatively along side the drive when the total depth is a problem.

Details of Foot print and Stand alone filters are given below.

#### (1) Foot-print filters

EMC Filter Part No	Current	Dimensions				Input Term.
		L x W x H	X x Y	M		
U2KF3016MD1	16A	288x175x51	273x100	M5	10mm2	
U2KF3030MD1	30A	288x175x51	273x100	M5	10mm2	
U2KF3032MD2	32A	320x221x51	305x150	M5	10mm2	
U2KF3058MD3	58A	427x275x66	402x225	M5	10mm2	
U2KF3060MD2	60A	320x221x51	305x150	M5	25mm2	
U2KF3094MD3	94A	427x275x66	402x225	M5	35mm2	
U2KF3096MD4	96A	575x312x67	549x200	M5	35mm2	

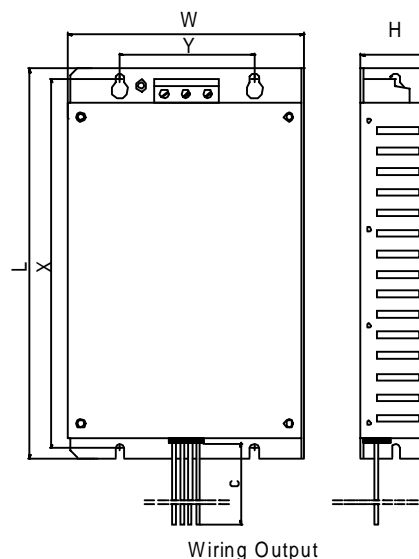

#### (2) Stand Alone EMC filters

EMC Filter Part No	Current	Dim.	Term.
PR3110STD	110A	fig 1	50 mm <sup>2</sup>
PR3120STD	120A	fig 1	50 mm <sup>2</sup>
PR3150STD	150A	fig 2	95 mm <sup>2</sup>
PR3180STD	180A	fig 2	95 mm <sup>2</sup>
PR3280STD	280A	fig 3	150 mm <sup>2</sup>
PR3330STD	330A	fig 4	Bar 25x6
PR3380STD	380A	fig 4	Bar 25x6
PR3450STD	450A	fig 4	Bar 25x6
PR3660STD	660A	fig 4	Bar 30x8
PR3750STD	750A	fig 4	Bar 40x10
PR3900STD	900A	fig 4	Bar 40x10

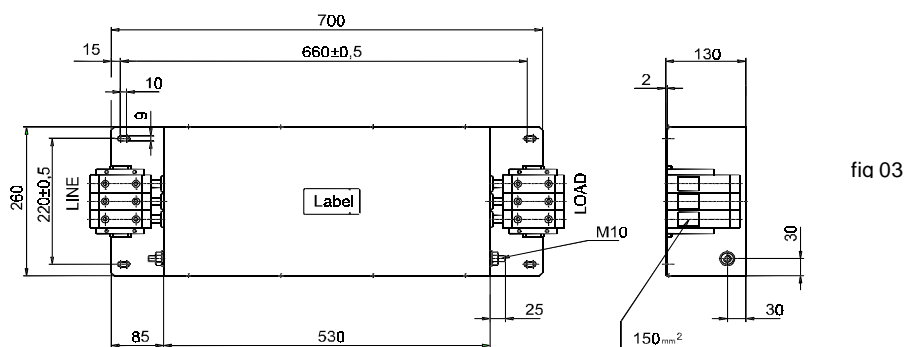
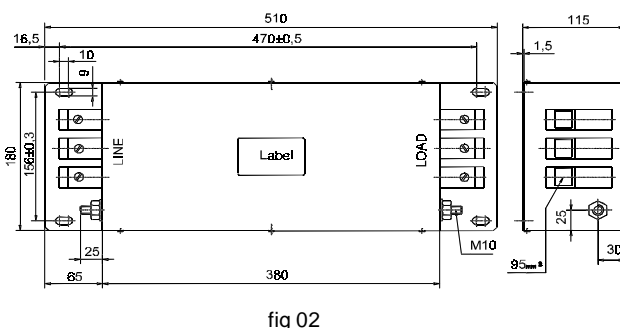
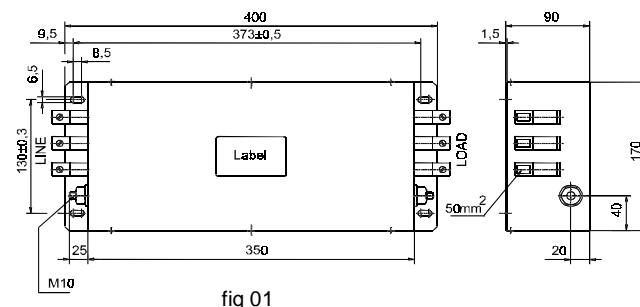

## 7. Options

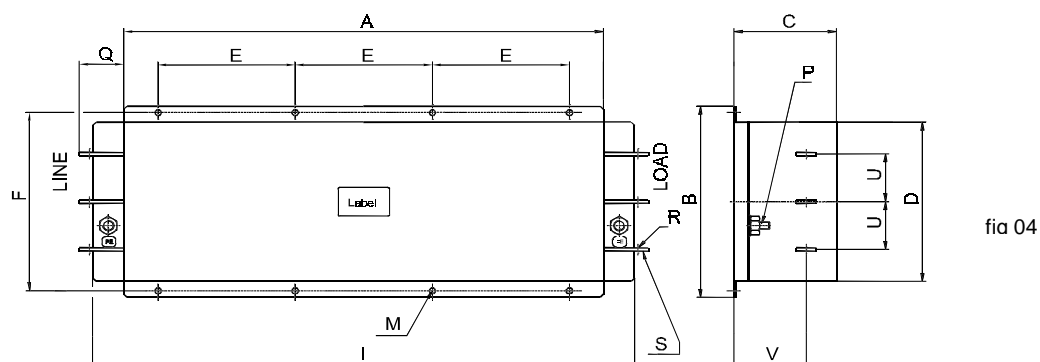

	A	B	C	D	E	F	I	M	P	Q	R	S	U	V
PR3330STD	700	300	150	250	200	280	790	9	M16	65	12,5	25x6	75	105
PR3380STD	700	300	150	250	200	280	790	9	M16	65	12,5	25x6	75	105
PR3450STD	700	300	150	250	200	280	790	9	M16	65	12,5	25x6	75	105
PR3600STD	700	300	150	250	200	280	790	9	M16	85	12,5	30x8	75	105
PR3750STD	556	430	215	360	150	400	680	13	M20	122	17	40x10	90	115
PR3900STD	556	430	215	360	150	400	680	13	M20	122	17	40x10	90	115
Tol mm.	±2	±3	±2	±2	±0,5	±0,2	±3	-	-	±3	±0,3	-	±1	-

### (3) Recommended Installation instructions for Electro Magnetic Compliance

An inverter has not intrinsic on its own, but is considered as a component to be installed with other control components. It should be possible to achieve EMC for the machinery controlled by the inverter by following the guidelines below.

1. Check the filter and inverter rating labels to ensure that the part numbers are correct.
2. Ensure the best possible earthing of the filter.
3. Both filter and inverter have to be securely mounted.
4. Connect the incoming mains supply to the filter terminals marked "lines", connect any earth cables to the earth stud provided. Connect the filter terminals marked "LOAD" to the mains supply of the inverter using short lengths of appropriate gauge cable.
5. Connect the motor by means of armoured or screened cable. The earth conductor should be securely earthed at both inverter and motor ends and the screen should be connected to the enclosure body.

It is important that the lead length from filter to inverter and unscreened length of motor output cable be kept as short as possible and that incoming mains and outgoing cables are kept well separated.

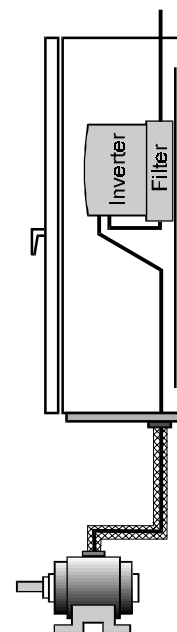

7-6 Reactors

(1) Input Reactors

Input reactor usage is shown on Table 7-1 and 7-2, for both CT and VT ratings. Other details are given below.

Catalog #	Losses W	DIMENSIONS (mm)							Weight (kg)
		Drawing	A	B	C	D	E	O	
ACR4A2H5	9	Fig.01	137	146	103	125	102	7	2,9
ACR6A2H5	11	Fig.01	137	146	103	125	102	7	3,2
ACR9A1H3	14	Fig.01	137	146	113	125	102	7	4
ACR12A0H84	19	Fig.01	173	167	118	146	127	7	8
ACR18A0H56	21	Fig.01	173	167	133	146	127	7	10
ACR27A0H37	23	Fig.01	205	200	145	176	174	7	12
ACR35A0H27	25	Fig.01	205	200	155	176	174	7	13
ACR55A0H18	28	Fig.01	205	200	155	176	174	7	13
ACR70A0H14	32	Fig.02	280	190	210	80	250	9	20
ACR80A0H14	35	Fig.02	280	190	210	80	250	9	20
ACR97A0H11	39	Fig.02	280	190	210	80	250	9	20
ACR140A0H072	40	Fig.03	280	220	210	90	250	9	22
ACR180A0H056	42	Fig.03	280	230	210	100	250	9	27
ACR200A0H051	47	Fig.03	280	245	210	115	250	9	29
ACR3A8H1	8	Fig.01	137	146	103	125	102	7	2,8
ACR4A5H1	9	Fig.01	137	146	103	125	102	7	2,9
ACR6A3H4	11	Fig.01	137	146	103	125	102	7	3,2
ACR10A2H	14	Fig.01	137	146	113	125	102	7	4
ACR14A1H4	19	Fig.01	173	167	118	146	127	7	8
ACR18A1H1	21	Fig.01	173	167	133	146	127	7	10
ACR27A0H75	23	Fig.01	205	200	145	176	174	7	12
ACR35A0H58	25	Fig.01	205	200	155	176	174	7	13
ACR38A0H58	32	Fig.01	205	200	170	176	174	7	14
ACR45A0H45	35	Fig.01	205	200	170	176	174	7	14
ACR70A0H29	40	Fig.02	280	200	210	90	250	9	22
ACR90A0H22	42	Fig.02	280	210	210	100	250	9	27
ACR115A0H18	47	Fig.02	280	225	210	100	250	9	29
ACR160A0H14	51	Fig.03	340	230	265	106	310	9	38
ACR185A0H11	53	Fig.03	340	250	265	126	310	9	43
ACR225A0H096	58	Fig.03	340	250	265	126	310	9	45
ACR300A0H067	75	Fig.03	410	320	315	136	380	9	81
ACR360A0H056	78	Fig.03	410	320	315	136	380	9	86
ACR460A0H056	107	Fig.03	490	340	365	142	460	9	97
ACR550A0H039	110	Fig.03	490	340	365	142	460	9	98
ACR625A0H035	120	Fig.03	490	340	365	142	460	9	101
ACR700A0H035	130	Fig.03	490	340	365	142	460	9	105

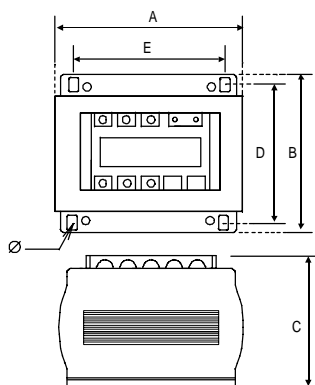

Fig .01

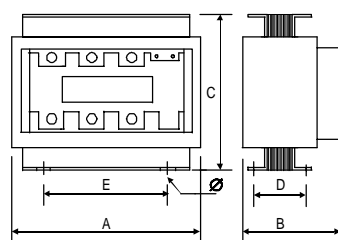

Fig .02

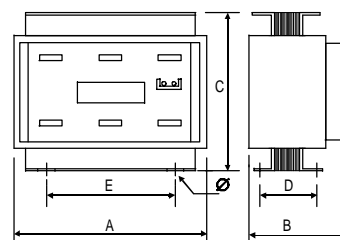

Fig .03

## 7. Options

### (2) DCR Reactors

DC Bus reactor usage is shown on Table 7-1 and 7-2, for both CT and VT ratings. Other details are given below.

Catalog #	Losses W	DIMENSIONS (mm)							Weight (kg)
		Drawing	A	B	C	D	E	O	
DCR32A0H78	13	Fig.04	150	200	145	176	102	7	7
DCR45A0H55	13	Fig.04	150	200	145	176	102	7	7
DCR60A0H4	14	Fig.04	150	200	155	176	102	7	8
DCR80A0H3	17	Fig.04	150	200	170	176	102	7	9
DCR100A0H24	17	Fig.04	150	200	170	176	102	7	9
DCR120A0H2	17	Fig.05	190	200	215	90	160	9	15
DCR150A0H17	21	Fig.05	190	210	215	100	160	9	17
DCR180A0H14	26	Fig.05	240	200	265	96	210	9	21
DCR220A0H11	27	Fig.05	240	200	265	96	210	9	21
DCR18A2H9	13	Fig.04	125	167	118	146	89	7	5
DCR25A2H1	14	Fig.04	125	167	118	146	89	7	5
DCR32A1H6	15	Fig.04	125	167	133	146	89	7	6
DCR40A1H2	17	Fig.04	125	167	133	146	89	7	6
DCR50A0H96	16	Fig.04	150	200	145	176	102	7	7
DCR60A0H82	17	Fig.04	150	200	155	176	102	7	8
DCR80A0H58	21	Fig.04	150	200	170	176	102	7	9
DCR100A0H49	23	Fig.04	150	200	170	176	102	7	9
DCR125A0H40	27	Fig.05	190	200	215	90	160	9	15
DCR140A0H32	29	Fig.05	190	200	215	90	160	9	15
DCR180A0H25	33	Fig.05	250	230	300	106	210	9	25
DCR210A0H25	35	Fig.05	250	340	300	126	210	9	27
DCR270A0H18	37	Fig.05	250	250	300	136	210	9	28
DCR310A0H14	39	Fig.05	250	250	300	136	210	9	31
DCR400A0H13	42	Fig.05	300	270	350	136	260	11	55
DCR540A0H08	49	Fig.05	300	300	350	136	260	11	56
DCR650A0H07	50	Fig.05	300	300	350	136	260	11	57
DCR740A0H06	51	Fig.05	300	300	350	136	260	11	58
DCR800A0H06	52	Fig.05	300	300	350	136	260	11	60

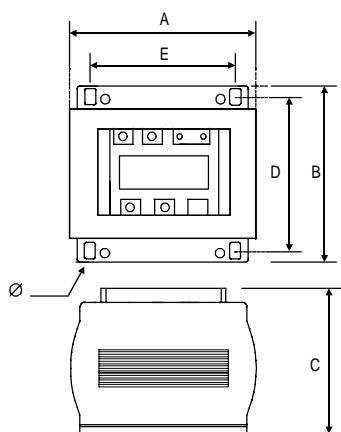

Fig.04

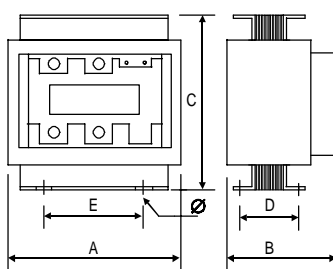

Fig.05

## 7. Options

### (3) Surge absorbers

Surge absorber usage is shown on Table 7-1 and 7-2, for both CT and VT ratings. Other details are given below. Surge absorber is composed by two items, ACR output reactor and RC filters

Catalog # ACR	Losses W	DIMENSIONS (mm)							Weight (kg)
		Drawing	A	B	C	D	E	O	
ACR3A0H05	9	Fig.01	137	146	103	125	102	7	2,9
ACR4A0H05	9	Fig.01	137	146	103	125	102	7	2,9
ACR6A0H05	9	Fig.01	137	146	103	125	102	7	2,9
ACR10A0H05	9	Fig.01	137	146	103	125	102	7	2,9
ACR14A0H05	10	Fig.01	137	146	103	125	102	7	2,9
ACR18A0H05	10	Fig.01	137	146	103	125	102	7	2,9
ACR27A0H05	11	Fig.01	137	146	103	125	102	7	2,9
ACR35A0H05	11	Fig.01	137	146	103	125	102	7	2,9
ACR38A0H05	11	Fig.01	137	146	103	125	102	7	2,9
ACR45A0H05	11	Fig.01	137	146	103	125	102	7	2,9
ACR62A0H05	14	Fig.01	137	146	113	125	102	7	4
ACR90A0H05	21	Fig.01	173	167	133	146	127	7	10
ACR115A0H05	32	Fig.01	205	200	170	176	174	7	14
ACR160A0H05	35	Fig.03	280	210	210	80	250	9	20
ACR185A0H05	39	Fig.03	280	210	210	80	250	9	20
ACR225A0H05	42	Fig.03	280	230	210	100	250	9	27
ACR300A0H05	53	Fig.03	340	250	265	126	310	9	45
ACR360A0H05	78	Fig.03	410	320	315	136	380	9	86
ACR460A0H05	94	Fig.03	490	340	365	142	460	9	97
ACR550A0H05	110	Fig.03	490	340	365	142	460	9	103
ACR625A0H05	120	Fig.03	490	340	365	142	460	9	104
ACR700A0H05	130	Fig.03	490	340	365	142	460	9	106

Catalog # RC	Losses W	Drawing	VAT2000 usage	Weight (kg)
N11P34018=7	297	Fig. 06	Maximum Carrier frequency 4kHz	
N11P34018=6	1470		Maximum Carrier frequency 8kHz	

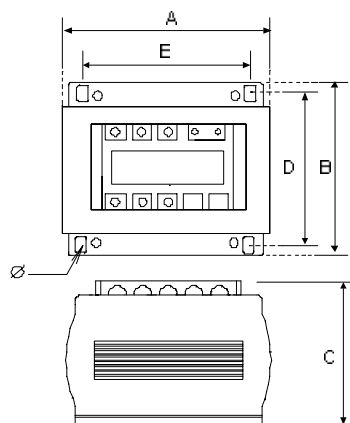

Fig. 01, ACR

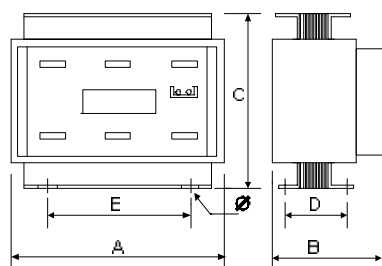

Fig. 02, ACR

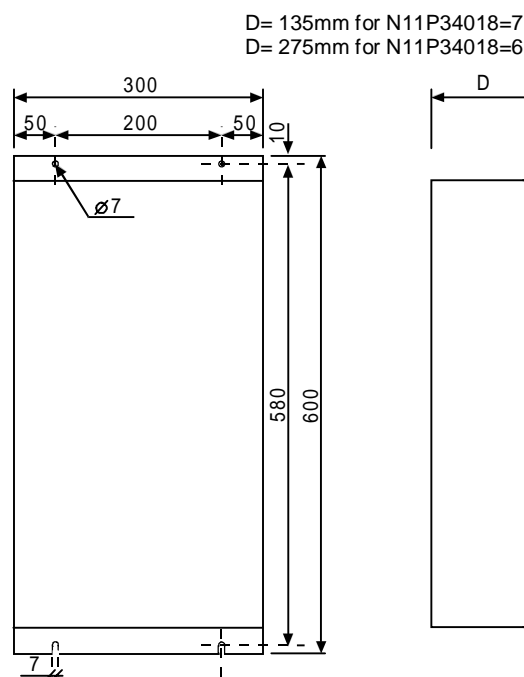

Fig. 06, RC Filter ACR

## Chapter 8 Maintenance and Inspection

### DANGER

- Always wait at least 20 minutes after turning the input power OFF before starting inspections. Wait at least 20 minutes after turning the input power OFF before starting work. Make sure that the displays on the operation panel have gone out before removing the front cover. Remove the front cover, and confirm that the "CHARGE" LED on the drive PCB or at the side of the control PCB has gone out. Also check that the voltage between terminals L+1 or L+2 and L– is 15V or less before starting the inspections. Failure to observe this could lead to electric shocks.
- Maintenance, inspections and part replacement must be done by a designated person. (Remove all metal accessories such as watches, bracelets, etc., before starting the work.) (Always use an insulation measure tool.) Failure to observe this could lead to electric shocks and injuries.
- Always turn the power OFF before inspecting the motor or machine. A potential is applied on the motor terminal even when the motor is stopped. Failure to do so could lead to electric shocks and injuries.
- Do not use parts other than those designated for the replacement parts. Contact your inverter dealer for replacement parts. Failure to observe this could lead to fires.

### CAUTION

- Clean the inverter with a vacuum cleaner. Do not use water or organic solvents. Failure to observe this could lead to fires or damage.

## 8-1 Inspection items

The inspections must be carried out periodically according to the working environment and frequency of use. If there are any abnormalities, the cause must be inspected immediately and countermeasures taken.

### (1) Daily inspections

Table 8-1

Inspection item	Inspection details and work
Temperature/humidity	Confirm that the ambient temperature is –10 to 50°C, and that the humidity is 95% or less with no dew condensation.
Oil mist and dust	Confirm that there is no oil mist or dust in the VAT2000.
Abnormal noise and vibration	Confirm that there is no abnormal noise or vibration from the installation site or VAT2000.
Input power source	Confirm that the input voltage and frequency are within the specifications range.
Cooling fan	Confirm that the cooling fan rotates normally and that no lint, etc. is stuck on it.
Indicator	Confirm that all lamps on the operation panel light properly.

(2) Periodic inspections

Table 8-2

Inspection item	Inspection details and work
VAT2000 appearance	Check the state of dirt and dust on the vent or heatsink, and clean if necessary.
VAT2000 interior	Check the state of dirt and dust on the PCB and inside the equipment, and clean if necessary.
Terminal block	Tighten the terminal block screws if loose.
Cooling fan	Replace the fan every three years.
Electrolytic capacitor	Confirm that there is no liquid leaking or sheath discoloration.
Insulation resistance inspection	Do not perform a megger test on the VAT2000. When doing a megger test on the external circuit, disconnect all wires connected to the VAT2000.
Encoder	Confirm that there is no looseness or play in the bearings or couplings. The bearings are durable parts. This is approx. 10,000 hours at 6000rpm, and approx. 30,000 hours at 3000rpm. They must be replaced periodically.

(3) Inspection of spare VAT2000

The inspection shown in Table 8-2 must also be performed for spare VAT2000 that are left connected but are not used in normal operation. The operation of the VAT2000 must be checked every six months by turning the power on.

8-2 Measuring devices

As the voltage and current on the input and output sides include high harmonics, the measured value will differ according to the measuring device. When measuring with a device for commercial frequencies, measure with the following circuits and noted measuring devices.

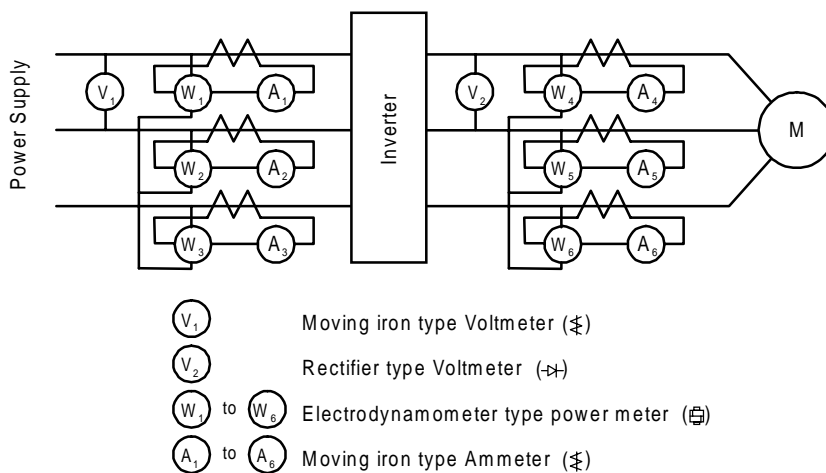

Fig. 8-1 Measurement circuit example

8-3 Protective functions

The VAT2000 has the protective functions shown in Table 8-3.

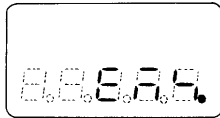
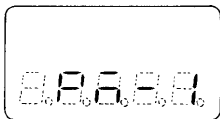
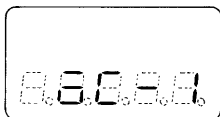

Table 8-3 Protective function

Name	Function
Overcurrent trip (OC-1 to 9)	The output is cut off and the inverter stops if the instantaneous value of the output current exceeds the preset value.
Overvoltage trip (OV-1 to 9)	The output is cut off and the inverter stops if the instantaneous value of the DC voltage in the main circuit exceeds the preset value.
Undervoltage trip (UV-1 to 9)	The output is cut off and the inverter stops if the DC voltage drops to approx. 65% or less due to a power failure or voltage drop during operation.
Overcurrent limit	If an overload occurs, the output frequency is automatically adjusted so that the output current is less than the overcurrent limit (150% as a standard) set with B18-0.
Overvoltage limit	If the output frequency is reduced suddenly, the DC voltage will rise in the main circuit due to the regenerative power. The output frequency will be automatically adjusted to prevent the DC voltage in the main circuit from exceeding the preset value.
Overload trip (OL-1)	The output will be cut off and the inverter will stop if the overload characteristics set with C22-0, 1 and 2 are exceeded. The setting (150% for 1 min. as a standard) can be changed according to the characteristics of the motor.
Overheat (UOH)	A thermistor is installed to detect temperature rises of the heatsink.
Self-diagnosis (IO, dER, CPU)	The built-in CPU, peripheral circuits and data are tested and monitored for abnormalities.
Grounding trip (Grd1 to 9)	The output will be cut off and the inverter will stop if a ground fault is detected.
Power module fault (PM-1 to 9)	The operation of the main circuit power module protection function is detected, and the inverter will stop if a fault is detected.

### 8-4 Troubleshooting with fault display

The countermeasures for when the inverter stops with a fault code display are shown in Table 8-4.

**Table 8-4 Troubleshooting (1)**

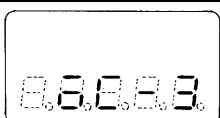
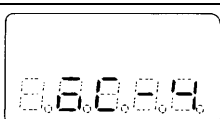
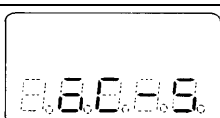
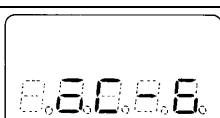
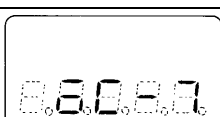
Display symbol	Name	Causes and countermeasures
 EMS.	Emergency stop	1. The sequence input EMS has been activated. Check the signal wiring. 2. This fault occurs when C00-4=2.
 PM-1~PM-9	Power module	1. Indicates that the short circuit protection circuit activated. 2. The sub-codes and causes and countermeasures are the same as for OC-1~9.
 OC-1	Overcurrent during stop	1. The power module in the main circuit may be broken.
 OC-2	Overcurrent during constant speed operation	1. A sudden change in the load or short circuit may have occurred. Reduce the load fluctuation.
 OC-3	Overcurrent during acceleration	1. Increase the acceleration time setting (A01-0). 2. Reduce the torque boost voltage (A02-2). 3. An excess $GD^2$ , short circuit or rapid fluctuation of the load may have occurred.
 OC-4	Overcurrent during deceleration	1. Increase the deceleration time setting (A01-1). 2. A short circuit or rapid fluctuation of the load may have occurred.
 OC-5	Overcurrent during braking	1. Reduce the brake voltage setting (A03-0). 2. A short circuit in the load may have occurred.
 OC-6	Overcurrent during ACR	1. A short circuit in the load may have occurred.
 OC-7	Overcurrent during pre-excitation	



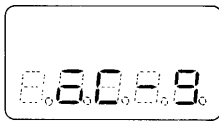
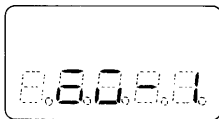
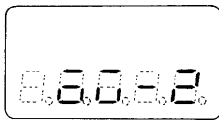
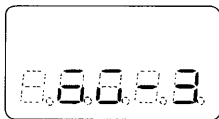
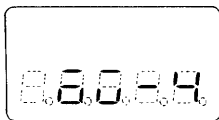
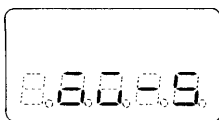
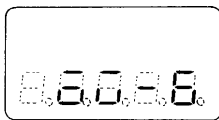
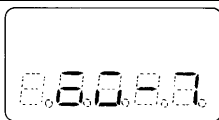
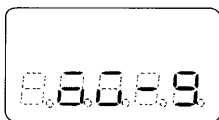

## 8. Maintenance and Inspection

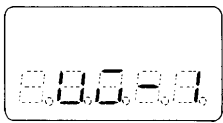
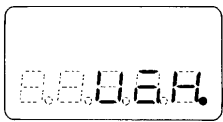
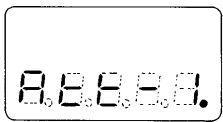
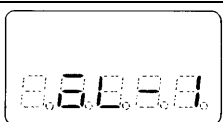
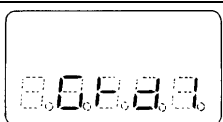
Display symbol	Name	Causes and countermeasures
 <p style="text-align: center;">OC-9</p>	Overcurrent during automatic tuning	<ol style="list-style-type: none"> <li>1. Increase the acceleration time setting (A01-0).</li> <li>2. Increase the deceleration time setting (A01-1).</li> <li>3. A short circuit in the load may have occurred.</li> </ol>
 <p style="text-align: center;">OV-1</p>	Overvoltage during stop	<ol style="list-style-type: none"> <li>1. The power supply voltage may have risen. Reduce the voltage to within the specified range.</li> </ol>
 <p style="text-align: center;">OV-2</p>	Overvoltage during constant speed operation	<ol style="list-style-type: none"> <li>1. The power supply voltage may have risen. Reduce the voltage to within the specified range.</li> <li>2. The speed may be fluctuating.</li> </ol>
 <p style="text-align: center;">OV-3</p>	Overvoltage during acceleration	
 <p style="text-align: center;">OV-4</p>	Overvoltage during deceleration	
 <p style="text-align: center;">OV-5</p>	Overvoltage during braking	<ol style="list-style-type: none"> <li>1. The power supply voltage may have risen. Reduce the voltage to within the specified range.</li> </ol>
 <p style="text-align: center;">OV-6</p>	Overvoltage during ACR	
 <p style="text-align: center;">OV-7</p>	Overvoltage during pre-excitation	
 <p style="text-align: center;">OV-9</p>	Overvoltage during automatic tuning	

## 8. Maintenance and Inspection

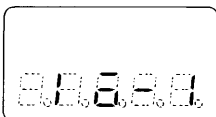
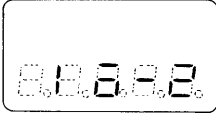
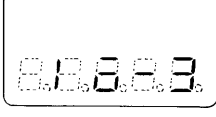
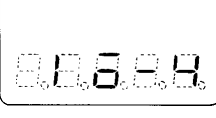
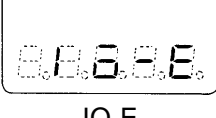
Display symbol	Name	Causes and countermeasures
 UV-1~UV-9	Undervoltage	1. A drop in voltage, phase dropout or power supply failure may have occurred. Check the power supply system and correct if necessary.
 UOH.	Overheat	1. A trouble may have occurred in the cooling fan. Replace if necessary. 2. The ambient temperature may have risen. Lower the ambient temperature. (50°C or less) 3. The fan or heatsink may be clogged. Clean it 4. The carrier frequency may be set too high. Check Appendix Table 1 (note5)
 ATT-n n: Step No.	Automatic tuning abnormal completion	1. n = 1 The motor may not be connected correctly. Check the connection. The B00 and B01 parameters may not be set correctly. Check the parameter settings. 2. n = 2 The B00 and B01 parameters may not be set correctly. Check the parameter settings. 3. n = 3 The load and machine may not be separated. Separate the load and machine. Increase the acceleration time (A01-0). Increase the deceleration time (A01-1). If the motor vibrates, increase the torque stabilising gain (B18-2). 4. n = 4 The load and machine may not be separated. Separate the load and machine. If the motor vibrates, increase the torque stabilising gain (B18-2). 5. n = 5 If the motor does not stop, Increase the acceleration/deceleration time (A01-0, A01-1). If the motor is stopped, the B00 and B01 parameters may not be set correctly. Check the parameter settings. 6. n = 6 The B00 and B01 parameters may not be set correctly. Check the parameter settings..
 OL-1	Overload	1. The motor may be overloaded. Reduce the load or increase the motor and inverter capacity. 2. If this occurs at a low speed, try lowering the boost (A02-2) or brake voltage (A03-0).
 GRD.1~GRD.9	Grounding	1. A ground fault may have occurred in the output line or motor. Restore the grounded point.

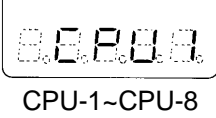
## 8. Maintenance and Inspection

Display symbol	Name	Causes and countermeasures
 IO-1	I/O error (gate turn-off circuit error)	1. The VAT2000 may be malfunctioning due to external noise, etc. Look for the noise source and remove the cause. The control circuit may be faulty.
 IO-2	I/O error (A/D converter error)	
 IO-3	I/O error (current detection error)	1. The current detector connectors may be connected improperly. Properly connect these. 2. The current detection may be faulty.
 IO-4	I/O error (retry time-out)	1. Retry has failed. There are no countermeasures for this code, so reset the VAT2000.
 IO-E	I/O error (thermistor error)	1. Securely connect the thermistor connector.
 IO-F	I/O error (speed detection error)	1. This indicates that there is an error in the speed detection operation results. Check the speed detection signal wiring, connection and the speed detector.
 CPU-1~CPU-8	CPU error	1. The unit may be malfunctioning due to external noise, etc. Look for the noise source and remove the cause. 2. The control circuit may be faulty. 3. For all sub-codes other than 8, turn the power off and on once.
 	EEPROM data error	The parameter setting value is incorrect. Correct the parameter setting value with the following procedure. <ol style="list-style-type: none"> <li>(1) Select D20-2 with the monitor mode, and press the set key. The parameter for which an error occurred will display.</li> <li>(2) Set the correct parameter in this state.</li> <li>(3) Display the parameters in order with the  knob.</li> </ol>

## 8-5 Troubleshooting with no fault display

The causes and countermeasures for errors with no fault display are shown in Table 8-5.

**Table 8-5 Troubleshooting**

Phenomenon	Causes and countermeasures
Motor does not run	<ol style="list-style-type: none"> <li>1. The input/output wiring may be improper, or phase or power failure may have occurred. Inspect and correct the wiring.</li> <li>2. The motor may be locked or the load excessively heavy. Reduce the load.</li> <li>3. The reverse run interlock function (C09-3) may be set or the other parameters may be incorrect. Check the parameters.</li> <li>4. The voltage may not be output to the VAT2000 output terminal. Measure the output voltage, and confirm that the three phases are balanced.</li> <li>5. The local/remote setting may be incorrect. Set according to the required mode.</li> <li>6. The encoder signal may not be input correctly. Check it</li> </ol>
Motor runs in opposite direction	<ol style="list-style-type: none"> <li>1. The output terminals U, V, and W sequence may be incorrect. Interchange the phase sequence.</li> <li>2. The sequence input wires for forward/reverse run may not be connected to the specified terminals. Connect the wires as follows: Forward run: Short-circuit terminals RUN - RY0 Reverse run: Short-circuit terminals PSI1 - RY0 (When input terminal function setting is C03-0=1 (default value))</li> </ol>
Motor runs but the speed does not vary	<ol style="list-style-type: none"> <li>1. The load may be too heavy. Reduce the load.</li> <li>2. The frequency setting signal level may be too low. Check the signal level and circuit.</li> </ol>
Motor acceleration/ deceleration is not smooth	<ol style="list-style-type: none"> <li>1. The motor acceleration/deceleration time setting (A01-0, 1) may be too low. Increase the acceleration/deceleration time.</li> </ol>
Motor speed varies during constant speed operation	<ol style="list-style-type: none"> <li>1. The load may be fluctuating excessively or the load is too heavy. Reduce the load or fluctuation.</li> <li>2. The inverter-motor ratings may not match the load. Select an inverter-motor set that matches the load.</li> </ol>
Motor speed is too high or low	<ol style="list-style-type: none"> <li>1. The number of poles or voltage may be incorrect. Check the motor specifications.</li> <li>2. The maximum frequency (speed) or base frequency [B00-4, 5 (B01-4, 5)] may be incorrect.</li> <li>3. The motor terminal voltage may be low. Use a thicker output cable.</li> </ol>

## Appendix 1 Type Description System

### ■ Standard specifications

#### ■ 200V Series up to U2KN037K0

Item		Specifications													
System		200V Series (NxxKx)													
Type (VAT2000-U2KN_)		00K4	00K7	01P5	02P2	04K0	05K5	07K5	11K0	15K0	18K5	22K0	30K0	37K0	
Inverter rating	Constant torque (Note 8)	Rated capacity [kVA] (Note 1)	1.0	1.7	2.7	3.8	5.5	8.3	11.4	15.9	21.1	26.3	31.8	41.0	50.0
		Max. continuous rated current [A] (Note 2)	3.0	5.0	8.0	11	16	24	33	46	61	76	92	118	144
		Max. applicable motor [kW] (Note 3)	0.4	0.75	1.5	2.2	3.7	5.5	7.5	11	15	18.5	22	30	37
		Max. Loses (W)	49	62	84	117	153	215	301	420	506	708	757	1192	1491
		Working ambient temperature	-10 to 50°C												
	Carrier frequency (Note 5)	Standard 10kHz, variable between 1 and 15kHz											Standard 4kHz, variable between 1 and 15kHz		
	Overload current rating	150% for 1min.													
	Variable torque	Rated capacity [kVA] (Note 1)	1.2	2.1	3.0	5.1	7.6	10.0	14.5	19.3	24.2	29.7	37.4	45.0	55.0
		Max. continuous rated current [A] (Note 2)	5.0	8.0	11	16	22	33	42	61	76	86	108	134	161
		Max. applicable motor [kW] (Note 3)	0.75	1.5	2.2	3.7	5.5	7.5	11	15	18.5	22	30	37	45
Max. Loses (W)		62	84	117	153	215	301	420	506	708	757	1032	1341	1657	
Working ambient temperature		-10 to 40°C (Note 4)							-10 to 50°C						
Carrier frequency (Note 5)		Standard 4kHz, variable between 1 and 15kHz													
Overload current rating		120% for 1min.													
Power supply	Rated input AC voltage: rated input frequency	200~230V ± 10% 50/60Hz ± 5%				200~220V ± 10%/50Hz±5% 200~230V ±10%/60Hz±5%									
	Rated output voltage	200~230V (Max.) (Note 7)													
Output (Note 9)	Output frequency	0.1~440Hz													
	Construction	Structure	Wall-mounted												
Enclosure		IP20									IP00				
Approx. weight (kg)		3.5					6		13		26		55		60
Cooling method		Self-cooling		Forced air cooling											
Paint color	Munsell N4.0														
Working environment	Indoors, Relative humidity: 95%RH or below (no dew condensation), Altitude: 1000m or less, Vibration: 3.0m/s <sup>2</sup> or less Freedom from corrosive or explosive gases, steam, dust, oil mist or cotton lint.														

## Appendix

### ■ 400V Series VAT2000 up to U2KX45K0

Item		Specifications															
System		400V Series (XxxKx)															
Type (VAT2000-U2KX_)		00K4	00K7	01P5	02P2	04K0	05K5	07K5	11K0	15K0	18K5	22K0	30K0	37K0	45K0		
Inverter rating	Constant torque (Note 8)	Rated capacity [kVA] (Note 1)	1.0	1.7	2.5	3.8	5.9	9.0	11.7	15.9	21.4	25.6	30.4	41.5	50.0	60.0	
		Max. continuous rated current [A] (Note 2)	1.5	2.5	3.6	5.5	8.6	13	17	23	31	37	44	60	72	87	
		Max. applicable motor [kW] (Note 3)	0.4	0.75	1.5	2.2	3.7	5.5	7.5	11	15	18.5	22	30	37	45	
		Max. Loses (W)	63	83	111	129	175	275	345	369	481	550	675	876	945	1175	
		Working ambient temperature	-10 to 50°C														
		Carrier frequency (Note 5)	Standard 10kHz, variable between 1 and 15kHz												Standard 4kHz variable between 1 and 15kHz		
		Overload current rating	150% for 1min.														
	Variable torque	Rated capacity [kVA] (Note 1)	1.7	2.5	3.8	5.9	9.0	11.7	15.9	21.4	25.6	30.4	41.5	50.5	55.0	75.0	
		Max. continuous rated current [A] (Note 2)	2.5	3.6	5.5	8.6	13	17	23	31	37	44	60	73	84	108	
		Max. applicable motor [kW] (Note 3)	0.75	1.5	2.2	3.7	5.5	7.5	11	15	18.5	22	30	37	45	55	
		Max. Loses (W)	83	111	129	175	275	345	369	481	550	675	876	1080	1104	1437	
		Working ambient temperature	-10 to 50°C														
		Carrier frequency (Note 5)	Standard 4kHz, variable between 1 and 15kHz														
		Overload current rating	120% for 1min.														
Power supply	Rated input AC voltage: rated input frequency (Note 6)	380~460V ± 10%, 50/60Hz±5% 480V - 10%, +5% 50/60Hz±5%															
Output (Note 9)	Rated output voltage	380~480V (Max.) (Note 7)															
	Output frequency	0.1~440Hz															
Const- struction	Structure	Wall-mounted															
	Enclosure	IP20										IP00					
	Approx. weight (kg)	3.5					6			13			26		50		50
	Cooling method	Self-cooling			Forced air cooling												
	Paint color	Munsell N4.0															
Working environment		Indoors, Relative humidity: 95%RH or below (no dew condensation), Altitude: 1000m or less, Vibration: 3.0m/s <sup>2</sup> or less Freedom from corrosive or explosive gases, steam, dust, oil mist or cotton lint.															

**Appendix**

■ **400V Series VAT2000 from U2KX55K0S to U2KX315KS**

Item		Specifications														
System		400V Series (XxxKx)														
Type (VAT2000-U2KX_)		55K0	75K0	90K0	110K	132K	160K	200K	250K	315K						
Inverter rating	Constant torque (Note 8)	Rated capacity [kVA] (Note 1)	75	100	120	150	170	220	300	360	400					
		Max. continuous rated current [A] (Note 2)	108	145	173	214	245	321	428	519	590					
		Max. applicable motor [kW] (Note 3)	55	75	90	110	132	160	200	250	315					
		Max. Loses (W)	1558	2020	2509	3343	3906	4915	6520	7848	9026					
		Working ambient temperature	-10 to 50°C													
		Carrier frequency (Note 5)	Monosound standard 4kHz, variable between 1 and 8kHz													
		Overload current rating	150% for 1min.													
	Variable torque	Rated capacity [kVA] (Note 1)	100	120	140	170	200	250	330	400	460					
		Max. continuous rated current [A] (Note 2)	147	179	208	242	293	365	479	581	661					
		Max. applicable motor [kW] (Note 3)	75	90	110	132	160	200	250	315	370					
		Max. Loses (W)	2091	2473	2998	3758	4637	5566	7266	8745	10061					
		Working ambient temperature	-10 to 50°C													
		Carrier frequency (Note 5)	Monosound standard 4kHz, variable between 1 and 8kHz													
		Overload current rating	112% for 1min.													
Power supply	Rated input AC voltage: rated input frequency (Note 6)	380~460V ± 10%, 50/60Hz±5%														
Output (Note 9)	Rated output voltage	380~460V (Max.) (Note 7)														
	Output frequency	0.1~440Hz														
Const- ruction	Structure	Wall-mounted														
	Enclosure	IP00														
	Approx. weight (kg)	55	60	65	70	90	100	210	300							
	Cooling method	Forced air cooling														
	Paint color	Munsell 5Y7/1.0														
Working environment		Indoors, Relative humidity: 95%RH or below (no dew condensation), Altitude: 1000m or less, Vibration: 4.9m/s <sup>2</sup> or less Freedom from corrosive or explosive gases, steam, dust, oil mist or cotton lint.														

- Note 1)** The output voltage indicates the output capacity [kVA] at 200V for the 200V series, and 400V for the 400V series.
- Note 2)** Indicates the total effective value including the higher harmonics.
- Note 3)** Indicates the case for the standard 4-pole squirrel cage motor.
- Note 4)** When 40°C is exceeded, derate the output current by 2% for each 1°C. (Refer to Fig. 1-1.)

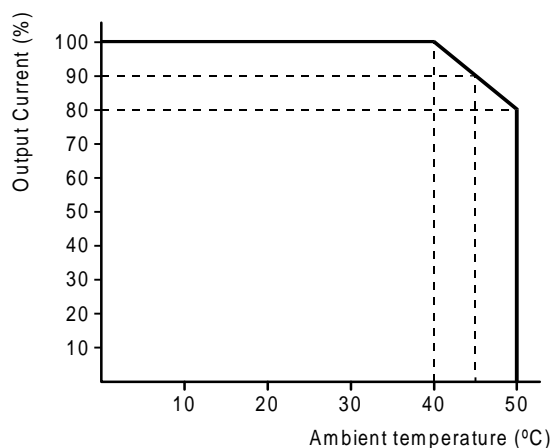

Fig. 1-1 Derating according to ambient temperature

**Note 5)** Drives up to U2KN22K0S, and U2KX30K0S

In Constant Torque, drives allow carrier frequency up to 10kHz. Derate 7% current per kHz above that frequency.

In Variable Torque, normal carrier frequency is 4kHz. Above 4kHz, derate current in ratio by (Variable torque rating-Constant Torque rating)/6 per 1kHz, above 4kHz. Check fig. 1-2.

Drives from U2KN22K0S to U2KN37K0S or from U2KX30K0S to U2KX45K0S

Normal carrier frequency is 4kHz in both CT or VT rating. VAT2000 should be derated in a 7% current per kHz above 4kHz as shown in fig 1-3

Drives U2KX55K0S or larger

Normal carrier frequency is 4kHz in both CT or VT rating. VAT2000 should be derated in a 5% current per kHz above 4kHz as shown in fig 1-4

If the heatsink temperature 70°C is exceeded and the output current exceeds 90%, the carrier frequency will automatically change to 4kHz.

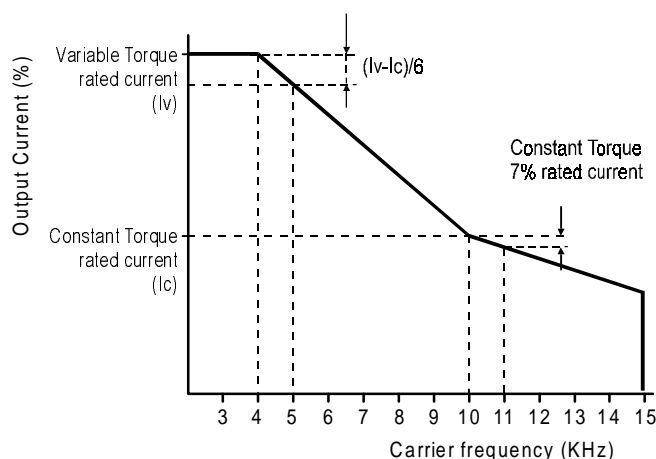

Fig. 1-2 Derating according to carrier frequency for drives up to N22K0 and up to X30K0

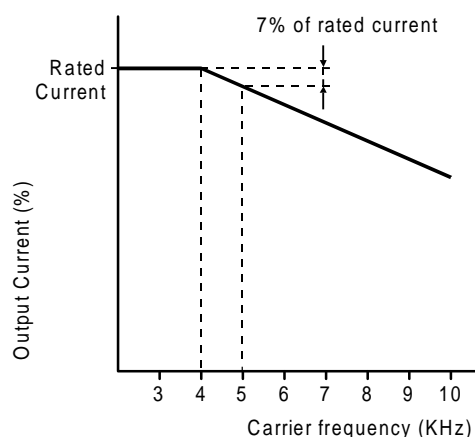
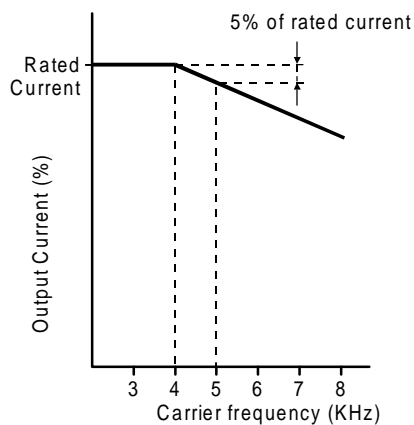

Fig. 1-3 Derating according to carrier frequency for drives larger than N22K0 or from X30K0 to X45K0

**Note)** When changing the carrier frequency, take care to the motor's temperature rise



**Fig. 1-4 Derating according to carrier frequency for drives larger than U2KX45K0S**

**Note)** When changing the carrier frequency, take care to the motor's temperature rise

**Note 6)** This inverter is subject to the EC Low Voltage Directives. The rated input voltage will be 380 to 415V to comply to the EC Low Voltage Directives.

**Note 7)** An output voltage exceeding the input voltage cannot be attained.

**Note 8)** When using the speed sensor-less vector control, the vector control with speed sensor, or the PM motor control, select the applicable motor from the max. continuous rated current [A] of the constant torque.

## Appendix

### ■ Control specifications table

		V/f control (constant torque)	V/f control (variable torque)	Speed sensor-less vector control	Vector control with speed sensor (Note 1)	PM motor control (Note 2)
Frequency control	Control method	All digital control Sine wave approximation PWM				
	Transfer frequency	Mono-sound mode : 1 to 15KHz (1KHz increments) Soft sound mode : Average frequency 2.1 to 5KHz Frequency modulation method (3 tone modulation, 4 tone modulation)				
	Output frequency resolution	0.01Hz				
	Frequency setting resolution	0.01Hz (digital) 0.025% (analog) In respect to maximum frequency				
	Frequency accuracy	±0.01% (digital) at 25±10°C ±0.1% (analog) at 25±10°C				
Control specifications	Voltage/frequency characteristics	Select randomly from constant torque, constant output and reduction torque 3 to 440Hz range.	Select randomly from constant torque and constant output 150 to 7200min <sup>-1</sup> (120Hz) range.			
	Torque boost	Manual/automatic selective	—			
	Max. torque boost	Max. torque for applicable motor is output when used with automatic tuning.	—			
	Automatic tuning	Automatic measurement of motor constants Automatic measurement of various parameters (Measurement time approx. 2 minutes)				—
	Starting frequency	Set between 0.1 and 60.0Hz		—		
	Starting torque	200% or more (Time to reach using AEG standard motor at 150%A: approx. 3 seconds)		—		
	Acceleration/ deceleration time	0.01 to 60000sec Acceleration/deceleration time × 2, jogging dedicated × 1, program cushion × 8				
	Acceleration/ deceleration mode	Linear/S-character selective				
Operation method	3 modes selective <ul style="list-style-type: none"> <li>• Forward run/reverse run</li> <li>• Run stop/forward run reverse run</li> <li>• Forward run pulse/reverse run pulse/stop</li> </ul>					

**(Note 1)** The IM speed detection option PCB is required.

**(Note 2)** This is for the standard PM motor. The PM speed detection option PCB is required.

**Appendix**

		V/f control (constant torque)	V/f control (variable torque)	Speed sensor- less vector control	Vector control with speed sensor	PM motor control
Control specifications	Stop method	Deceleration stop in respect to run, emergency stop and inching, coast to stop selective				
	DC braking	Braking start frequency, randomly set between 0.1 and 60.0Hz Braking voltage, randomly set between 0.1 and 20.0% Braking time, randomly set between 0.0 and 20.0 seconds				
	Output frequency	0 to 440Hz		0 to 120Hz		
	ASR	—	Control range	1 : 100	1 : 1000	1 : 100
			Constant output range	Up to 1 : 2	Up to 1 : 4	Up to 1 : 1.2
			Control accuracy (At Fmax ≥ 50Hz)	±0.5%	±0.01%	±0.01%
			Control response	5Hz	30Hz	—
Setting	Multi-step frequency setting	8 steps Acceleration/deceleration time as changeable 5-bit non-encode mode		—		
	Ratio interlock setting	During remote setting mode $y = Ax + B + C$ y: Operation results x: Operation input A: 0.000 to ±10.000 B: 0.00 to ±440Hz C: Auxiliary input With output upper/lower limit		During remote setting mode $y = Ax + B + C$ y: Operation results x: Operation input A: 0.000 to ±10.000 B: 0 to ±7200min <sup>-1</sup> (120Hz) C: Auxiliary input With output upper/lower limit		
	Frequency jump	Three places can be set Width can be varied between 0.0 and 10Hz				
	Slip compensation	Operation/non selective Slip compensation gain: 0.0 to 20.0		—		
	Automatic run function	10-step automatic run function Synchronous/asynchronous selective				
	Others	PID control Pick-up Automatic start Restart after instantaneous power failure  Reverse run prevention  Traverse pattern		Pick-up Automatic start Restart after instantaneous power failure Reverse run prevention Traverse pattern		Automatic start Restart after instantaneous power failure  Reverse run prevention  Traverse pattern
Control input/output	Standard panel	Display: 7-segment LED × 5 digits and sign    Status/unit display LED: 8 points Operation: Operate with knob and set keys Local/remote changeover operation, forward run/reverse run direct run operation, all parameter reference/change, others Unit installation possible (extension cable max. 3m)				
	Sequence input	Fixed: 3 points    Programmable: 5 points    Sink/source changeable				
	Sequence output	Relay 1c contact: 1 point (fault)    Relay 1a contact: 1 point (programmable) Open collector: 3 points (programmable) The programmable details can be changed between speed detection, pre-charging complete, reverse run, speed reached, direction operation, current reached, speed reached, acceleration, deceleration and fault code				
	Frequency setting	FSV: 0 to 10V/0 to 5V/1 to 5V FSI: 4 to 20mA/0 to 20mA AUX: 0 to ±10V/0 to ±5V/1 to 5V (Used for the ratio interlock, operation or PID feedback)				

## Appendix

		V/f control (constant torque)	V/f control (variable torque)	Speed sensor- less vector control	Vector control with speed sensor	PM motor control
Control	Meter output	0 to 10VDC, 1mA (programmable) : 2 points Change between output frequency, output voltage, output current, DC voltage, etc.				
	Preventive	Overcurrent limit (drive regeneration limit variable), overvoltage limit, overload warning contact				
Protection	Shut-off	Overcurrent, overvoltage, undervoltage, IGBT fault, overload, temperature rise, ground fault, other self-diagnosis				
	Fault history	Past four faults are saved. Saved details: Primary cause, secondary cause, output current and output frequency before shut-off.				
	Overload withstand level	150% for 1 minute, 170% for 2.5 seconds (50% of left values for 3Hz and less) Inverse time characteristics (variable torque) 120% for 1 minute, 125% for 1 seconds (75% of left value for 3Hz and less) Inverse time characteristics (variable torque)				
	Retry	Randomly set between 0 and 10 times				

## Appendix 2 Outline Dimension Drawings

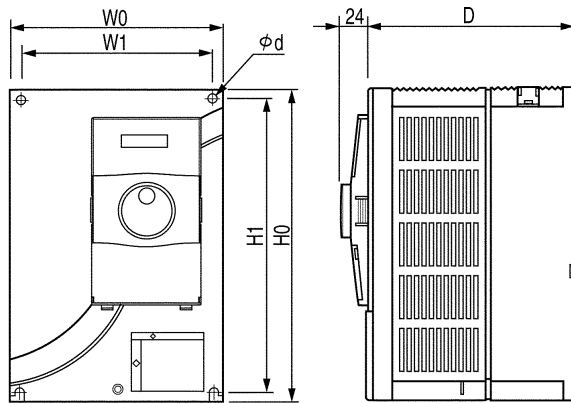

Fig.1

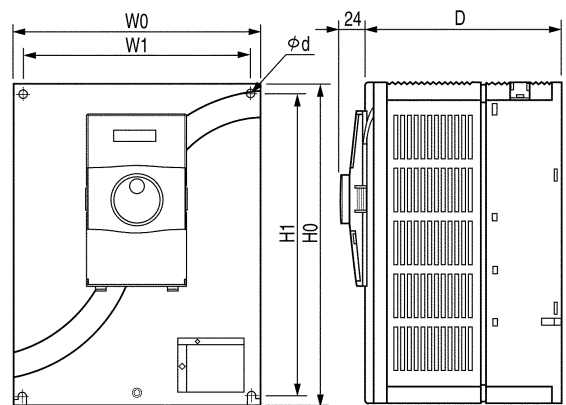

Fig.2

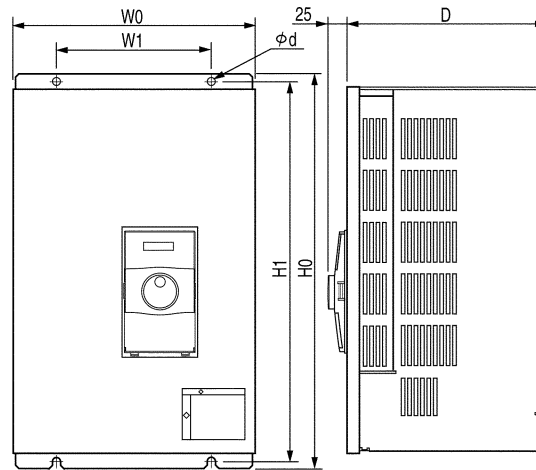

Fig.3

Type Series		Dimensions (mm)						Fig.
200V	400V	W0	W1	H0	H1	D	ød	
N00K4 N00K7 N01K5 N02K2 N04K0	X00K4 X00K7 X01K5 X02K2 X04K0	170	155	243	228	162	6	Fig. 1
N05K5 N07K5	X05K5 X07K5	216	201	275	260	169	7	
N11K0 N15K0	X11K0 X15K0 X18K5	265	245	360	340	228		
N18K5 N22K0	X22K0 X30K0	310	200	500	480	253	10	Fig. 3
N30K0 N37K0	X37K0 X45K0	342	200	590	570	307		
	X55K0 X75K0	420	300	690	666	309		
	X90K0 X110K	480	400	740	714	352		
	X132K X160K	488	320	980	956	370	13	
	X200K	680	500	1100	1070	379	15	
	X250K X315K	870	600	1300	1270			

## Appendix 3 Fault Codes

Code	Display	Fault	Description	Retry
0	---	No fault	No fault recorded.	×
1	Err. (EmS)	Emergency stop	Indicates that sequence signal EMS has been input in C00-4 = 2 (fault output at emergency stop) mode.	×
2	Pn - n (PM-n)	Power Module	Power module fault n: sub-code 1: during stop 2: during operation at the set speed 3: during acceleration 4: during deceleration 5: during braking 6: during ACR 7: during pre-extension 9: during automatic tuning	○
3	OC - n (OC-n)	Over current	The output has risen to or beyond 300%. n: sub-code 1: during stop 2: during operation at the set speed 3: during acceleration 4: during deceleration 5: during braking 6: during ACR 7: during pre-extension 9: during automatic tuning	○
4	OV - n (OV-n)	Over voltage	The DC voltage has risen to or beyond the preset level. (Vdc ≥ 800 or 400V) n: sub-code 1: during stop 2: during operation at the set speed 3: during acceleration 4: during deceleration 5: during braking 6: during ACR 7: during pre-extension 9: during automatic tuning	○
5	UV - n (UV-n)	Under voltage	While the drive is running, the DC voltage has lowered to or beyond the preset level (65% of the rating). n: sub-code 1: during stop 2: during operation at the set speed 3: during acceleration 4: during deceleration 5: during braking 6: during ACR 7: during pre-extension 9: during automatic tuning At C08-0 = 2, 3 (automatic start), only the symbol displays, so the FLT LED and terminal block FA, FB and FC contacts will not operate. EC0 to 3 will operate.	×
6	Not defined			
7	UoH.	Overheat	The heatsink temperature has risen to or beyond 95°C.	○
8	OP	Overspeed	Indicates that the motor speed exceeded the overspeed setting value (C24-0).	×
9	Not defined			
A	Att - n (ATT-n)	Automatic tuning abnormal completion	This indicates that the automatic tuning did not complete normally. n: Automatic tuning step No. (when interrupted) (1) ACR simple setting (2) Single-phase AC measurement (3) ACR adjustment (9) Excitation inductance measurement (A) Secondary resistance measurement (B) Max. torque boost adjustment (C) Excitation inductance fluctuation table adjustment	×
B	OL - n (OL-n)	Overload	Indicate that the output current exceeded the thermal operation time having inverse time characteristics. The standard characteristics are 150% for one minute in respect to the motor rated current. At 155% or more in respect to the inverter rated current, this will be 170% for 2.5 seconds. n: Sub-code 1: Drive output overload	○
C	Grd. (GRD. n)	Ground	The Drive has sensed a grounded conditions on the output. n: sub-code 1: during stop 2: during operation at the set speed 3: during acceleration 4: during deceleration 5: during braking 6: during ACR 7: during pre-extension 9: during automatic tuning	○

## Appendix

	Display	Fault	Description	Retry
D	IO - n (IO-n)	I/O Error	<p>There has been an error in communications through the I/O port.</p> <p>n: sub-code</p> <p>1: Gate Shutdown Circuit error. A feedback signal has disagreed to a Gate Shutdown command.</p> <p>2: A/D Converter error. The A/D Converter has been jammed.</p> <p>3: Current Detector Offset. The offset of the Current Detector has increased to or beyond 0.5V.</p> <p>4: Retry time out. Indicates that the operation was not successful within the No. of retries set in C21-0.</p> <p>E: Thermistor fault</p> <p>F: Speed detection fault</p>	×
E	CPU. n (CPU-n)	CPU Error	<p>There has been an error while the CPU, RAM or ROM is in the self-diagnosis mode at power-up.</p> <p>n: sub-code</p> <p>1: Watch-dog error, indicating that the CPU has been jammed. This fault may appear during at-speed operation.</p> <p>2: CPU calculation error.</p> <p>3: CPU RAM error.</p> <p>4: External RAM error.</p> <p>6: E<sup>2</sup>PROM check-sum error.</p> <p>7: E<sup>2</sup>PROM read error.</p> <p>8: E<sup>2</sup>PROM write error. This error is only displayed, and the gate will not shut down and FLT will not be output.</p> <p>9: Illegal combination of software version and CPU.</p>	×
F	dEt. (dEr)	E <sup>2</sup> PROM Data Error	<p>Indicates that there is an error in the various data stored in the E<sup>2</sup>PROM. For details, enter the monitor mode: D20-2, and correct the data.</p> <p><b>Caution)</b> If this appears when starting up, the details will not be stored internally. Thus, after starting up normally, these details cannot be read with the fault history (D20-0).</p>	×

## Appendix 4 7-segment LED Display

### (1) Numeric

Display	0	1	2	3	4	5	6	7	8	9
Numerics	0	1	2	3	4	5	6	7	8	9

### (2) Alphabet

Display	A	b	C	d	E	F	G	H	I	J
Alphabet	A	B (b)	C	D (d)	E	F	G	H	I	J

Display	L	M	N	O	P	Q	R	S	T	U
Alphabet	L	M (m)	N (n)	O	P	Q (q)	R (r)	S	T (t)	U

Display	V	Y	-	[ ]
Alphabet	V (v)	Y	-	(Brackets)

### (3) Message

L0C	LOC	LOCK	L4E	Lst	LIST
rUn	rUn	RUN	trC	trC	TRACE
REY	rty	RETRY	dErr	d.Err	Data ERROR
Err	Err	ERROR	dEnd	d.End	Data END
			dCHG	d.CHG	Data CHANGE

Appendix

---

Function	<Remarks>	Function	<Remarks>