



The SPECOM network analyser is the best tool to optimise and visualise the exploitation of an electrical network.

For more information, please contact:  
MAJESTIC GLOBAL LTD. [www.mgl.hk](http://www.mgl.hk)

## Content

- E.2** Description
- E.3** Specom C - Technical data
- E.4** Specom M - Technical data
- E.5** Data communication
- E.5** Converter RS 485/232
- E.5** Specom L - Exploitation software
- E.5** Ordering codes
- E.6** Current transformers
- E.8** Connection diagrams
- E.9** Overall dimensions



SPECOM M

SPECOM C

## Description

To optimise the operation of electrical networks, following tasks must be done simultaneously:

- accuracy of controlling and measuring
- efficiency of preventive monitoring
- speed in malfunction detection and analysis
- optimisation of utilisation ranges

The ability to achieve those performances is subject to the possibility to analyse and master the main parameters of the electrical network.

In order to reply even more efficiently to the requirements of the market, our range of network analysers is today constituted of:

- a range of modular products for DIN rail mounting: SPECOM M
- a range of products for panel mounting at the 144 x 144 mm format: SPECOM C

It is also important to note the evolution possibilities of the SPECOM C range. A large range of interchangeable modules allows a permanent evolution of the products capabilities at the lowest modification costs.

SPECOM ensures to the electrical installation 'Management' and 'Communication'.

## Communication

SPECOM C et SPECOM M measure and display continuously three different parameters of the electrical network. The instantaneous, average, maximum and minimum values can be consulted locally by means of a four keys keyboard on a LED screen (SPECOM C) or LCD screen (SPECOM M). The combination of SPECOM C30, SPECOM M10, SPECOM M30, SPECOM M40 with the software SPECOM L allows the centralisation and exploitation of all the measurements.

## Management

SPECOM is a management unit that ensures simultaneously:

- the true RMS measurement of all electrical parameters (voltage, current, power factor as well as the frequency on the network).
- the calculation of active and reactive power and energy per phase and global.
- the calculation of the harmonics rate per phase (current and voltage). All the harmonics up to rank 15 are considered in the calculation.
- the storage in memory of maximum values of intensity, power, active and reactive energy per phase and global.
- economy and service improvement by incident prevention, consumption adaptation to tariff system and accurate consumption cost allocation.

## Operation

### Measurements

For each of the three phases, the SPECOM C and SPECOM M units measure the true RMS values of:

- current on 5 amps isolated input. This requires external 5 amps current transformers. The accuracy of the measurement is directly linked to the current transformer's accuracy. The ratio is programmable from 1 to 10000.
- voltage phase to neutral or phase to phase. The connection of the neutral is facultative. The ratio is programmable from 1 to 100000.
- frequency on phase 1.
- power factor.

From these measurements, SPECOM calculates the active and reactive energy per phase and global. All those parameters are available in instantaneous values each second and on a mobile average period programmable from 1 to 60 minutes.

- ① Green LED display
- ② Signalling unit
- ③ Keys
- ④ Compartment for options
- ⑤ Fixation system
- ⑥ Auxiliary wiring
- ⑦ Connection diagram
- ⑧ List of programmable parameters

## SPECOM C

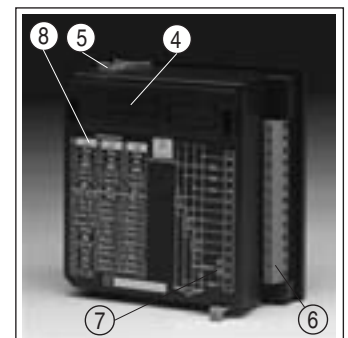
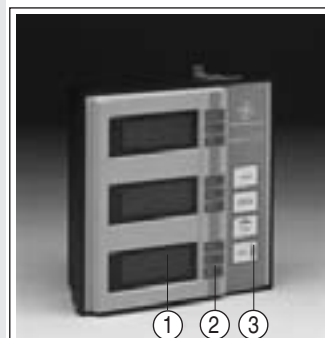



## SPECOM C

### Aspect

- normalised DIN 43700 enclosure (144 x 144 x 58 mm)
- slider fixation system
- connection on the rear on one terminal block
- built-in relay protection degree: IP41
- protection degree at the terminal location: IP20



### Power supply

230 or 400V CA 50/60Hz  
On request, other possibilities are available

### Power consumption 3VA

### Local interface

- green LED display
- permanent display of three parameters
- four keys keyboard
- automatic display of the metering units

### Display

Minimum, average and maximum values for voltages, currents, powers and power factor.

### Maximum values to apply

- connection between phase and neutral: 500V AC RMS
- connection between phases: 866V AC RMS
- maximum current: 6A RMS

### Insulation

- power supply and measurement unit: 5kV
- measurement inputs: 2.5kV
- alarm contact, data communication and earth: 1kV

### Pulse outputs / Alarm outputs (Specom C40)

- maximum admissible current: 120mA
- maximum peak voltage: 300V
- programmable weight of pulse
- programmable width of pulse

### Environment

- operational temperature: 0°C up to +50°C
- storage temperature: -20°C up to +80°C

### Standards IEC 664, VDE 0110, UL 94, IEC 801, IEC 348 and IEC 571.1

### Accuracy

% of the measured parameter in case of ambient temperatures between +5°C and +45°C

Parameter	Accuracy	Resolution
Single voltage	± 0.5%	± 2 digits
Compound voltage	± 0.5%	± 2 digits
Current	± 0.5%	± 2 digits
Active power	± 1%	± 2 digits
Reactive power	± 1%	± 2 digits
Active energy	± 1%	± 2 digits
Reactive energy	± 1%	± 2 digits
Power factor	± 1%	± 2 digits
Frequency	± 0.1%	± 2 digits
Clock		± 2 digits

### Pulse output/Alarm output

The SPECOM C40 unit gives possibility to configure two relay outputs either as pulse outputs or as alarm outputs. Each pulse output is assigned to the two active and reactive energy counters. The alarm outputs are programmable and can be assigned to one of the numerous parameters measured by the unit.

Any overshoot of alarm thresholds will induce a tripping of the alarm relay. The reset of the alarm relay is done locally.

### Set up/consultation

The SPECOM C network analysers are locally programmable. The parameters to configure are:

- voltage input
- nominal primary current
- average calculation period
- alarm threshold (SPECOM C40)
- width and weight of each pulse (SPECOM C40)
- speed and parity (SPECOM C30)

### Functions and measurements

SPECOM	C10	C20	C30	C40
<b>Local display</b>				
3 phase-to-neutral voltage	•	•	•	•
3 phase-to-phase voltage	•	•	•	•
3 current	•	•	•	•
3 active power per phase	•	•	•	•
3 reactive inductive power per phase	•	•	•	•
3 reactive capacitive power per phase	•	•	•	•
3 power factor per phase	•	•	•	•
phase-to-neutral average voltage	•	•	•	•
three phase average current	•	•	•	•
global active power	•	•	•	•
global reactive inductive power	•	•	•	•
global reactive capacitive power	•	•	•	•
global power factor	•	•	•	•
frequency	•	•	•	•
global apparent power	•	•	•	•
phase-to-phase average voltage	•	•	•	•
harmonics rate calculation - current/phase (%THD)	•	•	•	•
harmonics rate calculation - voltage/phase (%THD)	•	•	•	•
<b>Energy measurement</b>				
date/time		•	•	•
active energy (tariff 1)		•	•	•
reactive inductive energy (tariff 1)		•	•	•
reactive capacitive energy (tariff 1)		•	•	•
maximum (kW, kVA, AIII)	•	•	•	•
<b>Sorties</b>				
2 alarm outputs or 2 pulse outputs				•
<b>Communication</b>				
RS 485 output			•	

### Extension modules

The SPECOM C network analysers (excepted SPECOM C10) are originally equipped with one of the here below modules. Those interchangeable modules allow a permanent evolution of the product according to the customer's requirements.

- **module ER:** adds to the standard measurements, the active capacitive and reactive inductive energies as well as the clock functions and maximeter (kW, kVA, AIII).
- **module ER-485:** offers the possibilities of the module ER and an RS 485 output.
- **module ERC-2:** offers the possibilities of the module ER and two programmable relay outputs. Those programmable relay outputs can be assigned to pulse counters or alarm outputs.

### Remark

Others modules (output 4-20mA ...) are available on request.



## SPECOM M

### Aspect

- modular box: 140 x 70 x 110 (8 modules according to DIN 43880)
- fixation on DIN 46277 rail (EN 50022)
- connection on terminal block
- built-in relay protection degree: IP41
- protection degree at the terminal location: IP20



### Power supply

230 CA 50/60Hz

### Power consumption

6 VA

### Local interface

- LCD display
- permanent display of three parameters
- four keys keyboard
- automatic display of the metering units

### Display

Minimum, average and maximum values for voltages, current, powers and power factor.

### Maximal values to apply

- connection between phase and neutral: 500V AC RMS
- connection between phases: 866V AC RMS
- maximum current 6Amps RMS

### Insulation

- power supply and measurement units: 5kV
- measurement inputs: 2.5kV
- alarm contact, data communication, earth: 1kV

### Pulse outputs / Alarm outputs (Specom M40)

- maximum admissible current: 120mA
- maximum peak voltage: 300V
- programmable weight of pulse
- programmable width of pulse

### Environment

- operational temperature: 0°C up to +50°C
- storage temperature: -20°C up to +80°C

### Standards

IEC 664, VDE 0110, UL 94, IEC 801\*, IEC 348\* and IEC 571.1\*  
\*excepted SPECOM M10

### Accuracy

% of the measured parameter in case of ambient temperatures between +5°C and 45°C

Single voltage	± 0.5%	± 2 digits
Compound voltage	± 0.5%	± 2 digits
Current	± 0.5%	± 2 digits
Active power	± 1%	± 2 digits
Reactive power	± 1%	± 2 digits
Active energy	± 1%	± 2 digits
Reactive energy	± 1%	± 2 digits
Power factor	± 1%	± 2 digits
Frequency	± 0.1%	± 2 digits
Clock		± 2 digits

### Pulse output/alarm output

The SPECOM M40 gives the possibility to configure two relay outputs as pulse outputs or as alarm outputs. Each pulse output is assigned to the two active and reactive energy counters. The alarm outputs are programmable and can be assigned to one of the numerous parameters measured by the unit.

Any overshoot of alarm thresholds will induce a tripping of the alarm relay. The reset of the alarm relay is done locally.

### Set up/consultation

The SPECOM M network analysers (excepted SPECOM M10) are locally and remotely programmable.

The parameters to configure are:

- voltage input
- nominal primary current
- average calculation period
- alarm threshold (SPECOM M40)
- width and weight of each pulse (SPECOM M40)
- speed and parity (SPECOM M10, SPECOM M30, SPECOM M40)

### Functions and measurements

SPECOM	M10	M20	M30	M40
<b>Local display</b>				
3 phase-to-neutral voltage	•	•	•	•
3 phase-to phase voltage	•	•	•	•
3 current	•	•	•	•
3 active power per phase	•	•	•	•
3 reactive inductive power per phase	•	•	•	•
3 reactive capacitive power per phase	•	•	•	•
3 power-factor per phase	•	•	•	•
phase-to-neutral average voltage	•	•	•	•
three phase average current	•	•	•	•
global active power	•	•	•	•
global reactive inductive power	•	•	•	•
global reactive capacitive power	•	•	•	•
global power factor	•	•	•	•
frequency	•	•	•	•
global apparent power	•	•	•	•
phase-to-phase average voltage	•	•	•	•
harmonics rate calculation current/phase (%THD)	•	•	•	•
harmonics rate calculation voltage/phase (%THD)	•	•	•	•
<b>Energy measurement</b>				
date/time	•	•	•	•
active energy (tariff 1)	•	•	•	•
reactive inductive energy (tariff 1)	•	•	•	•
reactive capacitive energy (tariff 1)	•	•	•	•
maximum demand (kW, kVA, AIII)	•	•	•	•
active energy (tariff 2 & 3)	•	•	•	•
reactive inductive energy (tariff 2 & 3)	•	•	•	•
reactive capacitive energy (tariff 2 & 3)	•	•	•	•
generated active energy (tariff 1, 2 & 3)	•	•	•	•
generated reactive inductive energy (tariff 1, 2 & 3)	•	•	•	•
generated reactive capacitive energy (tariff 1, 2 & 3)	•	•	•	•
<b>Outputs</b>				
2 alarm outputs or 2 pulse outputs				•
<b>Communication</b>				
RS 485 output	•		•	•
<b>Memory</b>				
internal memory 128K	•			



## Data communication

SPECOM C30, SPECOM M20, SPECOM M30, SPECOM M40 use the MODBUS protocol on RS 485 hardware to communicate. By means of that bus, and thanks to the SPECOM L exploitation software, it is possible to transmit the measurements and other recorded data to a PC.

Initialisation and remote programming can be done from a master computer. In order to maintain a good communication quality, the master computer can not communicate with more than 32 units connected in parallel on the communication gate. The SPECOM M20, SPECOM M30, SPECOM M40 units are equipped with two RS 485 outputs, one is dedicated to the communication with a PC and the other one is dedicated to peripherals.

The physical supports of communication are:

- RS 485 hardware support (3 wires)
- transmission speed: 2400, 4800, 9600, 19200 bauds
- MODBUS protocol
- parity: with or without

## Intelligent converter RS 485/232

### Function

The converter operates as interface between a standard RS 232 link and a RS 485 communication line.

### Characteristics

- power supply 220V AC +/- 10%
- input - serial output RS 232 (female DB9 plug)
- input - serial output RS 485 (male DB9 plug)
- mounting on DIN rail 46277 (EN 50022)
- modular box
- overall dimensions: 70 x 70 x 85 mm
- built-in relay protection degree: IP41
- protection degree at the terminal location: IP20

## Specom L exploitation software

The SPECOM L exploitation software allows the management of an electrical network. It reads at regular programmable intervals the value of the different parameters of the network. The collected parameters are synthesised on one page of screen and are also transferred to Excell files in order to be exploited later. A test of each SPECOM or peripheral can be done from SPECOM L software. It is also possible to simulate a network.

## Connection on the local network RS 485

Specom M or Specom C can be connected to a local data communication network, in association with a computer featuring a serial port and an interface adapter RS 485/RS 232

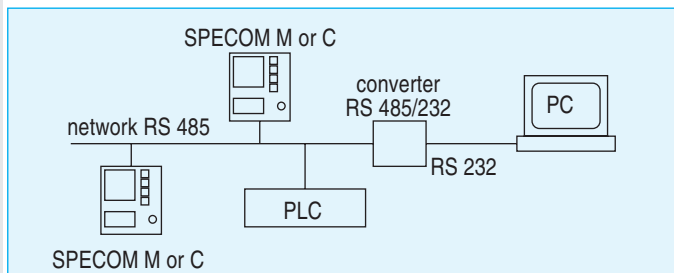

## Codes

### SPECOM C

1	769906	Specom C10
1	769907	Specom C20
1	769908	Specom C30
1	769909	Specom C40



### SPECOM M

1	769923	Specom M10
1	769920	Specom M20
1	769921	Specom M30
1	769922	Specom M40



### Modules for SPECOM C

1	769930	Module ER
1	769931	Module ER-485
1	769932	Module ERC-2

### Options

1	769940	Exploitation software SPECOM L
1	769941	Converter RS 232/485
1	769942	RS 232 cable for PC (length 1 meter)



### Current transformers with closed core



#### Panel mounting - Cable

Rail 20 x 10mm or cable diam. 20 mm				
Type	ASK 421.4	Dimensions	Weight	Code
Prim./Sec.	Power in VA	LxHxP (mm)	(kg)	
(A)	Class 0.5			
40/5	2.5	71x88.5x72	0.15	782790
50/5	2.5	71x88.5x72	0.17	782791
60/5	2.5	71x88.5x72	0.18	782792
75/5	5	71x88.5x72	0.18	782793
100/5	10	71x88.5x72	0.18	782795
150/5	10	71x88.5x72	0.18	782796

Rail 40 x 10mm or cable diam. 30 mm				
Type	TA 30	Dimensions	Weight	Code
Prim./Sec.	Power in VA	LxHxP (mm)	(kg)	
(A)	Class 0.5			
200/5	1.25	52x65x52	0.15	666378
250/5	1.25	58x66.5x58	0.15	769800
400/5	2.5	58x66.5x58	0.17	769801
500/5	3.75	58x66.5x58	0.18	769802
600/5	3.75	58x66.5x58	0.2	769803
Mounting plate on DIN rail for TA 30		58x40x7.5	0.01	769804

Rail 40 x 10mm or cable diam. 30 mm				
Type	TA 200	Dimensions	Weight	Code
Prim./Sec.	Power in VA	LxHxP (mm)	(kg)	
(A)	Class 0.5			
250/5	2.5	75x104.5x50	0.38	769805
400/5	3.75	75x104.5x50	0.4	769806
500/5	5	75x104.5x50	0.4	769807
600/5	5	75x104.5x50	0.4	769808
800/5	10	75x104.5x50	0.41	769809
1000/5	15	75x104.5x50	0.45	769810

#### Panel mounting - Rail

Rail 30 x 10mm or cable diam. 22 mm				
Type	TA 380	Dimensions	Weight	Code
Prim./Sec.	Power in VA	LxHxP (mm)	(kg)	
(A)	Class 0.5			
400/5	10	132x154.5x58	0.82	769811
500/5	10	132x154.5x58	0.8	769812
600/5	10	132x154.5x58	0.83	769813
800/5	10	132x154.5x58	0.66	769814
1000/5	15	132x154.5x58	0.72	769815
1500/5	30	132x154.5x58	0.84	769816
2000/5	40	132x154.5x58	0.82	769817

Rail 100 x 20 mm				
Type	TA 400	Dimensions	Weight	Code
Prim./Sec.	Power in VA	LxHxP (mm)	(kg)	
(A)	Class 0.5			
1000/5	10	95x187.5x59	0.76	769820
1500/5	10	95x187.5x59	0.76	769821
2000/5	10	95x187.5x59	0.76	769822

Rail 100 x 30 mm				
Type	TA 500	Dimensions	Weight	Code
Prim./Sec.	Power in VA	LxHxP (mm)	(kg)	
(A)	Class 0.5			
2000/5	10	115x202.5x63	0.82	769825
2500/5	10	115x202.5x63	0.78	769826
4000/5	10	115x202.5x63	0.9	769827

Rail 120 x 60 mm				
Type	TA 600	Dimensions	Weight	Code
Prim./Sec.	Power in VA	LxHxP (mm)	(kg)	
(A)	Class 0.5			
2500/5	20	124x193x71	1.01	769830
4000/5	35	124x193x71	1.21	769831
5000/5	40	124x193x71	1.44	769832



**Current transformers with open core**



**Opening 50 x 80 mm**

Type	TP 58	Dimensions	Weight	Code
Prim./Sec.	Power in VA	LxHxP (mm)	(kg)	
(A)	Class 0.5			
250/5	1	114x145x59	0.9	769835
400/5	1.5	114x145x59	0.9	769836
500/5	2.5	114x145x59	0.9	769837
600/5	2.5	114x145x59	0.9	769838
800/5	3	114x145x59	0.9	769839
1000/5	5	114x145x59	0.9	769840

**Opening 80 x 80 mm**

Type	TP 88	Dimensions	Weight	Code
Prim./Sec.	Power in VA	LxHxP (mm)	(kg)	
(A)	Class 0.5			
400/5	1.5	144x145x59	1	769841
500/5	2.5	144x145x59	1	769842
600/5	2.5	144x145x59	1	769843
800/5	3	144x145x59	1	769844
1000/5	5	144x145x59	1	769845

**Opening 80 x 120 mm**

Type	TP 812	Dimensions	Weight	Code
Prim./Sec.	Power in VA	LxHxP (mm)	(kg)	
(A)	Class 0.5			
800/5	3	144x185x59	1.2	769850
1000/5	5	144x185x59	1.2	769851
1250/5	7	144x185x59	1.2	769852

**Opening 80 x 160 mm**

Type	TP 816	Dimensions	Weight	Code
Prim./Sec.	Power in VA	LxHxP (mm)	(kg)	
(A)	Class 0.5			
2000/5	15	184x245x59	3.5	769855
2500/5	15	184x245x59	3.5	769856
4000/5	20	184x245x59	3.5	769857
5000/5	20	184x245x59	3.5	769858



**Series MT - Current transformer**

Scale	Accuracy	Cat. nr.	Ref. nr.	Pack.
100/5A	1	MT CT 100	666375	1
150/5A	0.5	MT CT 150	666377	1
200/5A	0.5	MT CT 200	666378	1
250/5A	0.5	MT CT 250	666379	1
300/5A	0.5	MT CT 300	666380	1
400/5A	0.5	MT CT 400	666382	1
500/5A	0.5	MT CT 500	666384	1
600/5A	0.5	MT CT 600	666386	1
800/5A	0.5	MT CT 800	666388	1
1000/5A	0.5	MT CT 1000	666376	1

Dimensional drawings on E.9



## Specom C

Three wire system without neutral (2 current transformers)

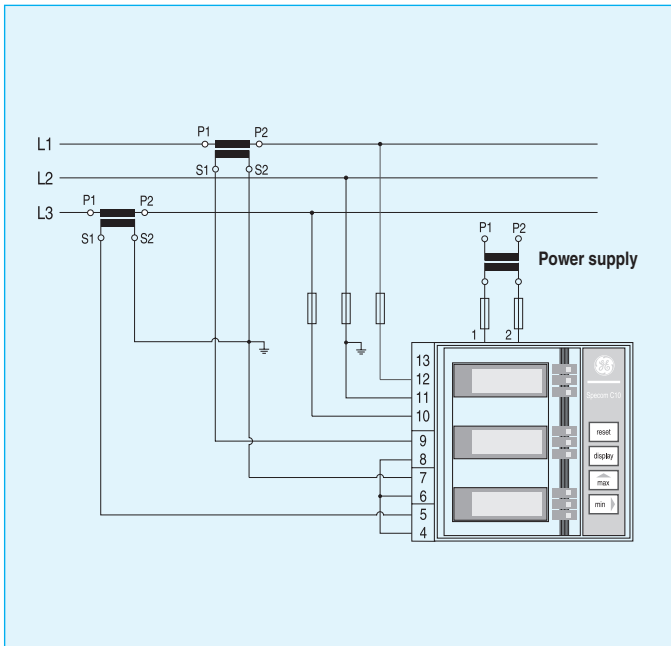

## Specom M

Three wire system without neutral (2 current transformers)

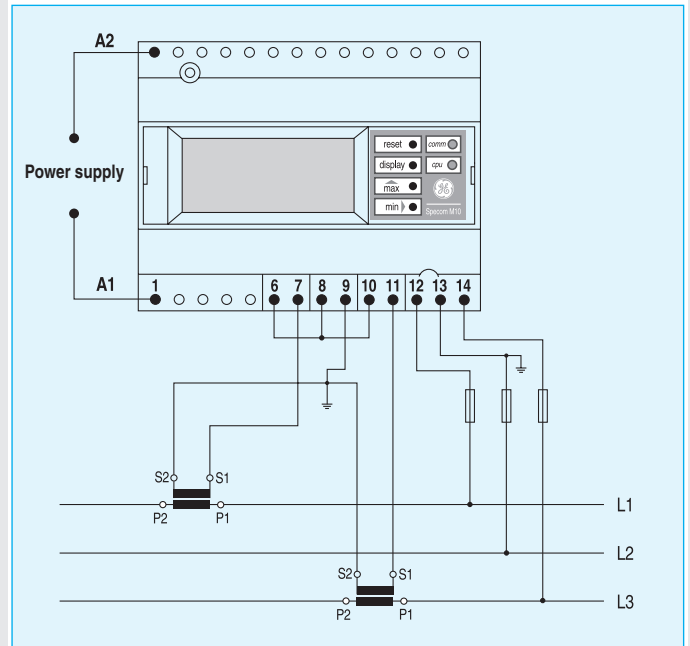

Three wire system without neutral (3 current transformers)

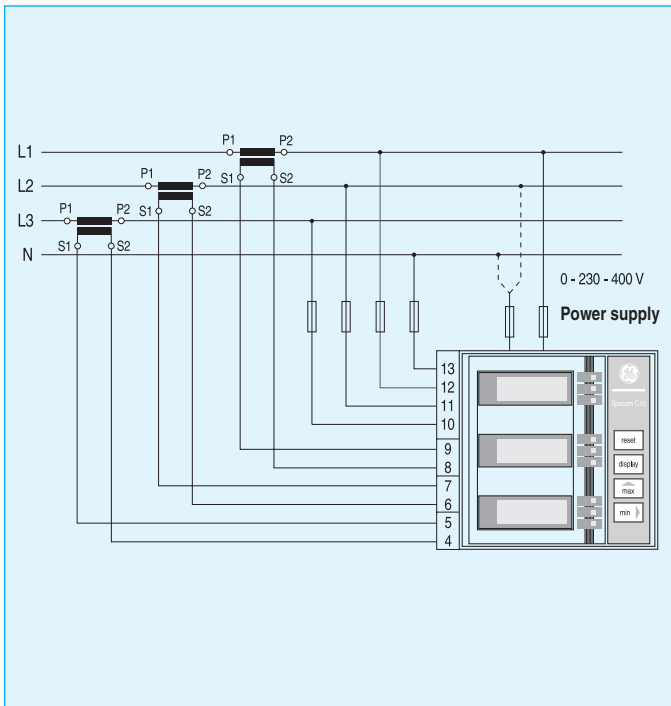

Three wire system without neutral (3 current transformers)

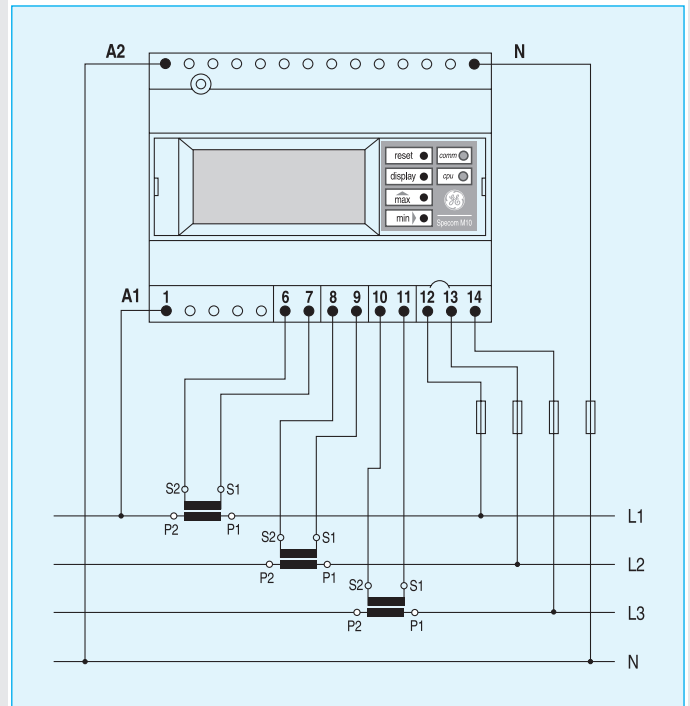



## Specom C

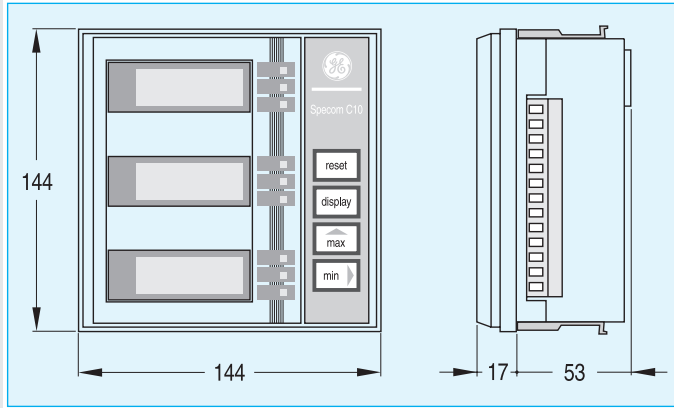

## Specom M

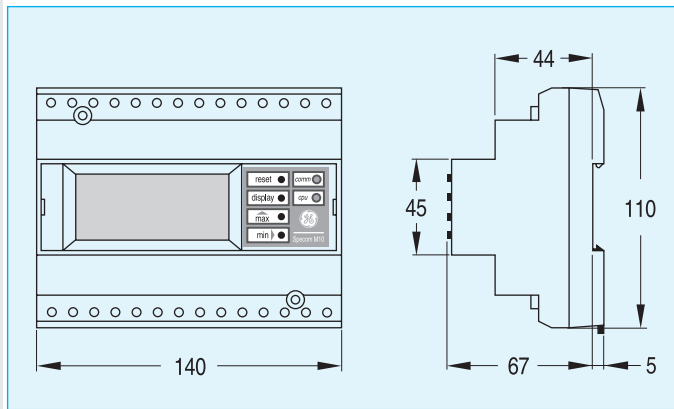

## Current transformer - Series MT

100 to 400A

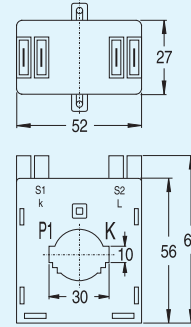

- 30 x 10 mm
- 26 x 13 mm
- 20 x 15 mm
- ø 24 mm

500 to 600A

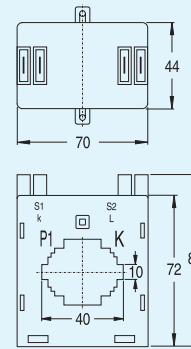

- 40 x 10 mm
- 30 x 15 mm
- 26 x 21 mm
- ø 28 mm

800 to 1000A

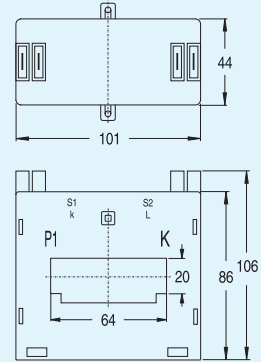

- 50 x 23 mm
- 63 x 20 mm
- 20 x ø 22 mm