



Record Plus

Technical data



GE imagination at work

- D.2 Performance figures
- D.4 Power dissipation
- D.8 Derating at temperatures other than 40°C
- D.10 Clearances (minimum safety distances)
- D.11 Use in individually mounted enclosures
- D.12 Current limitation
- D.14 Limitation curves (Energy & Current)
- D.16 Environmental considerations
- D.18 Use in DC networks
- D.19 Use at frequencies other than 50/60 cycles

The breaker

Order codes

Trip units

Components & Accessories

Technical data

Application guide

Wiring diagrams

Dimensions

Numerical Index

A

B

C

D

E

F

G

X

y on us





A

B

C

D

E

F

G

X

Circuit Breaker type		FD160			FD63/160						FE160		
Denomination		N	H	C	E	S	N	H	L	N	H	L	
EN 60947-2 standard													
Poles	Number of	1			3,4			2 ⁽¹⁾ 3,4			3,4		
Rated insulation voltage	Ui (Volts)	750			500 750 750			750			750		
Rated impulse withstand voltage	Uimp [Kilovolt]	3			6 8 8			8			8		
Rated operational voltage Ue	Volts AC	240			500 690 690			690			690		
	Volts DC	250			-			500			500		
Line protection device													
Category of use		A			A			A			A		
Suitable for use as a isolator		Positive ON & OFF			yes			yes			yes		
Rated current Ith = Ie		A at 40°C			63 or 160			63 or 160			160		
Ultimate breaking capacity Icu [kA]	230/240V AC	25	50	25	40	50	85	100	200	85	100	200	
	400/415V AC	-	-	18	25	36	50	80	150	50	80	150	
	440V AC	-	-	12	14	25	30	65	130 ⁽⁴⁾	42	65	130	
	500V AC	-	-	10	12	18	22	36	50 ⁽⁴⁾	30	50	100	
	690V AC	-	-	-	4.5	6	8	10	12	10	22	75	
	250V DC Single pole	-	50	-	-	25	40	65	100	50	85	100	
	500V DC Two pole	-	-	-	-	25	40	65 ⁽²⁾	100 ⁽²⁾	50	85 ⁽²⁾	100 ⁽²⁾	
Service breaking capacity Ics (%Icu)	≤ 500V	100%	100%	100%	75%	100%	100%	100%	100%	100%	100%	100%	
	690V AC	-	-	-	75%	75%	50%	50%	35%	100%	75%	25%	
Single phase breaking capacity I _{TP} [kA]	230V AC	25	50	16	25	30	50	80	150	50	80	150	
	400/415V AC	-	-	-	4.5	6	8	10	12	15	22	36	
Endurance (CO operations)	Mechanical	10000			10000			25000			40000		
	Electrical at In	5000			5000			10000			20000		
	Electrical at In/2	10000			10000			20000			30000		
Endurance (On-Tripped operations)	Mechanical	4000			4000			10000			16000		
	Trip Units	Interchangeable			no			no			yes		
Trip Units	Thermal magnetic line	LTM									LTM		
	Thermal magnetic generator							GTM			GTM		
	Thermal magnetic selective							LTMD			LTMD		
	Magnetic only							Mag Break™			Mag Break™		
	Electronic selective										SMR1		
	Electronic enhanced												
Circuit Breaker type and denomination		FD160Y			FD 63Y			FD160Y			FE160Y		
EN 60947-3 standard													
Non Automatic breaker (Switch)													
Rated current In (class AC23)	220V AC to 690V AC	160			63			160			160		
Rated making capacity	I _{cm} (kA peak)	2.8			1.7			2.8			4.9		
Short-term withstand current I _{cw} [kA]	I _{cw} eff. 1 second	2			1.2			2			3		
	I _{cw} eff. 3 seconds	2			1.2			2			3		
Circuit Breaker type								FD63/160			FE160		
Denomination								N H L			N H L		
EN 60947-4 standard													
Use in motor circuits													
Rated current Ith	A at 65°C							FD50-50 FD160-100			150		
Endurance (CO operations)	Mechanical							25000			40000		
	Electrical at In class AC23							10000			20000		
Protection	Operations per hour							120			120		
	Short-circuit only (sep. overload device)							Mag Break™			Mag Break™		
	Overload class 10 and short-circuit										SMR1		
	Max In (A) class 10							FD63-50 FD160-100			150		
	Max In (A) class 30							FD63-50 FD160-80			150		
Earth fault unit (differential)							Optional FDQ type			Optional FEQ type			
Circuit Breaker / Switch type					FD63/160 all types						FE160 all types		
NEMA AB1 standard													
3ph. interruption ratings [kA]	240V AC	-	-	-	-	50	65	100	-	100	150	200	
	480V AC	-	-	-	-	25	36	50	-	50	65	130	
	600V AC	-	-	-	-	6	8	10	-	25	36	42	
Installation													
Mounting	On symmetrical DIN Rail	yes			yes			yes			no		
	Fixed	yes			yes			yes			yes		
	Plug in	no			yes			yes			yes		
	Draw out	no			no			no			yes		
Connection	Front	yes			yes			yes			yes		
	Rear	no			no			yes			yes		
Dimensions [w x h x d] mm	3 pole, fixed front connection	27 x 130 x 85			81 x 130 x 85			81 x 130 x 85			105 x 170 x 95		
	4 pole, fixed front connection	for single pole			108 x 130 x 85			108 x 130 x 85			140 x 170 x 95		
Weights [kg]	3 pole, fixed front connection	0.4			0.9			0.9			1.5		
	4 pole, fixed front connection	for single pole			1.3			1.3			2.0		

(1) N type only. (2) Use 3 poles. (3) Use 2 poles. (4) 160A rating only; derate to 65kA at 440V and 36kA at 500V.





FE250				FG400			FG630			FK800			FK1250			FK1600	
V	N	H	L	N	H	L	N	H	L	N	H	L	N	H	L	N	H
3,4				3,4			3,4			3,4			3,4			3,4	
690	750			750			750			1000			1000			1000	
8	8			8			8			8			8			8	
500	690			690			690			690			690			690	
440	500			-			-			500			500			500	
A				B ⁽⁵⁾			B ⁽⁵⁾			B			B			B	
yes				yes			yes			yes			yes			yes	
250				400			630			800			1250			1600	
65	85	100	200	85	100	200	85	100	200	85	100	170	85	100	170	85	100
36	50	80	150	50	80	150	50	80	150	50	80	100	50	80	100	50	80
25	42	65	130	42	65	130	42	65	130	42	65	80	42	65	80	42	65
18	30	50	100	30	50	100	30	50	100	36	42	50	36	42	50	36	42
-	10	15	22	10	22	75 ⁽⁷⁾	10	22	40 ⁽⁷⁾	20	25	30	20	25	30	20	25
25	50	85	100							50 ⁽³⁾	60 ⁽³⁾	80 ⁽³⁾	50 ⁽³⁾	60 ⁽³⁾	80 ⁽³⁾	-	-
-	50	85 ⁽²⁾	100 ⁽²⁾							36 ⁽²⁾	50 ⁽²⁾	60 ⁽²⁾	36 ⁽²⁾	50 ⁽²⁾	60 ⁽²⁾	-	-
100%	100%	100%	100%	100%	100%	100%	100%	100%	100%	100%	75%	50%	100%	75%	50%	100%	75%
-	100%	75%	50%	100%	45%	25%	100%	45%	25%	100%	75%	50%	100%	75%	50%	100%	75%
36	50	80	150	50	80	150	50	80	150	50	80	100	50	80	100	50	80
-	10	15	22	10	(6)	(6)	10	(6)	(6)	20	25	30	20	25	30	20	25
10000	25000			20000			20000			10000			10000			10000	
5000	10000			7500			5000			4000			3000			2000	
10000	20000			15000			10000			8000			6000			4000	
4000	10000			8000			8000			4000			3000			2000	
no	yes			yes			yes			no			no			no	
LTM										LTM			LTM				
	GTM																
	LTMD																
	Mag Break™						Mag Break™										
	SMR1						SMR1						SMR1e				
							SMR2						SMR 1s & g				
FE250Y				FG400Y			FG630Y			FK800Y			FK1250Y			FK1600Y	
250				400			630			800			1250			1600	
6.4				8.5			11.3			14.1			21.2			28.3	
4				5			6.5			10			15			20	
4				5			6.5			10			15			20	
FE250				FG400			FG630			FK800			FK1250			FK1600	
N	H	L		N	H	L	N	H	L	N	H	L	N	H	L	N	H
225				350			500			720			1000				
25000				20000			20000			10000			10000				
10000				7500			5000			4000			3000				
120				120			60			60			60				
Mag Break™				Mag Break™			Mag Break™			Mag Break™			Mag Break™				
SMR1				SMR1 or SMR2			SMR1 or SMR2										
225				350			500			720			1000				
225				350			500			720			1000				
Optional FEQ type				Optional FGQ type			Optional FGQ type										
FE250 all types				FG400 all types			FG630 all types			FK800 all types			FK1250 all types			FK1600 all types	
65	100	150	200	100	150	200	100	150	200	85	-	-	85	-	-	85	-
36	50	65	130	50	65	130	50	65	130	42	-	-	42	-	-	42	-
22	25	36	42	25	36	42	25	36	42	25	-	-	25	-	-	25	-
no				no			no			no			no			no	
yes				yes			yes			yes			yes			yes	
yes				yes			yes			no			no			no	
yes				yes			yes			yes			yes			yes	
yes				yes			yes			yes			yes			yes	
yes				yes			yes			yes			yes			yes	
105 x 170 x 95				140 x 265 x 115			140 x 265 x 115			210 x 320 x 160			210 x 320 x 160			210 x 320 x 160	
140 x 170 x 95				185 x 265 x 115			185 x 265 x 115			280 x 320 x 160			280 x 320 x 160			280 x 320 x 160	
1.6				4.5			4.5			12.2			18.0			18.0	
2.1				6.0			6.0			15.1			23.4			23.4	

(5) 350 and 500A executions only
 (6) Please contact us.

(7) On use of FG400 and FG630L type at 690V, one long and widened terminal shield is required.



Power dissipation

Standards

The standard for low voltage equipment is defined in the EN 60439-1, the EN 50298 and the IEC 60890. These provide a theoretical method to calculate the temperature rise within an enclosure. The main element in these calculations is the power dissipation of the equipment installed. By totalizing this value for all the installed devices, connections, cables and busbars it is possible to calculate the temperature rise within the enclosure. Here, for normal applications a temperature rise within the enclosure of 50 Kelvin is assumed.

The absolute value of this temperature may not exceed 70°C (the sum of the ambient temperature in Celsius and the temperature rise in Kelvin).



Use

An enclosure manufacturer can provide the exact data on the allowable power dissipation within a certain enclosure. The values depend on the enclosure type, the ventilation it offers and on where the components are located within this enclosure. The example here is based on the GE Modula 630 enclosure type. The table indicates the temperature rise within a certain enclosure dimension. This at the top and middle of the enclosure in function of the installed heat dissipation (products) in Watt.



Mounted on wall - Temperature rise [Kelvin]

DISSIPATION (Watt)	500x500		500x750		750x500		750x750		750x1000		750x1250		1000x500		1000x750		1000x1000		1000x1250		1250x750		1250x1000	
	Middle	Top	Middle	Top	Middle	Top	Middle	Top	Middle	Top	Middle	Top	Middle	Top	Middle	Top	Middle	Top	Middle	Top	Middle	Top	Middle	Top
10	4	5	4	4	4	5																		
20	8	9	7	7	6	8	5	6	4	5			5	7										
30	11	13																						
40	13	16	11	13	11	14	9	11	7	9	6	7	9	13	7	9	5	7	5	6	5	8		
50	16	19																						
60	19	22	16	18	16	19	12	16	10	12	8	10	12	18	10	13	7	10	6	8	8	11	6	8
70	21	25																						
80	23	28	20	23	20	24	15	20	12	16	10	12	16	22	12	16								
90	26	31																						
100	28	33	24	27	23	29	18	23	15	19	12	14	19	27	14	19	11	14	9	12	11	16	9	13
120	32	38	28	31	27	33	21	27	40	32	40	22	31	17	23									
140	37	44	31	35	31	38	24	31	19	24	15	19	25	35	19	26	15	19	12	16	15	21	12	16
160	41	48	35	39	34	42	27	34					27	39	21	28								
180	45	53	38	43	38	46	29	38	24	30	19	23	30	43	23	31	18	23	15	19	18	25	15	20
200	49	58	42	47	41	51	32	41					33	47	25	34								
220	53	63	45	51	44	55	34	44	28	35	22	27	35	50	27	37	21	27	18	23	21	30	18	24
240			48	55	47	58	37	47					38	54	29	39								
260			52	58	51	62	39	51	32	40	25	31	40	58	31	42	24	31	20	26	24	34	20	27
280							42	54					43	61	33	45								
300							44	57	36	45	28	35	45	65	35	47	27	35	23	29	27	38	23	30
350							50	64	40	51	32	40	51	73	40	53	30	39	26	33	31	43	25	34
400									45	57	36	44			44	59	34	44	29	37	34	48	28	38
450									49	62	39	48			48	65	37	48	32	40	38	53	31	42
500															53	71	40	53	34	44	41	58	34	46
550																	44	57	37	47	45	63	37	49
600																	47	61	40	51	48	67	39	53
650																	42	54	51	72	42	57		
700																			45	57		45	60	
750																			48	61		47	63	
800																			50	64		50	67	



Record Plus™ Power dissipation

The power dissipation tables included here indicate the DC resistance of the **Record Plus™** breakers in cold condition. The power dissipation per pole can be calculated with this value and the average current flowing within the circuit (formula I^2R).

The tables indicate the Watt loss per pole based on the maximum current load of the breaker. To calculate the total Watt loss for a three or four pole breaker these values are multiplied by three.*

* for circuits with a high 3rd harmonic content, please contact us

Power Dissipation - FD63 frame

	In (A) ⁽¹⁾	Thermal magn. type (LTM, LTMD, GTM)							Mag Break™ (MO)						Switch (V)
		16	20	25	32	40	50	63	3	7	12.5	20	30	50	
Fixed version	R in mΩ per pole	11.00	5.70	4.00	2.90	2.90	2.25	1.60	110.00	55.00	17.85	10.65	4.75	3.00	0.40
	Dissipation Watt single pole	2.82	2.28	2.50	2.97	4.64	5.63	6.35	0.99	2.70	2.79	4.26	4.28	7.50	1.59
	Dissipation Watt three poles	8.45	6.84	7.50	8.91	13.92	16.88	19.05	2.97	8.09	8.37	12.78	12.83	22.50	4.76
Plug-in version	R in mΩ per pole	11.07	5.77	4.07	2.97	2.97	2.32	1.67	110.07	55.07	17.92	10.72	4.82	3.07	0.47
	Dissipation Watt single pole	0.28	0.44	0.69	0.75	1.17	1.83	2.91	0.99	2.70	2.80	0.31	0.47	1.31	1.87
	Dissipation Watt three poles	0.84	1.32	2.06	2.25	3.52	5.50	8.73	2.97	8.10	8.40	0.94	1.42	3.94	5.60
Fixed version with RCD	R in mΩ per pole	11.08	5.78	4.08	2.98	2.98	2.33	1.68	110.08	55.08	17.93	10.73	4.83	3.08	0.48
	Dissipation Watt single pole	0.29	0.45	0.70	0.76	1.19	1.87	2.96	0.99	2.70	2.80	0.33	0.50	1.39	1.91
	Dissipation Watt three poles	0.86	1.34	2.10	2.29	3.58	5.60	8.89	2.97	8.10	8.40	1.00	1.50	4.18	5.72
Plug-in version with RCD	R in mΩ per pole	11.15	5.85	4.15	3.05	3.05	2.40	1.75	110.15	55.15	18.00	10.80	4.90	3.15	0.55
	Dissipation Watt single pole	0.31	0.49	0.76	0.83	1.30	2.03	3.23	0.99	2.70	2.81	0.36	0.54	1.51	2.18
	Dissipation Watt three poles	0.94	1.46	2.29	2.50	3.90	6.10	9.68	2.97	8.11	8.44	1.09	1.63	4.54	6.55

Power Dissipation - FD160 frame

	In (A)	Thermal magn. type (LTM, LTMD, GTM)				Mag Break™ (MO)		Switch (V)
		80	100	125	160	80	100	
Fixed version	R in mΩ per pole	0.95	0.70	0.40	0.40	0.45	0.45	0.40
	Dissipation Watt single pole	6.08	7.00	6.25	10.24	2.88	4.50	10.24
	Dissipation Watt three poles	18.24	21.00	18.75	30.72	8.64	13.50	30.72
Plug-in version	R in mΩ per pole	1.02	0.77	0.47	0.47	0.52	0.52	0.47
	Dissipation Watt single pole	6.53	7.70	7.34	12.03	3.33	5.20	12.03
	Dissipation Watt three poles	19.58	23.10	22.03	36.10	9.98	15.60	24.06
Fixed version with RCD	R in mΩ per pole	1.03	0.78	0.48	0.48	0.53	0.53	0.48
	Dissipation Watt single pole	6.59	7.80	7.50	12.29	3.39	5.30	12.29
	Dissipation Watt three poles	19.78	23.40	22.50	36.86	10.18	15.90	36.86
Plug-in version with RCD	R in mΩ per pole	1.10	0.85	0.55	0.55	0.60	0.60	0.55
	Dissipation Watt single pole	7.04	8.50	8.59	14.08	3.84	6.00	14.08
	Dissipation Watt three poles	21.12	25.50	25.78	42.24	11.52	18.00	42.24

Power Dissipation - FE160 frame

	In (A)	Thermal magn. type (LTMD, GTM)								Switch (V)					
		25	32	40	50	63	80	100	125		160				
Fixed version	R in mΩ per pole	6.30	2.80	2.80	2.05	1.80	1.20	0.70	0.63	0.48	0.30				
	Dissipation Watt single pole	3.94	2.87	4.48	5.13	7.14	7.68	7.00	9.84	12.29	7.68				
	Dissipation Watt three poles	11.81	8.60	13.44	15.38	21.43	23.04	21.00	29.53	36.86	23.04				
Plug-in version	R in mΩ per pole	6.36	2.86	2.86	2.11	1.86	1.26	0.76	0.69	0.54	0.36				
	Dissipation Watt single pole	3.98	2.93	4.58	5.28	7.38	8.06	7.60	10.78	13.82	5.63				
	Dissipation Watt three poles	11.93	8.79	13.73	15.83	22.15	24.19	22.80	32.34	41.47	11.25				
Fixed version with RCD	R in mΩ per pole	6.37	2.87	2.87	2.12	1.87	1.27	0.77	0.70	0.55	0.38				
	Dissipation Watt single pole	3.98	2.94	4.59	5.30	7.42	8.13	7.70	10.94	14.08	5.94				
	Dissipation Watt three poles	11.94	8.82	13.78	15.90	22.27	24.38	23.10	32.81	42.24	17.81				
Plug-in version with RCD	R in mΩ per pole	6.43	2.93	2.93	2.18	1.93	1.33	0.83	0.76	0.61	0.44				
	Dissipation Watt single pole	4.02	3.00	4.69	5.45	7.66	8.51	8.30	11.88	15.62	11.56				
	Dissipation Watt three poles	12.06	9.00	14.06	16.35	22.98	25.54	24.90	35.63	46.85	33.79				
	In (A) ⁽¹⁾	Mag Break™ (MO)								FE160 frame electronic type (SMR1)					
		3	7	12.5	20	30	50	80	100	125	160	25	63	125	160
Fixed version	R in mΩ per pole	410.00	110.00	13.30	13.30	3.60	1.70	0.60	0.60	0.32	0.32	0.35	0.35	0.35	0.35
	Dissipation Watt single pole	5.02	5.39	2.08	5.32	3.24	4.25	3.84	6.00	3.84	3.84	0.22	1.39	5.47	8.96
	Dissipation Watt three poles	15.07	16.17	7.27	15.96	11.34	12.75	11.52	18.00	11.52	11.52	0.66	4.17	16.41	26.88
Plug-in version	R in mΩ per pole	410.06	110.06	13.36	13.36	3.66	1.76	0.66	0.66	0.38	0.38	0.41	0.41	0.41	
	Dissipation Watt single pole	5.02	5.39	2.09	5.34	3.29	4.40	4.22	6.60	5.94	9.73	0.26	1.63	6.41	10.50
	Dissipation Watt three poles	15.07	16.18	6.26	16.03	9.88	13.20	12.67	19.80	17.81	29.18	0.77	4.88	19.22	31.49
Fixed version with RCD	R in mΩ per pole	410.07	110.07	13.37	13.37	3.67	1.77	0.67	0.67	0.39	0.39	0.42	0.42	0.42	
	Dissipation Watt single pole	5.02	5.39	2.09	5.35	3.30	4.43	4.29	6.70	6.09	9.98	0.26	1.67	6.56	10.75
	Dissipation Watt three poles	15.07	16.18	6.27	16.04	9.91	13.28	12.86	20.10	18.28	29.95	0.79	5.00	19.69	32.26
Plug-in version with RCD	R in mΩ per pole	410.13	110.13	13.43	13.43	3.73	1.83	0.73	0.73	0.45	0.45	0.48	0.48	0.48	
	Dissipation Watt single pole	5.02	5.40	2.10	5.37	3.36	4.58	4.67	7.30	7.03	11.52	0.30	1.91	7.50	12.29
	Dissipation Watt three poles	15.07	16.19	6.30	16.12	10.07	13.73	14.02	21.90	14.02	14.02	0.90	5.72	22.50	36.86

(1) All 3A magnetic only ratings can be used at 3.5A



Power Dissipation - FE250 frame

	In (A)	Thermal magn. type (LTMD, GTM)						Switch (Y)
		80	100	125	160	200	250	
Fixed version	R in mΩ per pole	1.10	0.60	0.55	0.40	0.33	0.24	0.20
	Dissipation Watt single pole	7.04	6.00	8.59	10.24	13.20	15.00	12.50
	Dissipation Watt three poles	21.12	18.00	25.78	30.72	39.60	45.00	37.50
Plug-in version	R in mΩ per pole	1.16	0.66	0.61	0.46	0.39	0.30	0.26
	Dissipation Watt single pole	7.42	6.60	9.53	11.78	15.60	18.75	16.25
	Dissipation Watt three poles	22.27	19.80	28.59	35.33	46.80	56.25	48.75
Fixed version with RCD	R in mΩ per pole	1.17	0.67	0.62	0.47	0.40	0.31	0.27
	Dissipation Watt single pole	7.49	6.70	9.69	12.03	16.00	19.38	16.88
	Dissipation Watt three poles	22.46	20.10	29.06	36.10	48.00	58.13	50.63
Plug-in version with RCD	R in mΩ per pole	1.23	0.73	0.68	0.53	0.46	0.37	0.33
	Dissipation Watt single pole	7.87	7.30	10.63	13.57	18.40	23.13	20.63
	Dissipation Watt three poles	23.62	21.90	31.88	40.70	55.20	69.38	61.88

	In (A)	Mag Break™(MO)			FE250 frame Electronic type (SMR1)			Switch (Y)
		160	200	250	125	160	250	
Fixed version	R in mΩ per pole	0.33	0.24	0.20	0.20	0.20	0.20	
	Dissipation Watt single pole	8.45	2.40	15.00	3.13	5.12	12.50	
	Dissipation Watt three poles	25.34	7.20	45.00	9.38	15.36	37.50	
Plug-in version	R in mΩ per pole	0.39	0.30	0.30	0.26	0.26	0.26	
	Dissipation Watt single pole	9.98	3.00	18.75	4.06	6.66	16.25	
	Dissipation Watt three poles	29.95	9.00	56.25	12.19	19.97	48.75	
Fixed version with RCD	R in mΩ per pole	0.40	0.31	0.31	0.27	0.27	0.27	
	Dissipation Watt single pole	10.24	3.10	19.38	4.22	6.91	16.88	
	Dissipation Watt three poles	30.72	9.30	58.13	12.66	20.74	50.63	
Plug-in version with RCD	R in mΩ per pole	0.46	0.37	0.37	0.33	0.33	0.33	
	Dissipation Watt single pole	11.78	3.70	23.13	5.16	8.45	20.63	
	Dissipation Watt three poles	35.33	11.10	69.38	15.47	25.34	61.88	

Power Dissipation - FG400 & FG 630 frame

	In (A)	FG400/630 frame electronic type (SMR1 & 2)					Mag Break™(MO)		Switch (Y)	
		250	350	400	500	630	350	500	400	630
Fixed version	R in mΩ per pole	0.11	0.11	0.11	0.10	0.10	0.11	0.10	0.11	0.10
	Dissipation Watt single pole	6.88	13.48	17.60	25.00	39.69	13.48	23.75	17.60	39.69
	Dissipation Watt three poles	20.63	40.43	52.80	75.00	119.07	40.43	71.25	52.80	119.07
Plug-in/Draw-out version	R in mΩ per pole	0.13	0.13	0.13	0.12	0.12	0.13	0.12	0.13	0.12
	Dissipation Watt single pole	8.13	15.93	20.80	30.00	47.63	15.93	30.00	20.80	47.63
	Dissipation Watt three poles	24.38	47.78	62.40	90.00	142.88	47.78	90.00	62.40	142.88
Fixed version with RCD	R in mΩ per pole	0.16	0.16	0.16	0.15	0.15	0.16	0.15	0.16	0.15
	Dissipation Watt single pole	10.00	19.60	25.60	37.50	59.54	19.60	37.50	25.60	59.54
	Dissipation Watt three poles	30.00	58.80	76.80	112.50	178.61	58.80	112.50	76.80	178.61
Plug-in/Draw-out version with RCD	R in mΩ per pole	0.16	0.17	0.17	0.17	0.17	0.17	0.17	0.17	0.17
	Dissipation Watt single pole	10.00	20.21	26.40	41.25	65.49	20.21	41.25	26.40	65.49
	Dissipation Watt three poles	30.00	60.64	79.20	123.75	196.47	60.64	123.75	79.20	196.47

Power Dissipation - FK800, FK1250 & FK1600 frame

	In (A)	Thermal magn. type (LTM)				Mag Break™(MO)		Switch (Y)		
		630	800	1000	1250	800	1250	800	1250	1600
Fixed version	R in mΩ per pole	0.04	0.04	0.04	0.04	0.02	0.02	0.02	0.02	0.01
	Dissipation Watt single pole	15.88	25.60	35.00	54.69	12.80	23.44	12.80	31.25	25.60
	Dissipation Watt three poles	47.63	76.80	105.00	164.06	38.40	70.31	38.40	93.75	76.80
Draw-out version	R in mΩ per pole	0.07	0.07	0.07	0.07	0.05	0.05	0.05	0.05	0.04
	Dissipation Watt single pole	27.78	44.80	65.00	101.56	32.00	70.31	32.00	78.13	102.40
	Dissipation Watt three poles	83.35	134.40	195.00	304.69	96.00	210.94	96.00	234.38	307.20

	In (A)	FK800,1250-1600 frame electronic type (SMR1e, s & g)			
		800	1000	1250	1600
Fixed version	R in mΩ per pole	0.04	0.04	0.04	0.03
	Dissipation Watt single pole	25.60	35.00	54.69	76.80
	Dissipation Watt three poles	76.80	105.00	164.06	230.40
Draw-out version	R in mΩ per pole	0.07	0.07	0.07	0.06
	Dissipation Watt single pole	25.60	35.00	54.69	76.80
	Dissipation Watt three poles	76.80	105.00	164.06	230.40



Notes

Grid area for notes.

Power dissipation

A
B
C
D
E
F
G
X



Derating

Thermal magnetic trip units

The ambient temperature in the direct vicinity of a protective device has an influence on its current carrying properties.

The **Record Plus™** breakers with thermal magnetic and magnetic only protection units as the MO, LTM and LTMD types can be used at currents and temperatures as indicated in the table.

Maximum permissible current at an ambient temperature of

Type	In (A)	Fixed breaker							Plug in or drawout breaker						
		40°C	45°C	50°C	55°C	60°C	65°C	70°C	40°C	45°C	50°C	55°C	60°C	65°C	70°C
FD63, FD160, FE160 & FE250	16	16.0	15.5	15.0	14.6	14.1	13.6	13.1	15.0	14.6	14.1	13.7	13.2	12.8	12.3
	25	25.0	24.3	23.5	22.8	22.0	21.3	20.5	23.5	22.8	22.1	21.4	20.7	20.0	19.3
	32	32.0	31.0	30.1	29.1	28.2	27.2	26.2	30.1	29.2	28.3	27.4	26.5	25.6	24.7
	40	40.0	38.8	37.6	36.4	35.2	34.0	32.8	37.6	36.5	35.3	34.2	33.1	32.0	30.8
	50	50.0	48.5	47.0	45.5	44.0	42.5	41.0	47.0	45.6	44.2	42.8	41.4	40.0	38.5
	63	63.0	61.1	59.2	57.3	55.4	53.6	51.7	59.2	57.4	55.7	53.9	52.1	50.3	48.6
	80	80.0	77.6	75.2	72.8	70.4	68.0	65.6	75.2	72.9	70.7	68.4	66.2	63.9	61.7
FD160	100	100	97.0	94.0	91.0	88.0	85.0	82.0	94.0	91.2	88.4	85.5	82.7	79.9	77.1
	125	125	121	118	114	110	106	103	118	114	110	107	103	100	96
	160	160	155	150	146	141	136	131							
FE160 & FE250	125	125	121	118	114	110	106	103	118	114	110	107	103	100	96
	160	160	155	150	146	141	136	131	150	146	141	137	132	128	123
	200	200	194	188	182	176	170	164	188	182	177	171	165	160	154
	250	250	243	235	228	220	213	205	235	228	221	214	207	200	193
FK800 & FK1250	630	630	611	592	573	554	536	517	630	611	563	545	527	509	491
	800	800	776	752	728	704	680	656	800	760	714	692	669	646	623
	1000	1000	970	940	910	880	850	820	1000	950	893	865	836	808	779
	1250	1250	1213	1175	1138	1100	1063	1025	1250	1188	1116	1081	1045	1009	974
FD63 & FD160 FE160 & FE250 with RCD	16	16.0	15.5	15.0	14.6	14.1	13.6	13.1	15.0	14.6	14.1	13.7	13.2	12.8	12.3
	25	25.0	24.3	23.5	22.8	22.0	21.3	20.5	23.5	22.8	22.1	21.4	20.7	20.0	19.3
	32	32.0	31.0	30.1	29.1	28.2	27.2	26.2	30.1	29.2	28.3	27.4	26.5	25.6	24.7
	40	40.0	38.8	37.6	36.4	35.2	34.0	32.8	37.6	36.5	35.3	34.2	33.1	32.0	30.8
	50	50.0	48.5	47.0	45.5	44.0	42.5	41.0	47.0	45.6	44.2	42.8	41.4	40.0	38.5
	63	63.0	61.1	59.2	57.3	55.4	53.6	51.7	59.2	57.4	55.7	53.9	52.1	50.3	48.6
	80	80.0	77.6	75.2	72.8	70.4	68.0	65.6	75.2	72.9	70.7	68.4	66.2	63.9	61.7
FD160 with RCD	100	100	97.0	94.0	91.0	88.0	85.0	82.0	94.0	91.2	88.4	85.5	82.7	79.9	77.1
	125	119	115	110	108	97	101	97	110	107	104	101	97	94	91
	160	152	147	141	138	125	129	125	141	137	133	129	124	120	116
FE160 & FE250 with RCD	125	125	121	118	114	110	106	103	118	114	110	107	103	100	96
	160	152	147	141	138	125	129	125	141	137	133	129	124	120	116
	200	190	184	177	173	156	162	156	177	171	166	161	156	150	145
	250	238	230	221	216	195	202	195	221	214	208	201	194	188	181

Technical data

A

B

C

D

E

F

G

X



Derating

Electronic trip units

Electronic trip units are less sensitive to fluctuations in ambient temperature than thermal magnetic trip units. However, to prevent the device and its environment from exceeding their design values, certain limits must be taken

into account. The table indicates the maximum values to which the LT or overload protection of the electronic trip unit of the **Record Plus™** breaker can be set. This at ambient temperatures from 40 to 70°C.

Maximum permissible current at an ambient temperature of

Type	Is ⁽¹⁾ (A)	Fixed breaker							Plug in or drawout breaker						
		40°C	45°C	50°C	55°C	60°C	65°C	70°C	40°C	45°C	50°C	55°C	60°C	65°C	70°C
FE160	25	25	25	25	25	25	25	25	25	25	25	25	25	25	25
	63	63	63	63	63	63	63	63	63	63	63	63	63	63	63
	125	125	125	125	125	125	125	125	125	125	125	125	125	125	125
	160	160	160	160	156	152	148	144	160	156	152	148	144	140	136
FE250	125	125	125	125	125	125	125	125	125	125	125	125	125	125	125
	160	160	160	160	160	160	160	160	160	156	152	148	144	140	136
	250	250	250	250	244	238	231	225	250	244	238	231	225	219	213
FG400	250	250	250	250	250	250	250	250	250	250	250	250	250	250	250
	350	350	350	350	350	350	350	350	350	350	350	350	350	350	340
	400	400	400	400	390	380	370	360	400	390	380	370	360	350	340
FG630	400	400	400	400	400	400	400	400	400	400	400	400	400	400	400
	500	500	500	500	500	500	500	500	500	500	500	500	500	500	481
	630	630	614	599	583	567	551	536	583	568	554	539	524	510	481
FK800	800	800	800	760	760	760	680	-	760	741	722	703	722	646	-
	1250	1000	1000	950	950	900	850	-	950	950	903	879	855	808	-
FK1250	1250	1250	1250	1188	1188	1125	1000	-	1188	1158	1128	1098	1069	950	-
	1600	1600	1600	1520	1440	1408	1280	-	1600	1536	1444	1408	1368	1216	-
FE160 with RCD	25	25	25	25	25	25	25	25	25	25	25	25	25	25	25
	63	63	63	63	63	63	63	63	63	63	63	63	63	63	63
	125	125	125	125	125	125	125	125	125	125	125	125	125	125	106
	160	160	156	152	148	144	141	137	152	148	144	141	137	133	129
FE250 with RCD	125	125	125	125	125	125	125	125	125	125	125	125	125	125	125
	160	160	160	160	160	160	160	160	160	160	160	160	160	160	160
	250	250	244	238	244	238	231	225	238	232	226	220	214	208	202
FG400 with RCD	250	250	250	250	250	250	250	250	250	250	250	250	250	250	250
	350	350	350	350	341	333	324	315	350	351	342	333	324	315	306
	400	400	370	360	350	340	330	320	360	351	342	333	324	315	306
FG630 with RCD	400	400	400	400	400	400	400	400	400	400	400	400	400	400	400
	500	500	500	500	500	500	500	488	500	500	494	481	468	455	442
	630	630	567	551	536	520	504	488	520	507	494	481	468	455	442

(1) Is = Sensor rating



Clearances

Minimum distances

A modern circuit breaker is designed to interrupt high short-circuit currents in a very limited time frame. In doing so the breaker vents gas and a limited amount of conductive fragments.

The **Record Plus™** circuit breaker has been designed to limit the venting phenomenon to a minimum. However, it is necessary to take the following minimum distances into account:

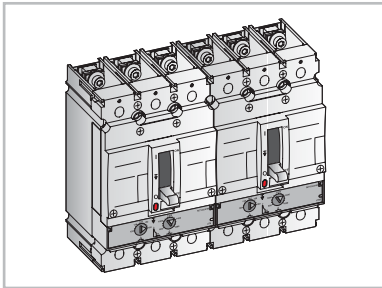

Minimum Distance between two side by side mounted **Record Plus™** Breakers = 0 mm

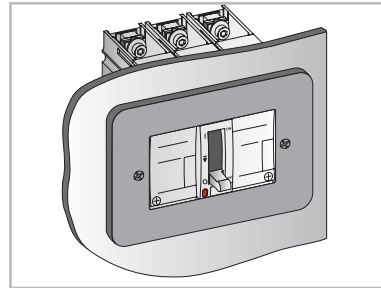

Minimum Distance to a front panel from a **Record Plus™** Breakers = 0 mm
Protection degree on breaker front = IP40

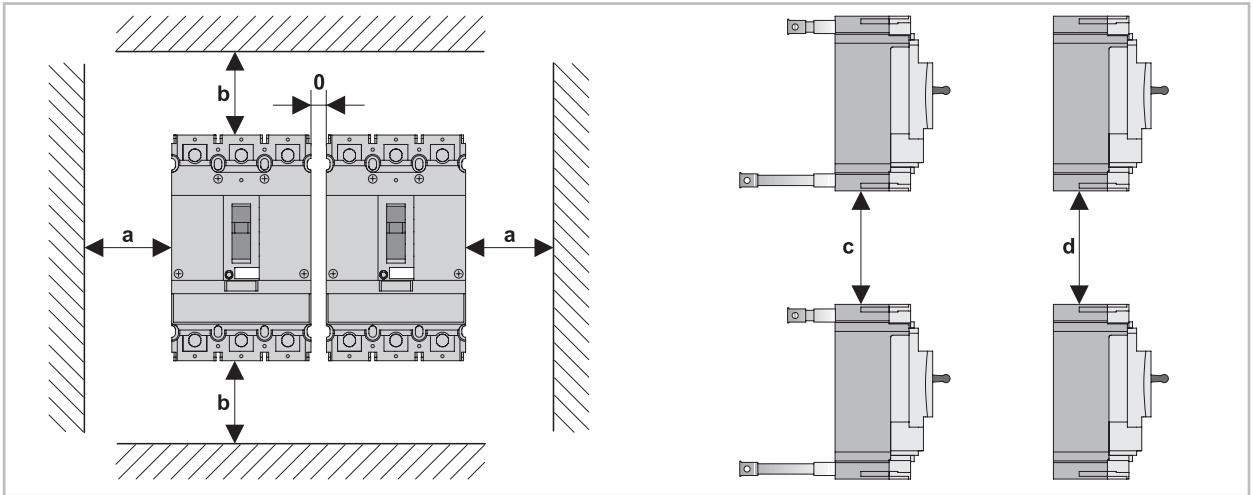

Minimum Distances

Type			Distances in mm				
			a	b	c	d	
FD63 & FD/160	To painted metal, non conductive materials and isolated conductors.	To unpainted metal	0	15			
			Voltage ≤ 480V	3	35		
			Voltage < 600V ⁽¹⁾	5	(2)		
		Voltage = 690V ⁽¹⁾	15	(2)			
	To breaker housing			35	35		
	To conductors protruding from breaker			35	35		
FE160 & FE250	To painted metal, non conductive materials and isolated conductors.	To unpainted metal	0	20			
			Voltage ≤ 480V	5	35		
			Voltage < 600V ⁽¹⁾	10	(2)		
		Voltage = 690V ⁽¹⁾	20	(2)			
	To breaker housing			35	35		
	To conductors protruding from breaker			35	35		
FG400 & FG630	To painted metal, non conductive materials and isolated conductors.	To unpainted metal	0	30			
			Voltage ≤ 480V	5	60		
			Voltage < 600V ⁽¹⁾	10	(2)		
		Voltage = 690V ⁽³⁾	20	(2)			
	To breaker housing			60	60		
	To conductors protruding from breaker			60	60		
FK800, FK 800 & FK1600	To painted metal, non conductive materials and isolated conductors.	To unpainted metal	0	40			
			Voltage ≤ 480V	15	80		
			Voltage < 600V	20	80		
		Voltage = 690V	30	80			
	To breaker housing			140	140		
	To conductors protruding from breaker			140	140		

(1) The use of phase separators and back plates is obligatory.
(2) Size determined by phase separators.

(3) At 690Volts the FG400L & FG630L must have the power supply connected to the breaker ON side (Line). In this application the use of the widened terminal shield is compulsory.

Individual mounting of Record Plus™ in enclosures

Record Plus™ breakers can be placed in enclosures for use as individually wall mounted feeder units. In order to ensure a reliable and practical solution each of the combinations mentioned here have been defined by strenuous testing. Here the properties of all components, and their use as a combination have been taken into account. For all other application of the **Record Plus™** in individually mounted enclosures, please contact us.



VMS, thermoplastic box IP65 with transparent cover.

The use of short or long terminal covers for the breaker is mandatory.

Breaker and terminal covers always have to be ordered separately.

Short-circuit rating: 20kA, 440 V

VMS, thermoplastic housing IP65 with opaque cover

Record Plus Breaker ⁽¹⁾ In (A)	Breaker type	Rotary handle type	Housing		Ref. nr.
			Size	Type	
125A	FD125 with and without RCD	FDNRC	440 x 320 x 254	VMS43 + extension frame	855085
160A	FE160	FENRC	440 x 320 x 254	VMS43 + extension frame	855087
160A	FE160 with RCD	FENRC	640 x 320 x 254	VMS63 + extension frame	855088
250A	FE250	FENRC	440 x 320 x 254	VMS43 + extension frame	855087
250A	FE250 with RCD	FENRC	640 x 320 x 254	VMS63 + extension frame	855088
400A	FG400 or FG 630	FGNRC	(2)	(2)	(2)
630A	FG400 or FG630 with RCD	FGNRC	(2)	(2)	(2)

PolySafe, glass fibre reinforced Polyester, cabinet IP65 with door.

When using **Record Plus™** Breaker in polyester cabinets for outdoor use we recommend encapsulating the

breaker in a VMS box.

Breaker, terminal covers and mounting plate for the external housing have to be ordered separately.

Short-circuit rating: 20kA, 440 V⁽³⁾

PolySafe, glass fibre reinforced polyester cabinet IP65

Record Plus Breaker ⁽¹⁾ In (A)	Breaker type	Internal housing VMS		External housing Polysafe	
		Size	Ref. nr.	Size	Ref. nr.
125A	FD125 w/out RCD	440 x 320 x 254	855085 ⁽³⁾	750 x 500 x 320	883008
160A	FE160 w/out RCD	640 x 320 x 254	855087 / 855088 ⁽³⁾	750 x 500 x 320	883008
250A	FE250 w/out RCD	640 x 320 x 254	855087 / 855088 ⁽³⁾	750 x 500 x 320	883008
400A	FG400 or FG 630	FGNRC	(2)	(2)	(2)
630A	FG400 or FG630 with RCD	FGNRC	(2)	(2)	(2)

(1) Ambient temperature max. 30 degrees centigrade.

(2) Please contact us.

(3)The use of short or long terminal covers on the breaker is mandatory

A

B

C

D

E

F

G

X

Current limitation

A short-circuit is an overcurrent with a value only limited by the impedance of the fault circuit itself. This impedance is determined by a number of factors the main ones of which are the available power that a network can supply and the impedance of the conductors within the fault circuit.

In modern hi-power electrical distribution networks very high prospective fault levels of 100kA or more can occur. High prospective short-circuit current values can cause issues in a number of areas:

Electrodynamic forces

These are proportional to the square of the crest current value

The electrodynamic forces due to the crest current value can seriously damage equipment as busbar systems and their supports, downstream switchgear etc.

Current limiting devices limit the crest value of the short-circuit current and thus reduce these forces.

Magnetic fields

A high level short-circuit produces magnetic fields that prevent electrical equipment as meters and computers from operating correctly.

Thermal stress (heat)

Thermal stress is proportional to the square of the effective current value.

The thermal stress limit of cable isolation, busbar supports and other electrical equipment can be expressed as an A²S value. This electrical energy value must be kept within certain pre-defined limits to prevent overheating.

To avoid or to limit the effects of these issues the use of current limiting devices is advisable.

Thermal stress in Electrical conductors

Cable have thermal stress limits normally expressed in a A²S value that depend on the cable's cross section and its isolation. It is limited to prevent the cable isolation from exceeding its temperature limits, the maximum values being specified in the HD 384.4.4.42 and HD 384.5.5.4 standards and paragraphs. The standards define the use of the formula:

$$K^2 \times S^2$$

K; factor provided in the standard; depends on the material that the conductor is made of and its insulation

S; cross section of the conductor

K factors according to HD 384

Insulation	Cu	Al
70°C PVC ≤ 300 sq.mm	115	76
70°C PVC > 300 sq.mm	103	68
90°C XLPE or EPR	143	94
85°C rubber	134	89

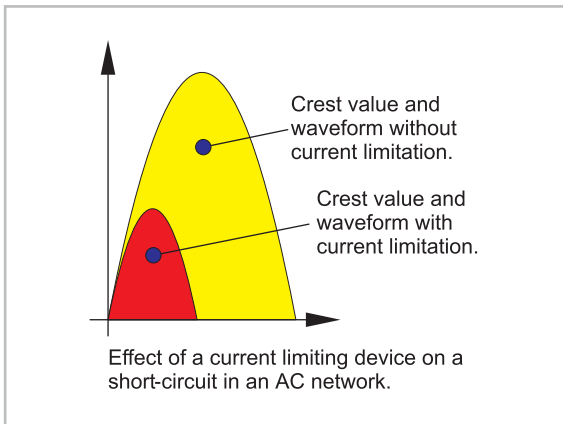

Maximum permissible thermal stress in conductors

Insulation	Core Material	S in mm ²	Thermal Stress Values												
			1.5	2.5	4	6	10	16	25	35	50	70	95	120	
			A ² S x10 ⁴	A ² S x10 ⁴	A ² S x10 ⁵	A ² S x10 ⁵	A ² S x10 ⁵	A ² S x10 ⁶	A ² S x10 ⁶	A ² S x10 ⁷	A ² S x10 ⁷	A ² S x10 ⁷	A ² S x10 ⁷	A ² S x10 ⁷	
70°C PVC	Copper		2.98	8.27	2.12	4.76	13.23	3.39	8.27	1.62	3.31	6.48	11.94	19.04	
	Aluminium		1.30	3.61	0.92	2.08	5.78	1.48	3.61	0.71	1.44	2.83	5.21	8.32	
90°C XLPE or EPR	Copper		4.60	12.78	3.27	7.36	20.45	5.23	12.78	2.51	5.11	10.02	18.46	29.45	
	Aluminium		1.99	5.52	1.41	3.18	8.84	2.26	5.52	1.08	2.21	4.33	7.97	12.72	
85°C rubber	Copper		4.04	11.22	2.87	6.46	17.96	4.60	11.22	2.20	4.49	8.80	16.21	25.86	
	Aluminium		1.78	4.95	1.27	2.85	7.92	2.03	4.95	0.97	1.98	3.88	7.15	11.41	

Record Plus™ MCCB's revolutionary design is equipped with dual contacts placed in a rotary configuration that enables the device to provide the highest available interruption ratings in the smallest possible size. When the breaker reacts it does so with more than twice the speed and force of conventional breakers, thus providing excellent current limitation. This results in low peak current and energy values in the circuit and leads to lower electro-dynamic forces and thermal stress values in the protected electrical conductors, downstream protection devices and equipment.

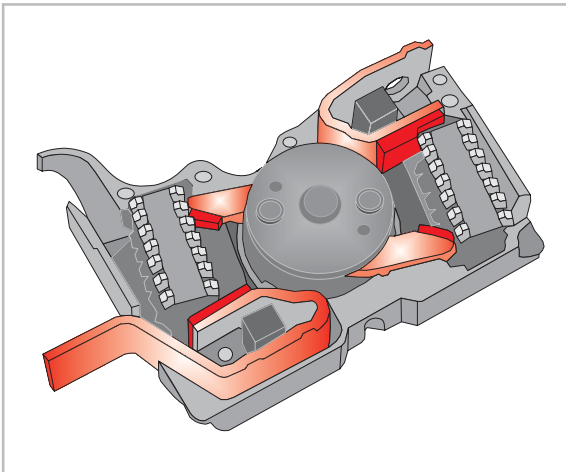

However, in some cases it is still necessary to check if the electrical conductors are protected correctly. This can be verified by taking the cable stress limits published on the previous page and comparing them with the let-through energy values found in the graphs.

The limitation of electrodynamic forces and thermal stress by using back-up protection

Protection devices placed downstream from a protective device as a **Record Plus™** breaker must be able to withstand the thermal and electrodynamic effects that occur at its point of installation. Placing current limiting devices upstream limits these values and can allow the use of smaller and more economical devices than is possible without the use of current limitation.

Back-up protection with **Record Plus™** is described in the application data section of this catalogue.

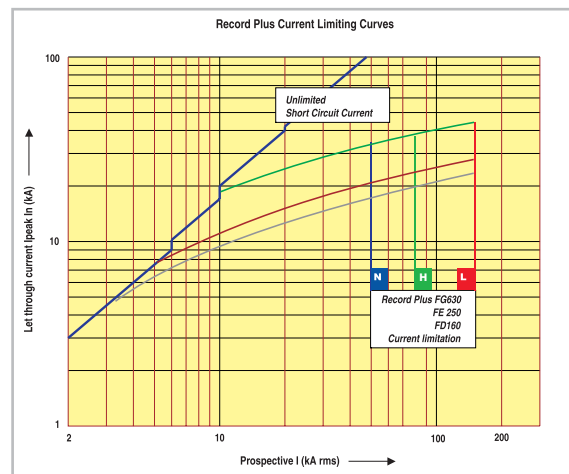

Current limitation data at 400/415V

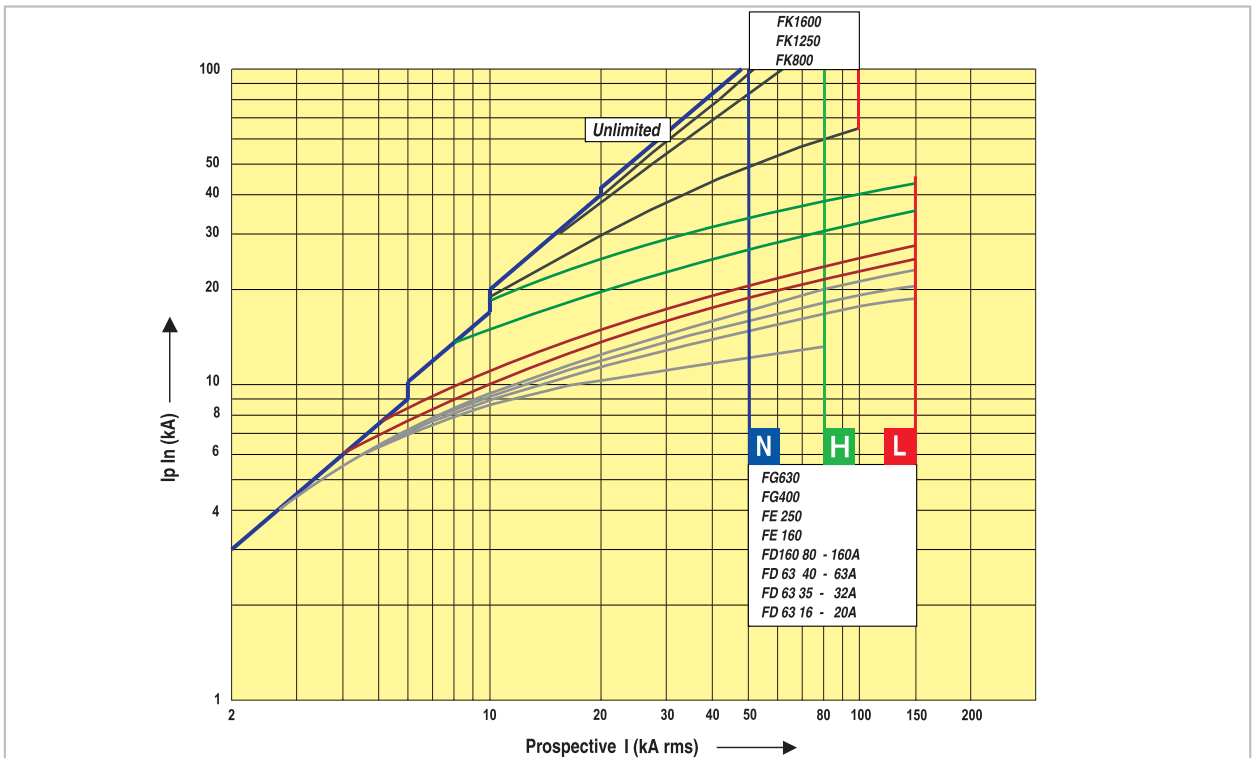

Thermal stress (Energy) Limitation data at 400/415V

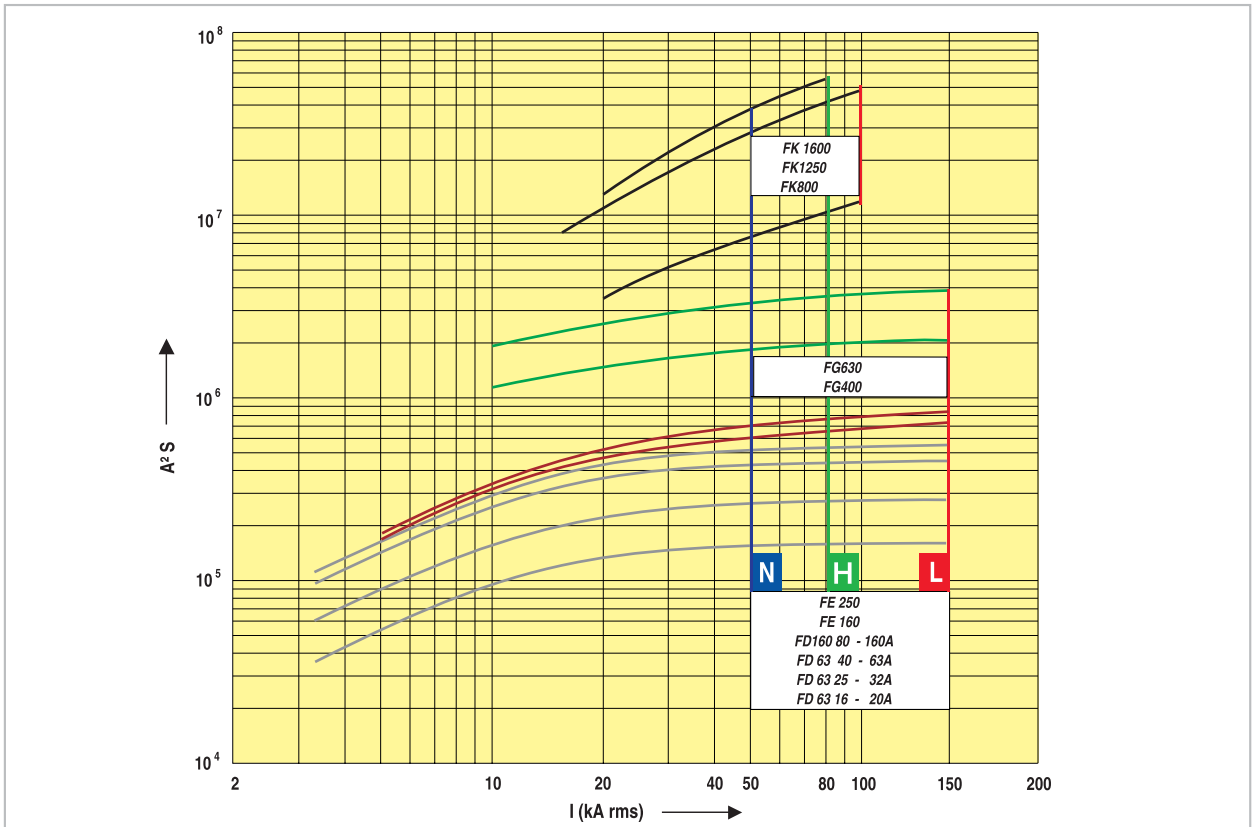

Technical data

A

B

C

D

E

F

G

X



Current limitation data at 690V

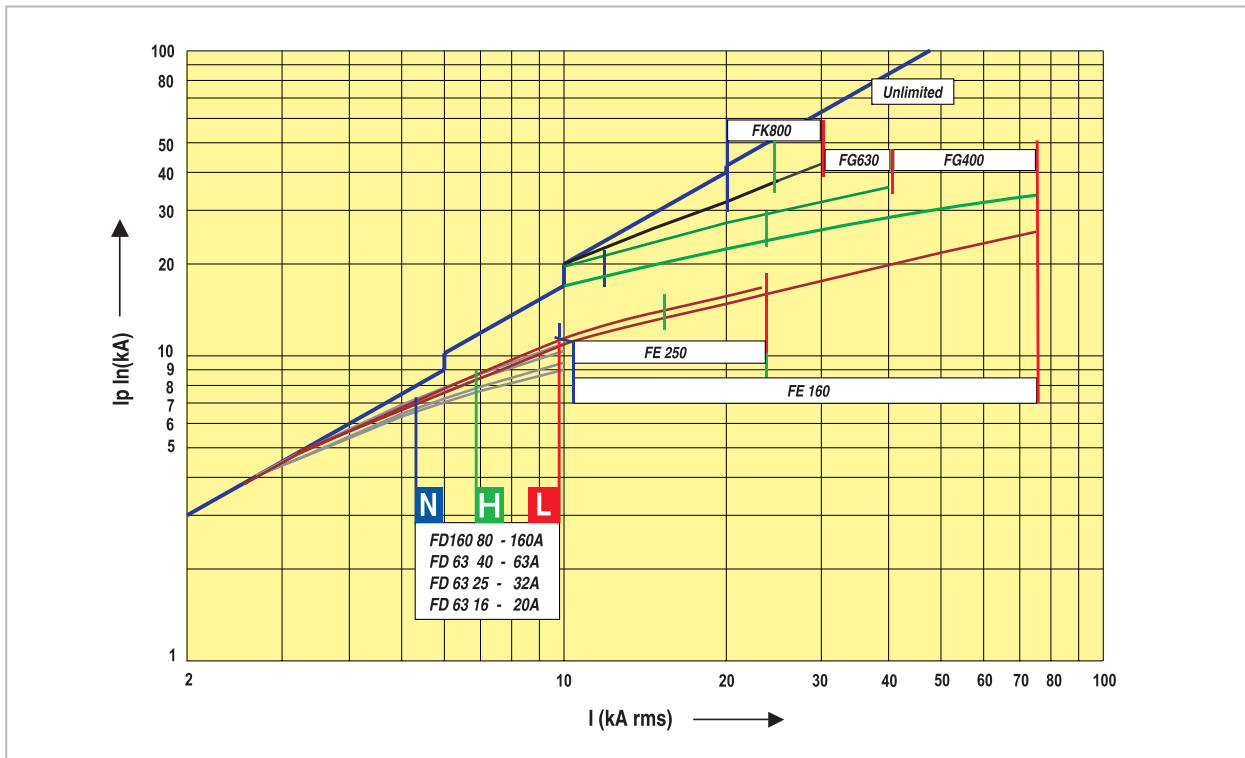

Thermal stress (Energy) Limitation data at 690V

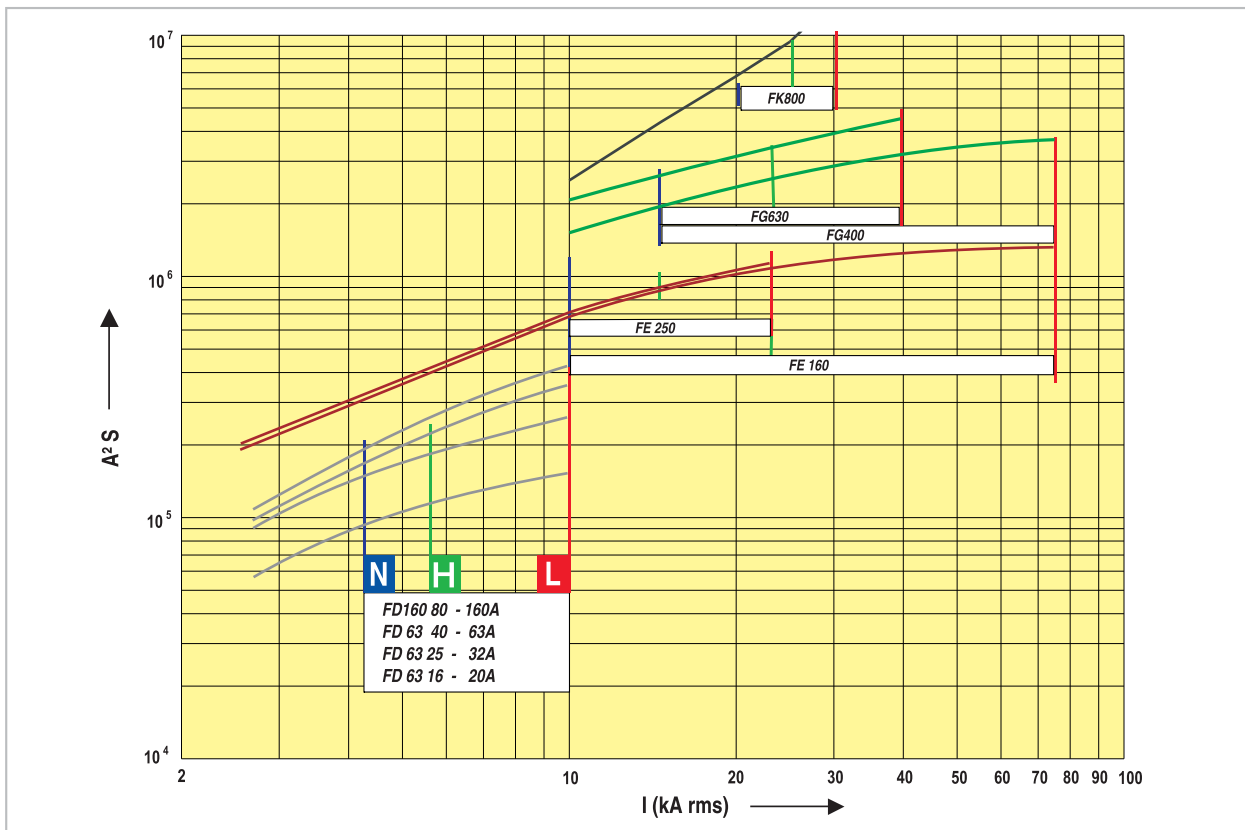

Environmental considerations

Ambient temperature

Record Plus™ breakers are designed to operate normally at temperatures of - 20 degrees to + 70°C. Above 40°C derating factors must be applied for two basic reasons:

- To prevent the materials used to construct the device from reaching temperatures that have an adverse effect on their mechanical and/or electrical properties.
- When the breakers is equipped with a thermal magnetic protection device the bimetal in the device will react to the heat generated by the current flowing through the device. Typical for this kind of device is that its reaction time speeds up at higher ambient temperatures.

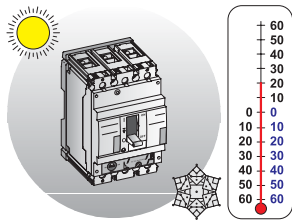

To achieve the same reaction time on a set current value it becomes necessary to derate. The time current curves published in this catalogue are always valid for operating temperatures between 10 and 40°C.

Storage temperature

A **Record Plus™** breaker is able to withstand non-operational storage temperature ranges of - 40 to + 85°C.

Influence of altitude

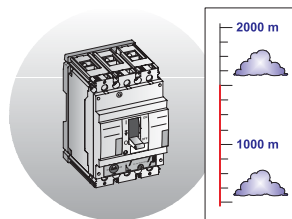

Up to altitudes of 2000 m above sea level no derating of breaker current or rated voltage is applicable. For altitudes above 2000 m the following factors apply:

Altitude

Altitude (meters)	3000m	4000m	5000m
Ue max. (Volts)	550V	480V	420V
Max. Thermal current at 40 degrees C	0.98 x In	0.93 x In	0.9 x In

Other atmospheric conditions

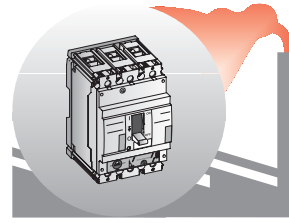

The breaker is designed to operate at the temperatures and relative humidities defined in the EN 60947 clause 6.1.3.1. It also meets the following standards:

IEC 68-2-1	Cold
IEC 68-2-2	Dry heat
IEC 68-2-11	Salt
IEC 68-2-14	Change of temperature
IEC 68-2-27	Shock test
IEC 68-2-29	Bump
IEC 68-2-30	Damp heat cyclic
IEC 68-2-31	Drop
MIL810F	Humidity

Shock & vibration

The **Record Plus™** line has been designed to withstand shock and vibration to the following standards:

IEC 68-2-6
Lloyd's Register of Shipping
Bureau Veritas
JIS 8370

More specifically: **Record Plus™** passed the following electro-mechanical tests:

Functions normally while being subjected to 30 minutes of random vibration with a power spectral density of 0.29g²/Hz in the range of 5Hz to 500Hz (3dB corner points, +-20dB/decade rolloff), this over three axes.

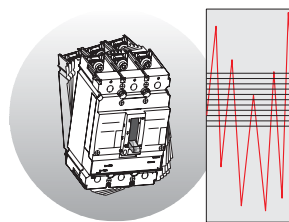

Functions normally while being subjected to sinusoidal vibration of 5g Peak from 10Hz to 500Hz using 30 minute sweeps with additional 30 minute dwells at the three

greatest resonance points in this frequency range, this over three axes.

The product is shock resitant and can withstand the following impacts in any possible orientation:
20g, 6ms, 10g, 11ms

Electromagnetic compatibility

Meets the most stringent requirement of the EN 60947-2 and IEC 1000-4. The breaker and electronic trip unit have passed the following tests.

Harmonics, current dips, interruptions and power frequency variations.

EN 60947-2 Annex F, Sub-clause F4.1 through 3
All requirements of non-sinusoidal currents resulting from harmonics are met i.e.:

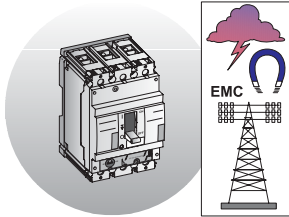

- Wave form consisting of a fundamental component + 3rd harmonic component at 50 and 60Hz
- Wave form consisting of a

fundamental component + a 5th harmonic component at 50 and 60Hz

- Composite wave form with a fundamental component + 3rd, 5th & 7th and a harmonic at 50 and 60Hz
- All current dips and current interruptions are met.
- Frequency variation test from 45Hz to 65Hz in 1Hz steps (required 50Hz to 60Hz in 1Hz steps)

Electrostatic discharge

EN 70947 Annex F, Sub-clause F6 and the IEC 1000-4-2 (basic standard)

- Passed level 4 air discharge 15kV

Radiated, radio frequency, electromagnetic field immunity test

EN 60947-2 Annex F, Sub-clause F7 and the IEC 1000-4-3 (basic standard)

- Passed higher than level 4.....field strength 30V/m

Electrical fast transient/burst

EN 60947-2 Annex F, Sub-clause F5 and the IEC 1000-4-4 (basic standard)

- Passed level 4 burst peak voltage 4kV

Surge immunity test

EN 60947-2 Annex F, Sub-clause F5 and the IEC 1000-4-5 (basic standard)

- Passed level 4 Voltage 1.2µs/50µs 6kV; current 8µs/20µs 3kA

Dry heat test

EN 60947-2 Annex F, Sub-clause F8

- Passed all test requirements

Thermal shock test

EN 60947-2 Annex F, Sub-clause F9

- No nuisance tripping within the 28-day temperature cycles

A

B

C

D

E

F

G

X

Use in DC networks

In both AC and DC networks protective devices are required to interrupt the prospective short-circuit current at the point where the device is installed. For circuit breakers as the **Record Plus™** this value is called the interruption or breaking capacity (I_{cu} or I_{cs}), a value dependent not only on the prospective fault current value but also on the system voltage rating. For DC networks the situation is basically the same as for AC networks.

However, the system voltage generally plays a greater role (is more difficult to interrupt) while the network defines how many poles need to participate in the interruption.

The drawing below indicates the three possible DC networks with the "worst" short-circuit for each of them, the number of poles that must participate in the breaking operation and the voltage level that needs to be interrupted.

Use in DC networks

Network Type	Center point connected to earth (A)	One pole connected to earth (B)	Insulated from earth (C) ⁽¹⁾
Electrical schemes			
Maximum short-circuit current (I_{cc} max)	short-circuit A-B	short-circuit A-B or A-C	short-circuit A-B
Minimum poles needed	2 (one on each polarity)	1 (unearthed polarity)	2 (one on each pole)
Breaking capacity on each pole	I_{cc} max at $V/2$	I_{cc} max at V	I_{cc} max at V

(1) When a pole is grounded due to a first fault nothing happens, on a second fault the network behaves like a system with "one polarity connected to ground"

Record Plus™ FD, FE, FG and FK line breakers can be used in DC networks with standard thermal magnetic trip units.

For **Record Plus™** FG line breakers, please contact us. The nominal current rating of the device does not vary in AC or DC applications. The setting of the short-circuit or magnetic device needs to be multiplied by 1.2 to determine its threshold in a DC network.

The table indicates the nominal current, the breaking capacity ($I_{cu}=I_{cs}$) and the number of poles needed to participate in the interruption.

Example

Rated voltage 500 V DC; Rated current 200 A I_{cc} max 50 kA

network A : center point connected to ground

FE250N 3x 250 - 1pole for each polarity

network B : one pole connected to ground

FE250N 3x 250 - 2poles on unearthed polarity.

network C : insulated network

FE250N 3 x 250 - 1 pole on each polarity

Use in DC networks with standard thermal magnetic trip units

Breaker	Rated current	110 V DC	250 V DC	440 V DC	500 V DC	Thermal threshold	Magnetic threshold
FD 63S	16÷63	25 (1p)	25 (1p)	25 (2p)	-	= AC	1.2
FD 63N	16÷63	40 (1p)	40 (1p)	40 (2p)	40 (2p)	= AC	1.2
FD 63H	16÷63	65 (1p)	65 (1p)	65 (2p)	65 (3p)	= AC	1.2
FD 63L	16÷63	100 (1p)	100 (1p)	100 (3p)	100 (3p)	= AC	1.2
FD160S	64÷160	25 (1p)	25 (1p)	25 (3p)	-	= AC	1.2
FD160N	64÷640	40 (1p)	40 (1p)	40 (2p)	40 (2p)	= AC	1.2
FD160H	64÷640	65 (1p)	65 (1p)	65 (2p)	65 (3p)	= AC	1.2
FD160L	64÷640	100 (1p)	100 (1p)	100 (3p)	100 (3p)	= AC	1.2
FE160N	25÷160	50 (1p)	50 (1p)	50 (2p)	50 (2p)	= AC	1.2
FE160H	25÷160	85 (1p)	85 (1p)	85 (2p)	85 (3p)	= AC	1.2
FE160L	25÷160	100 (1p)	100 (1p)	100 (3p)	100 (3p)	= AC	1.2
FE250V	125÷250	25 (1p)	25 (1p)	25 (2p)	-	= AC	1.2
FE250N	125÷250	50 (1p)	50 (1p)	50 (2p)	50 (2p)	= AC	1.2
FE250H	125÷250	85 (1p)	85 (1p)	85 (2p)	85 (3p)	= AC	1.2
FE250L	125÷250	100 (1p)	100 (1p)	100 (3p)	100 (3p)	= AC	1.2
FG400N							
FG400H							
FG400L							
FK800N	500÷800	50 (1p)	50 (2p)	36 (3p)	36 (3p)	= AC	1.2
FK800H	500÷800	60 (1p)	60 (2p)	60 (3p)	60 (3p)	= AC	1.2
FK800L	500÷800	80 (1p)	80 (2p)	80 (3p)	80 (3p)	= AC	1.2
FK1250N	640÷1250	50 (1p)	50 (2p)	36 (3p)	36 (3p)	= AC	1.2
FK1250N	640÷1250	60 (1p)	60 (2p)	60 (3p)	60 (3p)	= AC	1.2
FK1250L	640÷1250	80 (1p)	80 (2p)	80 (3p)	80 (3p)	= AC	1.2

Use at frequencies other than 50/60 cycles

Performance characteristics of protective devices used in electrical distribution networks or systems vary according to the network's rated frequency.

The **Record Plus™** family of circuit breakers is designed to offer their best performance at 50/60 Hz network.

The breakers can be used at 16 2/3 (applications in rail transport) and 400Hz (aviation) if the following is taken into account:

a) The rated breaking capacity is decreased ⁽¹⁾

b) The device trip unit settings are modified

Here the correct setting of the trip unit is vital to ensure that the circuit breaker performs well in the electrical distribution network.

Thermal magnetic trip units

Record Plus™ breakers and their trip units can be used at 16 2/3 Hz and 400 Hz provided that the trip units are set accordingly. The table indicates the coefficients to be applied for 16 2/3 Hz and 400 Hz applications.

Kt (for thermal)

Km (for magnetic)

The current values for each environment can be calculated by multiplying the values set on the breaker by the coefficients mentioned in the tables.

Electronic (SMR1) trip units

The breakers and their trip units can be used at 400 Hz (aircraft) provided that the trip units are set accordingly.

The table indicates the coefficients to be applied for 16 2/3 Hz and 400 Hz applications.

Kt (for LT)

Km (for ST)

The current values for each environment can be calculated by multiplying the values set on the breaker by the coefficients mentioned in the tables.

Use in networks with a frequency of 16 2/3 and 400 cycles

Breaker	Rated current	Trip Unit type	Thermal or LT settings		Magnetic or ST settings	
			Kt ₁₆ (16 2/3Hz)	Kt ₄₀₀ (400 Hz)	Km ₁₆ (16 2/3Hz)	Km ₄₀₀ (400 Hz)
FD63N, H or L	8÷63	LTMD, GTM or MO	1	0.95	0.8	1.6
FD160N, H or L	64÷160	LTMD, GTM or MO	1	0.9	0.8	1.6
FE160N, H or L	8÷63	LTM, LTMD, GTM or MO	1	0.95	0.8	1.6
FE160N, H or L	64÷160	LTM, LTMD, GTM or MO	1	0.9	0.8	1.6
FE250N, H or L	80÷250	LTMD, GTM or MO	1	0.9	0.8	1.6
FE160N, H or L	10÷125	SMR1	1	1	1	1
FE160N, H or L	160	SMR1	1	0.9	1	1
FE250N, H or L	40÷125	SMR1	1	1	1	1
FE250N, H or L	64÷250	SMR1	1	0.9	1	1
FG400N, H or L	100÷400	SMR1	1	0.8	1	1
FG630N, H or L	160÷630	SMR1	1	0.8	1	1
FK800N, H or L	320÷800	LTM	1	0.6	1	1
FK1250N, H or L	400÷1250	LTM	1	0.6	1	1

Example

A FE160N with LTMD 160A trip unit in a 400 Hz network:

(from the table Kt₄₀₀ = 0.9 / Km₄₀₀ = 1.6)

If Ir is set at 160A and Im set at 1200A the real

thermal threshold is $160 \times 0.9 = 144A$ at 40°

Thus the current in the circuit may not exceed this value

$I_m = 1200 \geq$

the real magnetic threshold is $1120 \times 1.6 = 1920A$

(1) Please consult us.

GE Consumer & Industrial Power Protection

The Power Protection division of GE Consumer & Industrial is a first class European supplier of low-voltage products including wiring devices, residential and industrial electrical distribution components, automation products, enclosures and switchboards. Demand for the company's products comes from wholesalers, installers, panel-board builders, contractors, OEMs and utilities worldwide



GE imagination at work

For more information, please contact:
MAJESTIC GLOBAL LTD. www.mgl.hk